

**SUPPLY, INSTALLATION, TESTING &
COMMISSIONING OF HVAC SYSTEM FOR SSGC
HEAD OFFICE BUILDING**

(TENDER IS ON COMPLETE PACKAGE BASIS)

(PEC CERTIFICATE IN CATEGORY C-4 OR ABOVE WITH SPECIALIZATION CODE IN ME01)

(HVAC OEM CERTIFIED / AUTHORIZED LOCAL RESOURCE FOR INSTALLATION, COMMISSIONING, OPERATION & MAINTENANCE SERVICES (ANY REPUTABLE CHILLERS MANUFACTURER))

(UNDER SINGLE STAGE TWO ENVELOPE BIDDING PROCEDURE)

AS PER PPRA RULES 2004.

**TENDER ENQUIRY NO:
SSGC/LP/EPADS/PT/2157168**

Bid Closing date & time: 16-06-2026 at 1030 hrs

Bid Opening date & time: 16-06-2026 at 1100 hrs

Supplier must be active in FBR Active Tax Payer List (ATL)
Sealed quotation of above referred requirement to be submitted in PKR

Venue:

Tender Room, CRD Building, Ground Floor
SSGC Head office complex Karachi -75300

Ph. +92-21-99021024,+92-21-99021173,+92-21-99021116.

Earnest Money (Fixed Bid Bond): PKR 500,000/-

"Note: Tender document is also available online on SSGC website for view only. Bidder is eligible to participate in bidding process only after purchasing the tender documents from Tender Room SSGC Head Office as per the procedure mentioned in the Press Publication / SSGC website. It is mandatory for bidders to attach original Token Slip in front of the Sealed Envelope (issued at the time of Purchasing) as an evidence that supplier has purchased the Tender documents. Further, any Corrigendum/Clarifications/Addendums/Extensions issued to be notified to only those bidders who have purchased Tender documents." (Not applicable on EPADS Tender).

Sui Southern Gas Company Limited

Procurement Department

ST-4/B, Block-14, Sir Shah Suleman Road, Gulshan-e-Iqbal, Karachi-Pakistan

Phone: +92-21-9902-1279, 1259

Fax: +92-21-99231583

www.ssgc.com.pk/ssgc

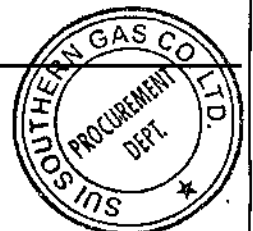

Checklist for Bidders

Enquiry #: _____

Opening Date: _____

Time: _____

M/s, _____

Please ensure before submitting the bid, that following information/ Documents have been submitted / providing along the bid. Kindly Check () appropriate box.

Sr. No.	Checklist Item	Action Required	Yes/No
1	Tender Document Availability on SSGC website & EPADS	Ensure the bidder participates via EPADS.	
		Download the tender document from EPADS.	
		Fill the BOQ/ Bid Form/ Schedule of Requirement correctly.	
		Submit the bid on EPADS before the deadline; otherwise, bid will be rejected.	
2	Physical Bid Bond Submission	Submit the physical bid bond to the Tender Room (SSGC HO) before the bid submission. And upload Scanned copy of Bid bond on EPADS.	
		If Bid Bond in original not submitted, the bid will be rejected.	
3	Bid Submission Deadline	Confirm all documents (electronic and bid bond in original) are submitted before the specified bid submission deadline.	
4	Signature and Stamp	Ensure all documents are signed and stamped as required and uploaded on EPADS or else bid will be rejected	
5	Additional Documents (if any)	Verify if any other documents specified in Tender document are included in the bid on EPADS	
6	Tender Fees	Rs. 0 (Free)	
7	Technical literature	Original Technical literature is enclosed, if any duly signed & stamped	
8	Any change in your current address, Phone Fax no & Email etc. intimated	Bidders are required to intimate Procurement dept. for any change in Current address, email, contact information etc. in tender documents	
9	Bid validity	Bid Validity as specified is mentioned	
10	Delivery / Completion period	Delivery / Completion period has been specified as per tender terms	
11	Corrections/Cutting/Overwriting	All corrections/cutting/overwriting are signed & stamped	
12	Sample	Sample (if necessary) is enclosed as per form attached in Tender Document	
13	Form-X	Form- X Duly Signed & Stamped	

Note:

Non-Availability of the above information/documents, or incomplete/incorrect statement on this checklist may result in rejection of the bid at / after the bid opening.

As per SRO296(1)/2023 dated 08th March 2023 "E-Pak Procurement Regulations, 2023" all bidders are advised to register in e-Pak Acquisition and Disposal System (EPADS).

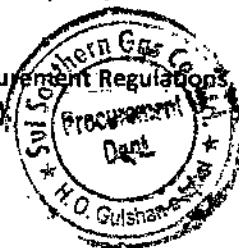

Bidders Authorized Representative

SSGC

SUI SOUTHERN GAS COMPANY LIMITED
Procurement/Department

M/A _____

Tender Enquiry No. _____

INVITATION TO BID

Sui Southern Gas Company Limited, (SSGCL) has pleasure in extending you an invitation, to submit bid for the subject material according to Terms and Conditions specified in the attached Tender Document. Please read following instructions before submission of bid:

1. Bids are to be submitted in sealed envelope provided with the tender, indicating Tender Enquiry Number & its opening date and time on the face of the envelope.
2. Bid Bond @ 2% of the total PQB / FOB value shall be enclosed with the bid without which bid will be rejected and returned to bidder unopened. The Bid Bond shall remain valid till the last date of the month in which it is expiring.
3. In case the bid opening date falls on a holiday or due to some unavoidable circumstances, it is not possible to open on scheduled date, it will be opened on next working day at the same time and at the same venue.
4. The bidder shall bear all expenses associated with the preparation and delivery of its bid/envelope and the Company will in no case be liable in this respect.
5. Prospective bidder requiring any information or clarification of the tender may notify the same by fax or at the mailing address. The Company will respond to any request for explanation or clarification, if received within reasonable time prior to submission of bids.
6. The Company reserves the right to cancel, add, delete or amend tenders/terms/conditions/any part of the tender during the bidding period without assigning any reason. However, bidders shall be informed about it prior to bid opening process.
7. The Company reserves the right to accept or reject any bid or part of a bid or to amend the bidding process and reject all bids at any time prior to award of contract/purchase order without thereby incurring any liability to the affected bidder(s).
8. In case of Single stage two (02) envelope bidding procedure (if mentioned in press advertisement & Tender documents), sealed technical offer & sealed bid shall be submitted in separate envelopes. Bid Bond will be enclosed with "commercial" bid. "Technical Proposal" and "Financial Proposal" is to be mentioned on the top of the envelope. Technical offers will be opened and evaluated first. Financial offers of only technically compliant bidder will be opened at a later intimated date in presence of bidder's representatives. Financial proposal of technically non-compliant bidders will be returned unopened along with their bid bond.
9. For Tenders invited on P.Q.B/C&F basis, conditions as mentioned in Section-1A will also apply.
10. The Company will appreciate confirmation by fax No 92-21-99231533 or email at smmt@ssgc.com.pk or to DGM (Procurement) of your intention to submit the bid and if not interested in submission of bid, it will be appreciated if it is intimated through fax or email with mentioning of reasons.
11. Bids are required to be submitted at:

Tender Room, CRD Building, Head Office Complex, Sir Khush Bakht Road Gulshan-e-Iqbal, Karachi
Pakistan. Ph. 0092-21-99021024, 0092-21-99021223, 0092-21-99021279, 0092-21-99013074,
Fax # 0092-21-99231533, Email smmt@ssgc.com.pk

Hope and look forward for your valued participation.

Thanking you

Yours sincerely,

General Manager (Procurement)

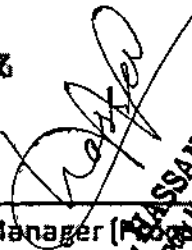
HASSAN ANSARI
General Manager (Procurement)
Sui Southern Gas Co. Ltd.



General Terms & Conditions

1. Submission of bids:

- 1.1. Bids are to be submitted in sealed envelope provided with the tender (in such a manner that contents are fully kept enclosed and cannot be seen until opened) indicating tender enquiry number, its opening date and time on the top of the envelope. Envelopes shall be addressed to General Manager (Procurement Department) on the address provided on "invitation to bid". Envelope shall indicate the name and address of the bidder for returning the bid in case it is declared late or submitted without bid bond.
- 1.2. Sealed bids (as above) shall be mailed/submitted/dropped in tender box placed at Tender Room, CRD Building, SSGC Head Office. Bids are to be delivered on or before closing time after which bid will not be entertained. In case bid is sent through courier, the same shall be delivered at least half an hour before scheduled opening time.
- 1.3. The Company may at its discretion extend the closing date for the submission of bids, in which case all rights and obligations of the purchaser and bidders previously subject to the closing date will thereafter be subject to the date extended. However, any request for extension received from prospective bidders less than one week prior to bid opening date may not be entertained. In case of extension in bid opening date, the same will be advertised in press and simultaneously shall be intimated to prospective bidder who had purchased the tender documents.
- 1.4. The bid shall contain no interlineations, erasures or overwriting except as necessary to correct the errors made by the bidder, in case of any correction etc. it shall be signed and stamped by the person signing the bid.
- 1.5. The quoted price shall be inclusive of all duties/taxes except GST, which is to be mentioned separately. The supplier shall declare (if applicable) regarding non-applicability of GST for which documentary evidence shall be enclosed or could be produced upon demand.
- 1.6. Rates shall be item-wise, as given in price schedule/schedule of requirement/Bid Form unless otherwise specified.
- 1.7. Bidder is responsible for timely delivery of bids at location specified 1.2 above. Company will not be responsible for misplacement/ tampering/non-attendance/delay or any other incident in case the bid is not delivered at the designated place & time.
- 1.8. Any bid received late after the closing date and time, will be rejected and returned unopened.
- 1.9. The quotation shall only be acceptable on/as per Bid Form. In case for foreign tender when Local Agent submits bid on behalf of different bidders, a separate Bid Bond for each Bid is required. Likewise for tender when bidder submit alternative bids a separate bid bond for each bid is required or else bid will be liable for rejection.
- 1.10. Deviation from tender terms and conditions is not allowed. However, in unavoidable circumstances, these shall be mentioned at the bottom of "Section 3: Bid Form" deviation on any other page will not be entertained.
- 1.11. Discount offered (if any) shall be mentioned on the "bid form" only.
- 1.12. The bidder(s) or their authorized representative shall put his full signature with stamp & date on each page of tender document as well as enclosure vis-a-vis drawings, specifications etc. Any correction, overwriting shall be duly signed & stamped.
- 1.13. The bid is to be completed and returned to the Company in accordance with General terms & conditions. General terms & conditions duly signed & stamped (as a token of acceptance) shall be submitted along with Bid Form (Price schedule) duly completed as per requirement. However, specifications/drawing is to be retained by bidder for their future references.

2. Eligible Countries / bidders:

The invitation for bids is open to all manufacturers/suppliers/stockiest/dealers/pre-qualified bidders but is not applicable to those countries where inter trade protocols with Pakistan do not exist or those countries from where imports are not allowed by Government of Pakistan.

3. Qualification/Disqualification of Suppliers:

The Company, at any stage ~~may~~ **shall follow the Attached Black Listing Mechanism**, having credible reasons for or prima facie evidence of any defect in suppliers/contractors, may require the suppliers or contractors to provide information regarding their professional, technical, financial, legal or managerial competence.

**Please Follow the Attached
Black Listing Mechanism**

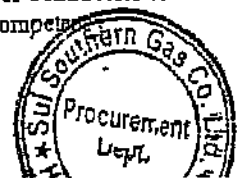

whether already pre-qualified or ~~Company shall~~ **Follow the Attached** ~~Company shall~~ unqualify a supplier or contractor if it finds, at any time that the information regarding ~~existing~~ **existing** ~~supplier or contractor~~ **Mechanism** was false and materially inaccurate or incomplete.

4. **Joint Ventures:**

In the event that the successful bidder is a joint venture (formation of two or more companies), the Company will require an undertaking on judicial stamp paper that the parties to the joint venture accept joint and several liabilities for all obligations under the purchase order/contract.

5. **Clarification of tender documents:**

Prospective bidders requiring any further information or clarification of the tender documents may notify the Company in writing or by fax or at the Company's mailing address indicated in the "invitation to bids". The Company will respond in writing to any request for information or clarification of the tender documents, if received five working days prior to closing date for the submission of bids prescribed by the Company. The Company response (including an explanation of the query) will be sent in writing or by fax/e-mail to all prospective bidders who have purchased the tender documents. Verbal instructions/reference will not be acceptable.

6. **Modification and withdrawal of bid:**

- 6.1 The bidder may modify or withdraw its bid after the bid submission, provided the written notice of the modification or withdrawal is received by the Company prior to the deadline prescribed for submission of bid. After the bids/quotations are opened, no bidder shall be allowed to revise, propose or request any change in the bid.
- 6.2 The bidder's modification or withdrawal notice shall be sealed and addressed to GM (P). A withdrawal notice may be sent by fax followed by a signed copy.
- 6.3 Bids once opened cannot be withdrawn during validity period.

7. **Bid validity:**

All offers shall remain valid up to 90 days (120 days in case of Two Envelope bidding procedure) from the date of opening of bids, until any further extension agreed by the bidder. If the bidder agrees for extending bid validity the bid bond shall also be extended accordingly. A bidder giving extension to his bid validity will not be required or permitted to modify his bid. If there will be any query/clarification or extension request asked by the Company, the bidder should reply the same within 7 days after receipt of the same and if bidder takes more than 7 days the delay in reply will be added to their bid validity period.

8. **Rate Escalation:**

8.1 **All items except line-pipe:**

Quoted prices shall remain valid, firm, irrevocable and fixed till the fulfillment of obligations by the bidder and will not be subject to escalation / change on any account.

8.2 **Line-pipe only:**

8.2.1 Bidders are essentially required to submit detailed breakdown of rates indicating per ton price of:

a) H.R. Coil.

b) All other charges (including wastage, transportation, conversion cost etc).

8.2.2 Rate / price offered by the bidders shall be firm and irrevocable. However bidder offering pipe manufactured from Pakistan Steel Mills (PSM) HR coil are required to submit certified documentary evidence of HR coil rates. Adjustment in line-pipe rates (from the bid opening date till the currency of order) due to change in rate of HR coil manufactured by PSM is admissible to the extent of raw material cost without wastage. The bidders are required to submit certified documentary evidence of HR coil rates published by PSM, at the time of submission of bids. SSGC may verify the document / rates from PSM.

8.2.3 The variation clause however shall not be applicable on line-pipe quantities which were delivered within 20 days of the announcement of the variation (both days inclusive) in price of HR coil by PSM.

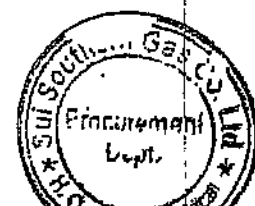

8.2.4 The variation clause also shall not be applicable on the line pipe quantities delivered after the specified delivery schedule (total or monthly consignment wise)

8.2.5 No escalation is applicable on line pipe manufactured from imported ER coil.

9. **Bid bond (earnest money):**

Bid bond equivalent to two percent (2%) of the total offer value, in favor of Sui Southern Gas Company Ltd. shall accompany the bid if bid value is above Rs. 500,000 in the form of pay order, demand draft, call deposit receipt or a bank guarantee (specimen of bank guarantee is attached at Annexure-A), issued by a scheduled bank in Pakistan. The bid bond shall remain valid for 120 days (150 days in case of Two Envelope bidding procedure) unless specified otherwise. The bid bond shall be returned/refunded to the unsuccessful bidders while the bid bond of the successful bidder shall be retained, till submission of Performance bond (if applicable). Bids without bid bond will not be considered. In case the order value is less than Rs: 500,000 the bid bond in lieu of performance bond will be retained till fulfillment of obligations by the supplier. However, in either case the bidder is responsible to arrange the extension the bid bond validity as per requirement. If bid bond submitted by the supplier is more than 2% of ordered value, it may be replaced with appropriate value. If order value is less than Rs. 500,000, the bid bond will be returned along with the order. Bid bonds of non-compliant bidders may be released during evaluation process. The bid bond may be forfeited if a bidder withdraws the bid during validity period specified by the bidder or if successful bidder fails to:

- > Accept purchase order,
- > Furnish performance guarantee in accordance with clause 16 of Section 1,
- > Supply material as per requirement and delivery schedule.

9.1 In the event of bid bond validity following short of the prescribed period of 120 or 150 days as the case may be either (i) due to extension in the bid submission date or (ii) where so required by the procuring agency, then in such an event it shall be mandatory on the bidder to extend the bid bond validity upto 120/150 days within 30 days of the opening of technical proposal / bid, and / or where so required by the procuring agency.

9.2 In the event of the bid security amount deposited / furnished by the bidder falls short by 10% of the requisite Bid security amount. The procuring agency keeping in view the nature of the procurement may consider and allow the bidder to deposit / furnish the balance 10% amount, provided the bidder does so within 15 days of the opening of the bid. Notwithstanding that all other terms & conditions have been fully complied with.

10. **Opening of bids:**

Bids will be opened in presence of bidders or their authorized agents at the address provided on "invitation to bids". The bidder's representatives who are present shall sign the bid opening sheet (attendance sheet) to mark their attendance/witness. Commercial contents of bids will be announced/recorded in bid opening sheet.

11. **Preliminary Examination of bids:**

11.1 The Company will examine the bids to determine their completion, computational errors, provision of guarantees, authorized signature and other related matters.

11.2 Arithmetic errors will be rectified on the following basis: Discrepancy between unit price and the total price obtained by multiplying the unit price and quantity, the unit price shall prevail and the total price will be corrected. Discrepancy between total bid amount and the sum of total prices, the total prices shall prevail and the total bid amount will be corrected.

11.3 Prior to a composed evaluation, the Company will determine the substantial responsiveness of each bid to the bidding documents. In Company's opinion a substantially responsive bid is the one which conforms to all the terms and conditions of the bidding documents without any material deviation.

11.4 Bid determined as not substantially responsive will be rejected by the Company and cannot subsequently be made responsive by the bidder through correction of the non-conformity.



12. Clarification of submitted bids:

To assist in the examination, evaluation and comparison of bids, the Company may at its discretion inquire any clarification from bidder about their bid. All responses by bidders shall be provided in writing and no change in the price or substance of the bid shall be sought, offered or permitted.

13. Technical Literature & Samples:

The Bidder(s) shall submit the following:

- 13.1 Samples (if applicable/required)
- 13.2 Original or legible copy of technical literature/performance characteristics
- 13.3 Test Certificates (if applicable/required)
- 13.4 Documentary evidence for legal import in case of imported material. (At the time of delivery when quoted on FOR basis)
- 13.5 In case of pipeline operation material bidders must also attach a "proof from supplier/ manufacturer, that goods offered have been used successfully on a high pressure natural gas pipeline elsewhere under tropical climatic conditions.

13.6 Specification Compliance Sheet:

Company requires a clause-by-clause commentary on the Specifications, demonstrating the materials responsiveness to those specifications or a statement of deviations and exceptions to the provisions of the specifications, if so required/desired. For purposes of the commentary to be furnished pursuant to above, the bidder shall note that standards for workmanship, material and equipment and references to brand names or catalogue numbers, designated by the Company in the specifications are intended to be descriptive only and not restrictive. The bidder may substitute other authoritative standards, brand names and/or catalogue numbers in its bid provided which demonstrates to the Company's satisfaction that the substitutes are equivalent or superior to those designated in the specifications by the Company.

Bid which does not possess above documents, certificates etc., may be considered technically Non-compliant.

- 13.7 The offer shall be accompanied with all technical data/documents/certifications as required under the tender specifications. Evaluation shall be carried out on the basis of data/ documents/certifications submitted with the bid. No clarification, additional information may be sought / accepted after bid opening.

13.8 Deviation to technical specifications:

The bidder shall fill the "technical compliance sheet" and mention offered specifications along with reference to its technical brochure/literature (page/clause No.etc). Statement such as "Compliant" or "Confirmed" is not acceptable. Deviation to tender terms and technical specification is not acceptable. However, if bidder feels to mention minor deviation, the same shall be referred categorically on the "Bid Form" as well as on the technical compliance sheet stating reference of its technical data sheet/brochure. In case of insufficient information, data or documents, the Company is not liable to seek clarification and the bid may be determined non-compliant on provided information.

14. Award/Evaluation Criteria:

- 14.1 In case of locally manufactured items e.g. service line material & meter components, manufactured by local vendors, the lowest bidder will be awarded maximum quantity as per his declared capacity and past performance in respect of delivery and quality. New vendors / manufacturers shall also be considered for placement of a purchase order up to a maximum of 10% of the tender quantity if their submitted sample has been tested and approved and provided they have quoted lowest price or agree to accept the order on lowest received price.
- 14.2 Generally for other items other than above, ordering shall be based on technical compliance and lowest quoted price. Supplies may be subject to pre shipment inspection and post qualification by a third party in case of foreign material. If required during the process of manufacturing and / or inspection, SSGCL representative may visit the manufacturer facility to witness the manufacturing / inspection process.

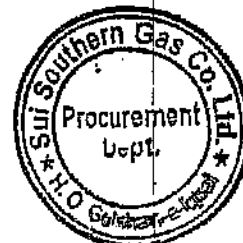

- 14.3 Evaluation may be carried out both on item or on group of items/single or multiple package basis depending upon the nature of requirement exclusively at the discretion of the company to ensure economic procurement.
- 14.4 Company reserve the right to settle the final terms of supply with the lowest evaluated and commercially responsive bidder. Any effort by the bidder (s) to influence the outcome of bid evaluation or placement of purchase order may result in disqualification of the bidder.

15. Loading of Bids:

Bids may be loaded with following if offer found to be deviated from specifications, delivery schedule, terms & conditions without stating the amount involved in such deviation by following method:

- 15.1 The cost of compensation /loading amount for that item shall be derived from the bid itself.
- 15.2 If 15.1 is not possible, average of rates of other bidders, who have quoted for that item conforming to technical specification, shall form the basis for cost compensation/loading.
- 15.3 The company will encourage participation by local bidders who will be given price preference. Landed cost factor shall be determined as per prevailing Government policy / SRO. However they will submit details of local value addition on raw material imported by them and percentage of locally manufactured component with documentary evidence.

16. Performance Bond:

- 16.1 In case purchase order value is above Rs:500,000, the successful bidders shall submit performance bond guarantee which is to be submitted within ten days from receipt of LOI or order along with integrity pact. The successful bidders shall submit a performance bank guarantee (PBG) in the form of a pay order or bank guarantee (specimen attached at Annexure-B) issued by a scheduled bank in Pakistan, for an amount equivalent to 10% of the total value of the purchase order or as specified, in the "letter of intent". The performance bond unless specified otherwise; shall remain valid till:
- 16.1.1 Completion of final satisfactory delivery in case of consumable items.
- 16.1.2 12-18 months from the date of satisfactory delivery of the equipment/machinery.
- 16.1.3 Satisfactory delivery/installation of system in case the installation responsibility is on supplier's part.
- 16.1.4 120 days in case of chemicals.
- 16.1.5 In case of locally manufacturing item, the PBG equivalent to 3 months delivery schedule will be required after placement of purchase order which should remain valid till completion of final satisfactory delivery of the ordered quantity.
- 16.1.6 In case of small diameter line pipe (MS/MDPE) the PBG shall remain valid up to 3 months after completion of satisfactory final delivery.
- 16.1.7 In case of Vehicles, Manufacturer's Warranty is required in lieu of PBG.
- 16.2 The guarantee will be released after completion of this period, subject to satisfactory performance of the supplied equipment/machinery/system as mentioned at 16.1 above. The supplier shall keep the guarantee valid at their cost until fulfillment of the obligations.
- 16.3 In case the bidder does not submit the performance bond as specified, the delivery time of goods shall be deemed to have commenced 10 days (15 days in case of import) from the issuance of letter of intent/purchase order. The proceeds of the performance bond shall be payable to the Company as compensation for any loss resulting from the supplier's failure to complete its work under the purchase order/ contract. The validity period of the performance bond is to be extended if the delivery date/period is being extended mutually by the Company/Supplier.
- 16.4 The performance bond will be discharged / returned by the Company not later than thirty (30) days following the date of completion of the supplier's work under the purchase order/contract including any warranty/guarantee/performance obligations as specified in the special conditions of contract. The supplier shall not be absolved of their liability to perform in case of encashment of performance bond by the Company, who shall have the right to claim and receive all damages/losses incurred due to non-performance.
- 16.5 The Company shall promptly notify the supplier in writing for any claim arising under this guarantee. Upon receipt of such notice, the supplier shall promptly repair or replace the defective goods or parts thereof, without cost to the Company other than, where applicable the cost of inland delivery of the repaired or replaced goods or parts from the port of entry to the final destination.

16.6 If the supplier, having been notified, fails to rectify the defect (s) in accordance with the purchase order/contract, the Company may proceed to take such remedial actions as may be necessary at the supplier's expense. Any amount payable by the supplier under this clause may be recovered by the Company, by withdrawing from the performance bond without having to notify or seek the approval of the supplier.

16.7 The provisions herein contained shall be construed to limit supplier's obligation of performance of the order/contract to the value of the performance bond.

16.8 **Guarantee/Warranty:** In case where performance guarantee is not applicable, the supplier shall confirm that all supplied goods under the contract/purchase order are new, unused, of the most recent or current models and incorporate all recent improvements in design and goods unless provided otherwise in the contract/purchase order. This guarantee shall remain valid for a period of twelve to eighteen months after the goods have been delivered or commissioned.

17. Purchase Order/Contract:

Purchase order of quoted material may be placed on fulfillment of conditions mentioned at 14 & 16 above which is through formal confirmation for proceedings with the suppliers.

18. Assurance:

The successful bidder will be required to give satisfactory assurance of its ability and intention to deliver the goods, pursuant to the tender enquiry and contract within the time set forth therein.

19. Force Majeure:

19.1 In the event of either party hereto being rendered unable, wholly or partially, by force majeure circumstances to carry out its obligations under the purchase order/contract documents, such party shall give notice and full particulars and other satisfactory evidence of such force majeure circumstance(s) in writing or by fax to the other party within 7 days after the occurrence of the cause(s). Relieved upon the obligations of the party giving such notice so far as they are affected by such force majeure shall be suspended for the period during cause(s) shall, as far as possible, be remedied and obviated with all reasonable dispatch. The term 'force majeure' as employed herein, shall mean acts of God or public enemy, civil insurrection, fires, floods, earthquakes or other physical disasters, order or request of governments, blockade or embargo. It is, however, clarified that strikes, lockouts, shortage or non-availability of raw materials, rains, and disturbances, other labor dispute or congestion's in ports on the supplier's side shall not be included in the term 'force majeure'.

19.2 In case the force majeure contingencies last continuously for more than one month, both parties will agree on the necessary arrangements for the further implementation of the purchase order/contract. In case further implementation is unforeseeable and impossible, both parties shall arrange for the termination of the purchase order/contract, but without prejudice to their rights and obligations prior to such termination it being understood that each party shall fulfill its contractual obligations so far as they have fallen due before the operation of force majeure.

20. Amendment in purchase order/contract:

20.1 The Company may at any time by a written notice to the supplier make changes within the general scope of the purchase order/contract in any one or more of the following:-

20.1.1 Drawings, designs or specifications where goods to be furnished under the purchase order/contract are to be specifically manufactured for the Company.

20.1.2 The method of shipment or packing.

20.1.3 The place of delivery.

20.1.4 Quantities of item up to a maximum variance of +15% of purchase order/contract value.

20.2 Company reserves the right to increase/decrease the quantities or delete any or all items listed in the price schedule/schedule of requirement/bid form without assigning any reason.

20.3 Upon notification by the Company of such modifications the supplier shall submit to the Company an estimated cost for the proposed modification within ten (10) calendar days of receipt of notice of the modification and shall include an estimate of the impact (if any) of the modification on the delivery dates under the purchase order/contract, as well as a detailed schedule for the completion of the modification, if applicable.

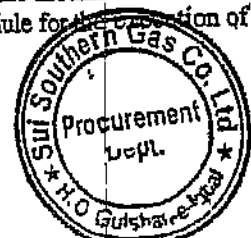

SSGC

- 20.4 The supplier shall not perform modification in accordance with clause 20.1 above until the Company have authorized a modification order in writing on the basis of the estimate provided by the supplier as described in clause 20.3.
- 20.5 Modification mutually agreed upon shall constitute a part of the work under the purchase order/contract and the provisions and conditions of the contract shall apply to the said modification.
- 20.6 If modification made by the Company results in a variation in purchase order/contract quantities whose net cost effect is within 15% of the total value then the original purchase order/contract rates would be applicable. Any "modification" affecting the quantities and the corresponding cost effect beyond 15 percent would be mutually agreed upon between the Company and the supplier.

21. Extension in delivery period:

- 21.1 Delivery of the goods shall be made by the supplier in accordance with the schedule of requirement and delivery period; however, the supplier may claim extension of the time limits as set forth in the schedule of requirements and delivery period in case of
- 21.1.1 Modification in the goods ordered by the Company pursuant to clause 20.
- 21.1.2 Delay in provision of any services which are to be provided by the Company (services provided by the Company shall be interpreted to include all approvals by the Company under the contract).
- 21.1.3 Delay in performance of work caused by orders issued by the Company.
- 21.2 The supplier shall demonstrate to the Company's satisfaction that it has used its best endeavors to avoid or overcome such causes for delay and the parties will mutually agree upon remedies to mitigate or overcome such causes for delay.
- 21.3 Notwithstanding clause 21.1 above, the supplier shall not be entitled to an extension of time for completion unless the supplier at the time of such circumstances arising, immediately has notified the Company in writing of any delay that it may claim as caused by circumstances pursuant to clause 21.1 above and upon request of the Company, the supplier shall substantiate that the delay occurred is due to the circumstances referred by the supplier.

22. Packing:

- 22.1 The material shall be in original/sealed packing to ensure delivery without any damage during transit.
- 22.2 If any of the good is discovered to be damaged or unacceptable at the point of embarkation, the supplier shall be responsible for replacement of those goods free of any charge and cost to the Company, within the delivery time schedule of the contract/purchase order.
- 22.3 The identification marks showing contents, quantity and contract/purchase order number shall be printed on each skid/metal container/case containing one copy of invoice & packing list.
- 22.4 Handling and Transportation:
The Supplier shall arrange for the proper stacking of the Goods and for its proper storage and lashing and for other such provisions/suitable measures as may be necessary to safeguard against movement and damage to the Goods from the point of loading to its designated destination.

23. Inspection:

- 23.1 Pre-delivery inspection may be carried-out at the premises of supplier(s) and/or post delivery inspection at company's any location, by the appointed inspector/inspection team, third party inspectors appointed by the Company.
- 23.2 The Company reserves the right to arrange inspections and tests to the goods or manufacturing processes at any stage at any of the premises of the supplier or its subcontractor(s) or and at the point of delivery; and at the goods final destination. Where conducted on the premises of the supplier or its sub-contractor(s), all reasonable facilities and assistance including access to drawings and production data shall be furnished to the inspector at no charge to the Company. Such inspection, however, shall not relieve the Supplier to fulfill the obligations under the



purchase order/contract. If goods fail to conform to the specifications, the Company may reject them.

24. Delivery:

- 24.1 Free delivery at any of the following locations, unless specified otherwise:
- 24.1.1 R & D Section, Stores Department Abul Hasan Ispahani Road Karachi
 - 24.1.2 R & D Section, Stores Department F-37, SITE Karachi.
 - 24.1.3 R & D Section, Stores Department F-76, Dope Yard SITE, Karachi.
 - 24.1.4 Meter Manufacturing Plant, Sir Shah Sulaiman Road, Gulshan-e-Iqbal Karachi.
 - 24.1.5 Khadeji Store, 57th Kilometer at Super High way Karachi.
 - 24.1.6 Any other location specified by the company.
- 24.2 Delivery period shall commence after 10 days (15 days in case of import) of the issuance of letter of intent or from the date of purchase order/contract whichever is earlier, unless otherwise specified.
- 24.3 The supplier shall replace defective material at their risk & cost including transportation, duty, taxes etc.
- 24.4 GST Invoice if applicable be submitted at R&D section Stores Department along with material & delivery challan.
- 24.5 Unloading and stacking through cranes, fork lifters, labor etc. will be arranged by supplier at delivery site (for material like Pipes/Heavy Machinery & Equipment etc).
- 24.6 Delivery is to be made strictly in accordance with "delivery schedule" as specified by the Company.
- 24.7 The rejected material is to be collected/lifted by the supplier within a maximum period of one month after its intimation by the Company. Beyond specified period, the Company shall not be responsible for storage/safety of the uncollected material.

25. Delivery Failure:

- 25.1 In case the supplier fails to supply/ship the material within the stipulated period, the Company have the right to make an alternative arrangement for the purchase of the goods on such terms as may be offered. In such event all losses, cost and charges sustained/incurred by the Company on stated purchase shall be recovered from the Supplier without prejudice to any other right or remedy available to the Company which includes recovery of losses sustained by the Company from any due payment of the said supplier.
- 25.2 In the event Company remains unable to make such alternative arrangements, the Company has the right to recover from the supplier any or all losses sustained as a result of the supplier's failure to ship/supply the goods as per schedule of delivery.
- 25.3 In the event Company being forced to purchase any quantity or any other alternative not specified in this document as a result of any failure to supply/ship the material, the Company shall have the right to terminate the contract/purchase order without prejudice to any other rights or remedies available to the Company.

26. Payment:

- 26.1 The supplier after delivery of goods and its acceptance shall submit invoice to Finance Department of the Company, containing following information i.e.
- (a) Purchase order No. & date
 - (b) Items
 - (c) Quantity
 - (d) Price
 - (e) Invoice value
 - (f) Point of delivery
 - (g) Delivery challan indicating delivery date, etc.
- Payment will be made within 30 days of completion of stated formalities.

- 26.2 Income Tax @ 3.5% or as applicable under the prevailing government rules will be deducted at source (except where the supplier provides an income tax exemption certificate). Quoted price shall be inclusive of all taxes, except GST which shall be mentioned separately. Supplier(s) are required to submit signed and stamp acknowledgement slip, Sales Tax return, Annex "C" & Annex "I" (whichever applicable) in which Sales Tax (of relevant Sales Tax invoice) is

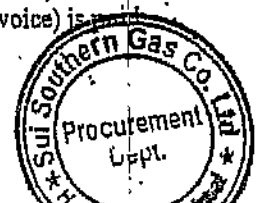

- 26.3 In case supplier is not liable to pay tax under the income tax ordinance or is liable to pay tax at a lower rate the supplier shall obtain a certificate from the tax authorities in Pakistan to that effect. In case the required certificate is not produced by the supplier prior to the date of payment, then the Company shall deduct tax at source from the gross payment payable to supplier.

27. Liquidated damages:

- 27.1 If supplier fails to deliver ordered material within the stipulated period/scheduled time specified in purchase order, Company, without prejudice to any other remedies, shall deduct from the bill or any other due payments/guarantees, as liquidated damages, a sum equivalent to 0.1% per day of the undelivered goods up to maximum 10%. The liquidated damages shall also be applicable for the cancelled quantity of goods under clause 28.
- 27.2 Whenever liquidated damages become payable, in the event that delivery of all goods and equipment is not made within the time period specified except on account of force majeure, the Company shall quantify the same and shall serve notice to the supplier requiring payment thereof. If the supplier fails to remit payment within 15 days of receipt of such notice, the Company shall forth-with become entitled to recover the same without recourse to the supplier, by calling upon The Performance Bond, withdrawals by way of liquidated damages shall not reduce the value of the Performance bond.
- 27.3 The payment of liquidated damages shall not relieve the supplier from performing and fulfilling all its obligations under the contract/purchase order nor shall the right and entitlements of the Company be affected or reduced in any manner.
- 27.4 In case of order placed on FOB/C&F basis, the delivery period shall commence from the date of confirmation of L/C. However, delayed submission of PBG period in excess of time limit will be deducted from the delivery period for the purpose of recovery of late delivery charges.
- 27.5 The liquidated damages shall be the sum equivalent to point one (0.1%) percent of the Contract price of the delayed goods as unperformed services for each day of delay, until actual delivery or performance, up to a maximum deduction of ten (10) percent of the Contract price. Once this maximum is reached, the Company may consider termination of the Contract at the risk and cost of the Supplier.

28. Default by Supplier:

- 28.1 The Company may, without prejudice to any other remedy by written "notice of default" sent to the supplier, cancel the purchase order whole or in part; if:
- 28.1.1 The supplier fails to deliver any or all of the ordered quantity as per specified delivery schedule or any extension thereof granted by the Company
- 28.1.2 The supplier fails to perform any other obligation(s) under the "purchase order".
- 28.1.3 The Company during the delivery period has reasons to believe that the supplier will not be able to fulfill the obligations under the purchase order/contract.
- The Company prior to exercising its right to cancel the purchase order/contract shall issue notice to the Supplier specifying the default(s) and the supplier shall submit an explanation within seven (07) days of receipt of such notice. If such explanation is not furnished within the stipulated time or if so furnished, is found to be unsatisfactory and/or the default(s) continues, purchase order/contract may be cancelled. The Company in addition to cancellation of purchase order/contract may suspend/cancel the enlistment of supplier.
- 28.2 The Company shall have the right to terminate/cancel the contract/purchase order concluded between the supplier and Company; if:
- 28.2.1 The successful bidder fails to furnish the performance bond as under clause 16 thereof.
- 28.2.2 The supplier fails otherwise to perform, fulfill or comply with terms, conditions, regulations and requirements of the contract/purchase order to carry out the work in accordance with the provisions thereof or abandons the shipment
- 28.2.3 The supplier becomes bankrupt or insolvent or makes an assignment for the benefit of its creditors.
- 28.2.4 One or more consignments of material delayed by a period of more than three months or non-supplied.
- 28.2.5 Rejection of manufacturing items as a result of observation by inspection team.

- 28.2.6 Penalty on higher rejection rate of supplied goods.
- 28.3 The supplier shall have the right to terminate the contract/purchase order if-
- 28.3.1 The Company fails to establish the "letter of credit" within the stipulated period as required.
- 28.3.2 The Company becomes bankrupt or insolvent or makes an assignment for the benefit of its creditors.
- 28.3.3 The Company is in default and breach of its obligation and liabilities under the contract/purchase order.
29. **Resolution of disputes:**
The Company and the supplier shall make every effort to resolve the disagreement or dispute arising between them amicably by direct discussion under or in connection with the purchase order/contract.
30. **Applicable law:**
The purchase order/contract shall be governed by and interpreted in accordance with the laws of the Islamic Republic of Pakistan.
31. **Declaration/Integrity Pact/Certification:**
- 31.1 Successful supplier shall furnish the declaration (specimen attached at Annexure-C) within 10 days after issuance of LOI/order /contract if the order/contract value becomes Rs:10 million or above.
- 31.2 In case of F.O.B/C&F Purchase order/Contract, the Principal as well as "local agent" both will sign the "integrity pact" as required under this clause.
- 31.3 Bidders to submit a certificate on Rs:100/- non-judicial stamp paper certifying that they are not black listed by the Government/Autonomous bodies and declared as defaulted supplier.
32. **Arbitration/resolution of disputes:**
- 32.1 Any difference or dispute arising out of or in connection with the contract between the Company and the supplier which can not be amicably resolved shall be referred to arbitration in Karachi, Pakistan, to two arbitrators, one appointed by each party of such difference/ dispute. In case the judgment of the said Arbitrator being at variance, the matter shall be referred to an "umpire", who shall be appointed by both the side Arbitrators. The umpire shall be retired judge of a High Court or the Supreme Court of Pakistan. Such arbitrators and umpire shall together proceed to adjudicate the disputes in accordance with the Arbitration Act, 1940, as amended from time to time.
- 32.2 Prior to exercising any right by the Company or supplier to terminate the purchase order/ contract under the conditions stipulated above, a return notice shall be required to be given to the other party specifying such default(s) and calling for submission of an explanation within seven (7) days of receipt of such notice. If such explanation is not furnished within the stipulated time or if so furnished, is found to be unsatisfactory, and the default(s) continuous, the purchase order/contract be terminated with notice to other party.
- 32.3 The agreement shall be governed by Law of Islamic Republic of Pakistan and the arbitration language shall be English.
- 32.4 During the course of arbitration, the supplier shall not suspend the performance of his responsibilities and obligations under the contract unless authorized by the Company in writing to do so.
- 32.5 In addition to the remedies as stated above, there is a "grievance committee" formed by the Company which can be approached by supplier in case of non-settlement of issues at any stage if supplier feels that settlement is not insight or not justified.
33. **Redressal of grievances by the procuring agency:-**
- 33.1 Grievance Committee is in place to address the complaints of bidders that may occur prior to entry into the procurement contract.
- 33.2 Aggrieved bidder may lodge a written complaint concerning his grievances not later than fifteen days after the announcement of the bid evaluation report.
- 33.3 Bidder is to submit complaint on letter head duly signed by the authorized person. Tender reference, details / nature of complaint, complainant active telephone, cell, postal address, email

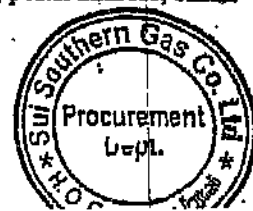

address must necessarily be provided. Incomplete / anonymous complaints will not be responded at all.

33.4 The Committee shall investigate and decide upon the complaint within fifteen days of the receipt of the complaint.

33.5 Mere fact of lodging of a complaint shall not warrant suspension of the procurement process.

34. **Blacklisting of Suppliers and Contractors:**

The Company shall permanently blacklist or temporarily debar (at least for 6-months from participating in SSGC's tender proceedings) if, a supplier or contractor who either constantly fails to perform satisfactorily performance or found to be indulged in corrupt and fraudulent practices as defined below:

34.1 Corrupt and fraudulent practices" includes the offering, giving, receiving, or soliciting of anything of value to influence the action of an official/Company.

34.2 If the supplier/contractor found responsible for the detriment of the Company during proceedings of procurement/contract, prior to its execution.

34.3 Misrepresentation of facts in order to influence the procurement process or the execution of the purchase order/contract.

34.4 Collusive practices among bidders (prior to or after bid submission) designed to establish bid prices at artificial, non- competitive levels and to deprive the Company of the benefits of free and open competition.

35. **Supplier's Guarantee and Responsibilities:**

The Bidder/Supplier shall guarantee that the materials supplied against this tender enquiry is new and is of acceptable quality and has been tried and approved on similar jobs. The validity and scope of such guarantee will be in accordance with conditions stated in this document. In case the opinion of the Company the Goods fail to perform the services in accordance with the specifications specified in Section IV due to manufacturing defects/defective material and/or workmanship, the Supplier shall replace, repair or reconstruct such Goods at his own cost in Pakistan wherever the Goods shall be located so that such Goods shall be restored to such conditions that it shall perform in satisfactory operating condition or to replace it with new Goods at Supplier's cost so that the goods shall perform in accordance with the specifications and details as set forth in the Contract/tender documents. If the Supplier shall fail to do so after expiry of 15 days notice to this effect served on him by the Company, the Company shall be at liberty to repair, replace and/or reconstruct the Goods at its costs provided in the event, the Company shall be entitled to recover total cost of such replacement from the Supplier withdrawing from the Performance Guarantee.

36. **Language:**

The bid prepared by the bidder and all correspondence and documents relating to the bid exchanged by the bidder and the Company shall be written in English language. Any printed literature furnished by the bidder may be written in another language provided that this literature is accompanied by an English translation in which case for purpose of interpretation of the bid, English translation shall govern.

37. **Vehicle Applied by Authorized dealer of local manufacturer :**

In case of vehicle supplied by authorized dealer of local manufacturer, the authorized dealer will be responsible to get the vehicle (s) registered through Excise Department Government of Sindh and provide Original Registration book / Original Registration Invoice / Tax payment receipt / other related documents & provide the vehicle (s) number plate (s) to SSGC. Registration fee will be reimbursed by SSGC subject to submission of Government of Sindh Excise Department receipt.



Additional Terms for Tenders on F.O.B/C&F basis:**1. Submission of bids:**

- 1.1 Bid bond (Honest money) @ 2% of the total F.O.B value as per clause 9 of section 1 of "General terms & conditions" is required to be submitted with the bid. It may be noted that bids without bid bond will be rejected and returned to bidder.
- 1.2 In case the bidder is manufacturer the bid shall either be completely prepared by the foreign bidder including signing and stamping of all documents. In case, such documents are being signed by the local agent of the bidder, the bid shall essentially include supplier's original Performa invoice and an original authority letter in favor of local agent to sign the documents on their behalf. The bid is liable for rejection if these conditions are not met.
- 1.3 In case of Bidder offering to supply goods which the bidder did not manufacture or otherwise produce, the bidder shall be duly authorized by the goods manufacturer or the producer to submit bid or supply the goods on their behalf.
- 1.4 Bids shall be submitted (preferably through local agents) in two copies, (original + copy).
- 1.5 The price on unit FOB and C&F basis is to be quoted separately. Following are to be essentially indicated in the bid form:
 - 1.5.1 Country of origin.
 - 1.5.2 Port of shipment.
 - 1.5.3 Estimated gross/net weight, dimension & volume of offered item and estimated weight of each item.
 - 1.5.4 Delivery period or schedule in case of bulk quantities.
 - 1.5.5 Original technical literature.
 - 1.5.6 Beneficiary's complete address.

1.6 Foreign bank charges and L/C confirmation charges will be borne by the supplier.

1.7 Bid Currency:

The rates shall be quoted in bidder's home country or in United States Dollars. A bidder expecting to incur a portion of its expenditures in the performance of the contract in more than one currency and wishing to be paid accordingly shall indicate the same in their bid. However, bidder from Pakistan would be paid in Pak Rupee.

(Clause 1.5 of General Terms & Conditions is not applicable)

2. Bid bond:

2.1 Bid bond shall be equivalent to two percent (2%) of the total F.O.B value, in favor of Sui Southern Gas Company Limited and shall be in the form of pay order, demand draft, call deposit receipt or a bank guarantee (specimen attached at Annexure-A), issued by a scheduled bank in Pakistan. The bid bond shall remain valid for 120 days (150 days in case of Single Stage Two Envelope bidding procedure) unless specified otherwise. The bid bond shall be returned/refunded to the un-successful bidders while the bid bond of the successful bidder shall be retained, till submission of Performance bond. Bids without bid bond will not be considered. In case the order value is less than US\$25,000 the bid bond in lieu of performance bond, will be retained till fulfillment of obligations by the supplier. However, in either case the bidder is responsible to arrange the extension of bid bond validity as per requirement. If bid bond submitted by the supplier is more than 2% of ordered value, it may be replaced with appropriate value. Bid bonds of non-compliant bidders may be released during evaluation process. The bid bond shall be denominated in the currency of the bid or any other freely convertible currency.

2.2 Bid submitted on behalf of different principals shall be required to submit separate bid bond along with the bid for each offer.

(Note as mentioned at Clause 9, 9.1 & 9.2 of General Terms & Conditions shall also apply).

3. Conversion to single currency:

In order to carry out evaluation and comparison, the Company will convert all bid prices expressed in various currencies to Pak Rupees at the buying exchange rates established by the State Bank of Pakistan or any other commercial bank in Pakistan for similar transactions on the date of opening of bids. In case of Two Envelope Bidding System, the exchange rates prevailing at the time of opening of Technical Proposals will be used for conversion and evaluation.

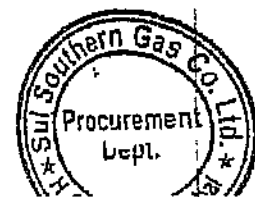

4. Evaluation Criteria:

- 4.1 The evaluation of bids will be carried out on C&F / landed cost basis, however purchase order will be placed on FOB price on freight to collect basis. The bidders are required to submit best freight charges obtained by them from Pakistan National Shipping Corporation (PNSC) in order to have a uniform basis to arrive at C&F cost. Bill of lading to indicate "freight payable by the consignee at destination" in local currency. Foreign currency exchange rate (selling) will be considered as of bid "opening date".
- 4.2 In the case of goods to be offered from outside Pakistan, custom duties and other similar import taxes which are applicable shall be added to the bid.
- 4.3 In case shipment by air it shall be arranged through Company's airfreight forwarder (s) or their nominated agent "on freight to collect basis".

(Clause No. 14.3 to 14.4 of General Terms & Conditions are also to be applicable).

5. Loading of Bids:

Freight charges from port of loading up to Karachi port or unit C&F value must be indicated in bid form, failing, which bid will be loaded by 5 to 10% freight charges. Bid will be declared non-compliant if loading results an extensive increase in price of material.

(Clause 15 of General Terms & Conditions is also applicable).

6. Performance bond:

- 6.1 In case purchase order value is US\$25,000/- or above or equivalent for other currencies, letter of intent will be issued to successful bidders for submission of performance bond guarantee which is to be submitted within 15 days from receipt of L.O.I. The successful bidders shall submit a performance bank guarantee (P.B.G) in the form of bank guarantee (specimen attached at Annexure-B) issued by a scheduled bank in Pakistan, for an amount equivalent to 10% of the total value of the purchase order or as specified, in the letter of intent. The performance bond unless specified otherwise, shall remain valid till:

- 6.1.1 Completion of final satisfactory delivery in case of consumable items.
- 6.1.2 12-18 months from the date of satisfactory delivery of the equipment/machinery.
- 6.1.3 Satisfactory delivery/installation of system in case the installation liabilities will be on supplier's part.
- 6.1.4 120 days in case of chemicals.

- 6.2 The Letter of Credit shall be operative upon receipt of Performance Bond (as specified in para 6.1) and integrity pact, any delay due to late submission of Performance Bond will be on supplier's account. Late submission of PBG should not affect the delivery schedule.

- 6.3 The performance bond shall be denominated in foreign currency or in currency of the contract/purchase order or in a freely convertible currency acceptable to the Company and shall be in the form of a bank guarantee.

- 6.4 In very special case subject to approval of the management, the P.B.G could be acceptable in Pak Rupee. However, an undertaking should be given by the supplier that in case of encashment of P.B.G. supplier shall deposit short fall amount due to Pak Rupee exchange rate.

6.5 Warranty/Guarantee:

In case where performance guarantee is not applicable, the supplier shall warrant that all goods supplied under the contract/purchase order are new, unused, of the most recent or current models and all recent improvements in design and goods have been incorporated, unless provided otherwise in the contract/purchase order. This guarantee shall remain valid for a period of twelve to eighteen months after the goods have been delivered or commissioned.

(Clause 16.2 to 16.8 of General Terms & Conditions are also applicable).

7. Delivery:

- 7.1 In case of "FOB" order/contract, shipments shall be effected per vessel of Pakistan National Shipping Corporation (PNSC) owned or chartered vessels on "freight to collect" basis. Bill of lading to indicate "freight payable by the consignee at destination". In case goods ready for shipment and the PNSC vessel is



not available at port of loading, supplier shall intimate the same to Company immediately so that matter could be taken with PNSC in Pakistan.

7.2 In case of C&F order/contract, the supplier hereby guarantees/ensure:

7.2.1 To use clean and dry vessel suitable for marine transportation and shall not use tramp vessels:

7.2.2 The goods/material will be shipped/dispatched with all care and diligence at their risk & cost and goods to be stored below deck. Accordingly, the supplier shall be responsible for all damages/losses during inland and marine transportation from the supplier's plant until arrival at Karachi port.

7.2.3 To provide as part of its work all services and functions related to handling, loading, unloading, lashing and securing in ship's holds and all costs, charges and expenses of which shall be included in the purchase order/contract price, unless otherwise specified:

7.3 In case of FOB order/contract, the supplier's obligations shall be over after the goods have crossed the ship's rails. The co-ordination, scheduling and lining-up for a PNSC vessel shall be the obligation of the supplier.

7.4 The supplier shall reimburse the Company all additional duties, taxes and other such charges paid by the Company on account of short shipment by the supplier for all items subsequently shipped on a no-charge basis or otherwise by the supplier. The supplier shall also reimburse the Company all additional duties, taxes and other such charges paid by the Company on account of incorrect invoicing by the supplier.

7.5 Shipment shall be deemed to have been made when the supplier has shipped the goods against a clean bill of lading and all other such documentation, as specified in clause 9.3 & 9.4 appearing next in sequence) have been furnished to the Company.

7.6 The supplier shall ensure that all above mentioned acts and other incidental and ancillary functions are conducted in accordance with sound and acceptable engineering practices. The Company shall be entitled to oppose any incorrect or inadequate practice adopted by supplier in this respect and the supplier shall take corrective action/measure forthwith to correct such omissions. If any goods are discovered to be damaged or unacceptable at the point of loading, the supplier shall be responsible for replacement free of all charges and costs to the Company within the delivery period specified in the purchase order/contract.

8. Insurance:

8.1 All goods supplied under the purchase order/contract shall be fully insured in a freely convertible currency against loss or damage incidental to manufacture or acquisition, transportation, storage and delivery in the manner specified in delivery clause 7.

8.2 Marine Insurance shall be the responsibility of the Company unless otherwise specified.

8.3 The supplier shall advise the Company by fax at least seven (7) days prior to the expected date of shipment, the following particulars:-

- 8.3.1 Name of the vessel and of the shipping company.**
- 8.3.2 Age of the vessel (which should be less than 20 years).**
- 8.3.3 Lloyds 100A1 or equivalent classification of the vessel.**
- 8.3.4 ETD from Port of dispatch and ETA at Karachi**
- 8.3.5 FOB/C&F value of the consignment.**

The above information shall also be transmitted to the Company's underwriters, M/s. National Insurance Corporation by fax No. 0092-21-9202779 and to the Company referring Policy No. NIF/M/K/OP/002/73.

9. Payment:

9.1 Payment of FOB/C&F prices shall be made in the currency of bid through an irrevocable letter of credit (L/C) established in favor of the supplier, negotiable through the bank of their choice. Bidder shall indicate full name and address of the negotiating bank and the place at which they wish to negotiate the letter of credit. All bank charges outside Pakistan will be on supplier's account and all bank charges within Pakistan will be at Company's account. If confirmed letter of credit is required then charges for confirmation will be on supplier's account.

9.2 The supplier's request (s) for payment shall be made to the Company in writing as follows:

9.2.1 It shall be accompanied by an invoice describing, as appropriate, the goods delivered and the services incurred and by shipping documents submitted pursuant to Clause 9.4 hereof and upon fulfillment of other obligations stipulated in purchase order/contract.

9.2.2 Against shipping documents on arrival of ordered material at consignee destination. Bidder (s) will have to clearly mention, if they wish to opt for this mode of payment

9.3 The letter of credit shall be available upon presenting the following documents to the negotiating bank within 15 days of the date of the bill of lading covering shipment of each consignment:



SSGC

- 9.3.1- Invoice --- 4 copies
- 9.3.2- Packing list --- 4 copies
- 9.3.3- Bill of lading * freight to be paid by consignee at destination* evidencing shipment in terms of the purchase order to Karachi-Pakistan made copies. out to order in the name of Co.'s bank, Notify party Sul Southern Gas Company Ltd. --- 3 originals & 6 non-negotiable
- 9.3.4- Certificate of Origin (Verified/ Endorsed by Chamber of Commerce) --- 2 copies
- 9.3.5- Manufacturer test certificate/ --- 2 copies Inspection report

9.4 Without prejudice to the supplier's responsibility for providing documents mentioned as at 9.3.1 to 9.3.5 above to bank, the supplier shall forward the following non-negotiable documents directly to Company immediately after shipment so as to reach the Company at least 15 days prior to the arrival of the vessel at Karachi port.

- 9.4.1 -Invoice --- 6 copies
- 9.4.2 -Bill of Lading --- 6 copies
- 9.4.3 -Packing List --- 6 copies
- 9.4.4 -Certificate of Origin (Verified/ Endorsed by Chamber of Commerce) --- 2 copies
- 9.4.5 -Manufacturer Test Certificate/ --- 2 copies
- 9.3.1- --- Inspection Report

9.5 The invoice to be exactly as per order/contract. Any deviation which renders or causes the Company to pay damage or any other charges with respect to clearance/handling etc. will be borne by the supplier. (non-negotiable)

9.5 No payment hereunder shall be deemed to be accepted by the Company of the goods covered by such payment nor release the supplier from responsibility thereof under the terms of the purchase order/contract.

9.6 If the Company is compelled to pay damage or storage charges or incurs any loss or suffers any damage at Karachi Port on account of non-compliance by the supplier of above requirements, the Company shall be entitled at their sole discretion to recover the same amount from supplier.

10. Termination of purchase order by supplier

10.1 The supplier shall have the right to terminate the contract/purchase order if:-

10.1.1 The Company fails to establish the letter of credit within the stipulated period as required under clause 9.1 hereof after the supplier has made compliance with the provisions of clause 6.

10.1.2 The Company becomes bankrupt or insolvent or makes an assignment for the benefit of its creditors.

10.1.3 The Company is in default and breach of its obligation and liabilities under the contract/purchase order.

11. Installation/Commissioning/Training:

If installation/commissioning and training is required, the charges will be paid in Pak Rupee and will be subject to deduction of all local duty and taxes (as applicable).

12. Vehicle (s) supplied by foreign manufacturer / principal

12.1 In case of supply of any type of vehicle (s) / earth moving vehicle (s) by the foreign principal / manufacturer. After clearance of vehicle from the custom, the local agent of the foreign supplier / manufacturer / principal will be completely responsible to get the vehicle (s) registered through Excise Department Government of Sindh and provide Original Registration book / Original Registration Invoice / Tax payment receipt / other related documents & provide the vehicle (s) number plate (s) to SSGC. Registration fee will be reimbursed by SSGC subject to submission of Government of Sindh Excise Department receipt.

12.2 The bidder / supplier shall quote only those vehicle (s) / which fully comply to Pakistan environment and can operate in Pakistan. The bidder should ensure that vehicle is; compatible to (fuel/oil & lubricant) types; are easily available in Pakistan.



SECTION - 1B	of Services
--------------	-------------

General Terms & Conditions**1. Definitions and Interpretation:**

1.1

In these tender documents (as hereinafter defined) the following words and expressions shall have the meaning hereby assigned to them except where the Tender requires otherwise.

- a) **Company** means the Sui Southern Gas Company Limited; a Company registered under statutes of Pakistan and includes any successors-in-interest or assignees.
- b) **Engineer** means the Engineer(s) nominated by the Company to look after and supervise the Work.
- c) **Representative of the Company** means a duly authorized person appointed by the Company or as specified in the "Special Conditions of the Contract" to perform the assigned duties.
- d) **Bidder** means any person or persons, firm or company bidding for the Work.
- e) **Contractor** means the persons, firm or company whose Tender (as hereinafter defined) has been accepted by the Company and includes the Contractor's representatives, sub-Contractors, successors and permitted assignees (Prior to the execution of the Contract the word "Contractor" also means a Tenderer or Bidder submitting a proposal in accordance with the Tender Documents).
- f) **Agent or Representative** means person(s) appointed by the Contractor to perform duties as set forth in the Contract.
- g) **Laborers/Workmen** means such laborers/workmen and staff as may be employed by the Contractor for purpose of carrying out the Work.
- h) **Sub Contractor** means any firm or person having a direct Contract with the Contractor. Nothing contained herein however, shall be deemed or be construed to impose upon the Company, any obligation, liability or duty to a sub-contractor or to create any contractual relation between any sub-contractor and the Company.
- i) **Work** means whole of the Works / Services or part thereof to be executed in accordance with Tender / Contract documents, whether temporary or permanent and whether original, altered substituted or additional.
- j) **Contract Documents** shall consist of duly executed Articles of Agreement, the Tender Documents and the Tender submitted by the successful Bidder including modifications thereto incorporated in the documents before and after the execution of the Contract.
- k) **Contract Price/Value** means the sum named in Schedule of (SOR) / BOQ subject to additions thereto or deductions there from as may be made under the provisions hereinafter contained.
- l) **Plant** means all machineries, equipment, materials, appliances or things of whatsoever nature required in or about the execution, completion or maintenance of the Work, but does not include such equipment, materials, appliances or things intended to form part of the permanent Work.
- m) **Temporary Works** means all temporary works of every kind required in or about the execution, completion or maintenance of the Work.
- n) **Drawings** means the drawings referred to in the Contract documents and any modification of such drawings.
- o) **Location** means the land and other places on, under in or through which the Work is to be executed or carried out and other lands or places provided by the Company for the purpose of the Contract.
- p) **Approved/Approval** means approved/approval in writing by Company's representative or as specified in "Special Conditions of Contract".
- q) **Tender/Bid** means the offer tendered by the Bidder for the Work governed by the Contract.
- r) When the terms Acceptable, Satisfactory, Proper, or other such general qualifying terms are used in the Contract, it shall be understood that reference is made to be sole ruling and the sole judgment of the Company.
- s) The Word Equivalent or Equal where used in these documents in the general sense shall not mean Similar but shall mean "Conforming to, Like, of Kind/Quality and Function". "Proprietary Items" and "Trade Names" are used for the purposes of establishing a standard of "Kind, Quality and Function" and "Equipment" items, articles, things or materials will be approved, if held to be "Equivalent" by the Company.
- t) **Approved Banker** wherever occurring in this Contract shall mean a Scheduled Commercial Bank operating in Karachi and acceptable to the Company.

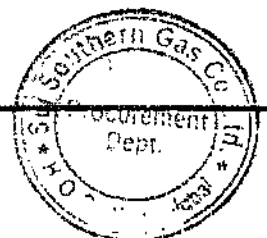

- u) **Specification(s)** means the standard codes of practice and other specifications issued with the Tender and any notification such as specifications approved in writing by the Company and other specifications as may from time to time be furnished or approved in writing by the Company.
- v) **Month** means calendar month of the Christian era.
- w) **Time Schedule** is a graphical illustration of the time span of various Work activities defining starting and completion dates.
- x) **Bonds** mean Bid Bond, Performance Bond or Bank Guarantee and other instruments of security furnished by the Bidder of his surety in accordance with the Tender/Contract.
- y) **Completion Date** means the date on which the Work has been completed in accordance with the Contract so that it can be utilized for intended purpose.
- z) **Day** means a day of 24 hours mid night to mid night.
- aa) **Completion Period** means the time allowed for the execution of the Work.

- 1.2 Words importing the singular only also include the plural and vice-versa where the Contract so requires.
- 1.3 The marginal headings or notes in these Conditions of Contract shall not be deemed to be part thereof or be taken into consideration in the interpretation or construction thereof or of the Contract.
- 1.4 If there is any conflict between the Special Conditions and the General Conditions, the Special Conditions shall modify, supplement and supersede the General Conditions.

2. **Examination:**

Bidders shall visit/inspect/examine the Work & Location and shall fully acquaint themselves with the nature and requirements of Work/Services, access to Work/Location, availability of materials, weather, law and order and local conditions etc. before submitting their Bids. Submission of the Bid shall be prima facie evidence that the Bidders have fulfilled this requirement and shall be binding upon him.

3. **Conflict between Drawings/Specifications/SOR:**

In case of any conflict between drawings/specifications, SOW/TOR and SOR/BOQ, with regard to the quality of any item, the Contractor / Consultant shall base his quotation for the better quality. In case of any deficiency in the drawings/details, the Contractor / Consultants shall seek clarification from the Company. Submission of Bids/rates on the basis of incomplete drawings/details shall be Contractor / Consultant's sole responsibility.

4. **Additions, Deletions:**

The Company reserves the right to make addition (Upto 15 %) and delete the quantity from the Work defined in SOW/TOR/SOR/BOQ as deemed necessary before or after the execution of the Contract. All such additions and deletions shall only be authorized in writing by the Company.

5. **Schedule of Requirement:**

The quantities specified in the SOR/BOQ are estimated and are intended to serve only as a guide to the Bidders. Payments shall be made on the basis of actual Work quantum done as measured. No claims or adjustments shall be entertained/allowed on account of increase or decrease in the Scope of Work which has not been duly authorized by the Company through the issue of change orders as stipulated in the relevant provision.

6. **Rate:**

The Bidder shall quote all item rates and lump sum prices as shown in the "SOR/BOQ". Bidders shall fill in the rate / price for each item in the SOR/BOQ. In case of any discrepancy between item rate and the amount, the quoted item rate will prevail. The quantities given in the SOR/BOQ are estimated ones and are subject to variations. That is, there could be increase or decrease. Nevertheless, the item rates quoted by the Bidder shall remain fixed and no escalation whatsoever shall be permissible. The rates / prices quoted by the Bidder shall be workable. The Bidder shall be required to furnish a complete rate analysis of any item in the SOR/BOQ as considered necessary, by the Company.

7. **Escalation:**

It may be clearly understood that this tender does not contain a price variation clause and therefore, all unit prices quoted shall be firm, irrevocable fixed and valid until completion of the Contract and will not be subject to variation on any account.

8. **Validity:**

Bids shall remain valid for acceptance for a period of (120) days from the date of bid opening. If the last date falls on a holiday, the validity will be extended to the first Company working day thereafter.

9. **Bid Bond (Earnest Money):**

The Bidder is required to furnish Bid Bond strictly in accordance with the prescribed format, in the form of a Pay Order, Demand Draft or Bank Guarantee issued only by a scheduled commercial bank operating in Karachi, for an amount fixed bid bond as specified of tendered Work / Services quoted by the Bidder in favor of Sui Southern Gas Company Limited. No Bid shall be considered without a Bid Bond and no cash or cheque or a guarantee issued by an insurance company shall be accepted.

The Bid Bond shall remain valid for a period of 150 days from the date of Bid opening. Bid Bonds of the unsuccessful Bidders shall be returned as soon as practicable, The successful Bidder's Bid Bond shall be retained by Company until execution of a Contract for the Work / Services defined in these documents and the submission of a Performance Bond prior to the execution of Contract.

In the event that the successful Bidder refuses or fails to provide (PBG) and Stamp papers for contract within fifteen (15) days of the issuance of a Letter of Intent, Company shall be at liberty to forfeit the Bid Bond.

In the event of the bid bond validity falling short of the prescribed period of 150 days as the case may be either (i) due to extension in the bid submission date or (ii) where so required by the procuring agency, than in such an event it shall be mandatory on the bidder to extend the bid bond validity up to 150 days within 30 days of the opening of technical proposal / bid, and / or where so required by the procuring agency.

In case when bidder submit alternate bids a separate bid bond for each bid is required otherwise bid will be liable for rejection. In case of Single Stage Two Envelope bidding system (bid bond will be enclosed with "Financial" bid, unless and until specified separately in Tender terms).

The bid bond may be forfeited if a bidder withdraws the bid during validity period specified by the bidder or if successful bidder fails to:

- Accept purchases order/LOI,
- Furnish performance guarantee in accordance with clause 10 of General Terms & Conditions,
- Extend Services as per requirement and completion Period.

10. Performance Bond:

The Bidder shall furnish a Performance Bond strictly (if the bid increases to Rs. 500,000/-) in accordance with the prescribed format in the form of a bank guarantee issued by a scheduled commercial bank operating in Karachi for an amount equivalent to _____ () percent of the Contract value. Failure to furnish the performance Bond before execution of the Contract will entitle the Company to consider the Bidder as having abandoned the Contract and the forfeit the Bid Bond. The Performance Bond shall remain valid till after three (03) month of completion of the work.

The Company's right to recover damages from the Bidder for breach of Contract shall not be limited to the value of the Performance Bond. In the event of the Bidder failing to execute a formal Contract or to submit the Performance Bond in the manner aforesaid and in the period specified, the Company shall be entitled to appropriate the earnest money submitted by the Bidder with his tender without prejudice to its right to claim any further loss or damage which may result to it by reason of the aforesaid default of the Bidder as if Contract is actually executed for the purpose of such claims.

The Bidder shall extend the validity period of the Performance Bond for such period(s) as required for the Contract performance.

The performance bond of the successful bidder will be released after successful completion of work.

11. Retention Money:

The amount to be retained from payments shall be equal to the specified percent of certified value of Work which would be released after the maintenance period.

12. Completion Period:

Subject to any requirements as to completion of any portion of the Work before the completion of the whole of Work, the Work shall be completed within the specified completion period. The Work shall not be considered as completed until the Company has certified in writing that it has been completed. Should extra, altered or additional Work of any kind, or any other cause of delay, which in the opinion of the Company could not have been foreseen by the Contractor / Consultant requires extension in completion time, then on the written request of the Contractor / Consultant, the completion period as provided in the Contract shall be extended by the Company. All such extensions shall be allowed in writing by the Company's representative.

13. Signing / Execution of Contract / Agreement:

Formal signing / execution of Contract / Agreement shall be completed within fifteen (15) days of receipt of "Letter to Proceed". The Company shall prepare the Contract in accordance with the prescribed format (Contract Form, and Articles of Agreement) for the purpose and the successful Bidder shall be communicated the date and time by the Company for the execution of Contract.

The successful Bidder shall provide the stamp paper, of value at the rate of thirty five (35) paisa per every hundred Rupees or part thereof of the amount of the Contract, or at the prevailing rate as specified by the Government of Pakistan.

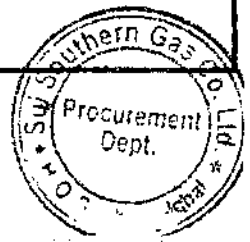

In case the agreement is executed for services i.e Janitorial, Canteen, Landscaping, Maintenance Contract etc.... will be for One year extendable for further Two terms of one year each unless specified in Special Term & conditions.

14. **Award / Evaluation Criteria:**

Company reserves the right to settle the final award of job to the technically compliant and lowest evaluated and commercially responsive bidder.

Evaluation may be carried out both on item or on group of items/single or multiple package basis depending upon the nature of requirement exclusively at the discretion of the company to ensure economic procurement.

15. **Commencement & Execution of Work:**

Notwithstanding any delay in the preparation / execution of the Contract the successful Bidder shall commence mobilization / preparations and under take the Work within (15) days after receipt of the Letter to Proceed.

The Contractor / Consultant shall prior to commencement of Work, obtain the written authority and instructions of the Company.

16. **Change in Orders:**

The Company may at any time, by a written notice to the Contractor / Consultant, make changes within the general Scope of Work of the Contract.

Upon notification by the Company of such change, the Contractor / Consultant shall submit to the Company an estimate of costs for the proposed change (hereinafter referred to as a change) within ten (10) calendar days of receipt of notice of the change, and shall include an estimate of the impact (if any) of the change on the completion date (s) under the Contract, as well as detailed schedule for the execution of the change, if applicable.

The Contractor / Consultant shall not perform changes in accordance with above, until the Company has authorized a Change Order in writing on the basis of the estimate provided by the Contractor / Consultant.

Changes mutually agreed upon as a change shall constitute a part of the Work under this Contract, and the provisions and conditions of the Contract shall apply to said change.

17. **Assignment:**

The Contractor / Consultant shall not assign, in whole or in part, its obligations to perform under the Contract except with the Company's prior written consent.

18. **Termination of Contract:**

The Company may decide to terminate the Contract in one of the following situations:

(i) **Termination for Default:**

The Company may, without prejudice to any other remedy for breach of Contract, by written notice of default sent to the Contractor / Consultant, terminate the Contract in whole or in part.

- (a) If the Contractor / Consultant fails to complete the contracted Works / Services within the time period(s) specified in the Contract or any extension thereof granted by the Company.
- (b) If the Contractor / Consultant fails to perform any other obligation(s) under the Contract.
- (c) If the Company during the completion period of the Contract has reason to believe that the Contractor / Consultant will not be able to fulfill the obligations under the Contract.

Prior to the exercising of any right by the Company to terminate the Contract, the Company shall issue notice to the Contractor / Consultant specifying the default(s) and the Contractor / Consultant shall submit an explanation within seven (07) days of receipt of such notice. If such explanation is not furnished within the stipulated time or if so furnished, is found to be unsatisfactory and / or the default(s) continues, the Contract may be terminated by the Company.

(ii) **Termination for Insolvency:**

The Company may at any time terminate the Contract by giving written notice to the Contractor / Consultant, without compensation to the Contractor / Consultant, if the Contractor / Consultant becomes bankrupt or otherwise insolvent. Notwithstanding the above such termination will not prejudice or affect any right of action or remedy which as accrued or will occur thereafter to the Company.

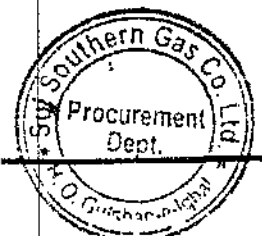

(iii) **Termination for Convenience:**

- a. The Company may by written notice sent to the Contractor / Consultant, terminate the Contract, in whole or in part, at any time for its convenience. The notice of termination shall specify that termination is for the company's convenience, the extent to which performance of work under the Contract is terminated and the date upon which such termination becomes effective.
- b. The Works that are complete and ready for Commissioning within thirty (30) days after the Contractor / Consultant's receipt of notice of termination shall be at the Contract prices and on the existing Contract terms. For the remaining Works, the Company can also opt to have any portion thereof completed and commissioned at the contract prices and on the other contract terms.

19. **Liquidated Damages:**

If the Contractor / Consultant fails to complete the Work or perform the Services specified in the Contract within the stipulated period / scheduled time specified in the Contract, the Company, without prejudice to any other remedies, shall deduct from the bills or any other due payments / guarantees, as liquidated damages, a sum equivalent to 0.1 % per day of the value the Contract, until actual completion of the Work or performance of the Services. However if delay of over 100 days takes place (i.e. equal to 10%), the Company reserves the right to terminate the Contract at the risk and cost of Contractor / Consultant. The liquidated damages shall also be applicable for the Works / Services terminated under Clause 16.

The payment of liquidated damages shall not relieve the Contractor / Consultant from performing and fulfilling all its obligations under the Contract and nor shall the rights and entitlements of the Company be affected or reduced in any manner.

20. **Force Majeure:**

The parties will not be considered to be in default in the execution of their contractual obligations or any of them to the extent that the execution of such obligations or any of them is delayed or omitted by cause of Force Majeure. Each party will advise the other party by written notice within 07 days of the occurrence of any such case of Force Majeure. The term Force Majeure employed herein shall mean acts of public enemy, wars (whether declared or not) invasion, hostilities, revolution, epidemics, riots (other than among the Contractor / Consultant's own employees) fires, floods, earth quake, commotion, disorder and other causes similar in kind to those herein mentioned, not under the control of either party, which makes the performance of this agreement unfeasible and which by the exercise of due diligence the party seeking excuse from performance is unable to overcome.

The Company shall not be liable to the Contractor / Consultant for any damage or loss caused by Force Majeure directly or indirectly.

21. **Safety of Employees and Works:**

The Contractor / Consultant shall be responsible to take all necessary precautions for the safety of employees on or off the Work, and shall comply with all applicable safety laws and codes to prevent accidents or injury to persons on about or adjacent to the places where the Work is being performed. All statutory rules, orders, regulation from time to time in force relating to taking and observance of all safety precaution governing or which might be deemed to be given during the execution and performance of the Work. The Contractor / Consultant shall comply with any and all personnel safety regulations. Any person of the Contractor / Consultant violating the safety rules shall be removed by the Contractor / Consultant from site and replaced without delay.

22. **Insurance:**

The Contractor / Consultant shall be responsible for obtaining a Contractor / Consultant's All Risk Policy (CAR) against risks to the Works and shall make good at his own cost, all losses or damages whether to the Works or to the lives, persons, whether under the workmen's compensation Act or Third Party Risk, or property of others from whatsoever cause arising out of or in connection with the works either during the progress of the works or during the period of maintenance provided by this Contract.

The Contractor / Consultant shall arrange insurance approved by the Company fully to cover workmen compensation and other claims arising out of sickness, injury or death of his personnel working at site and also to cover theft, loss of or damage to the Company's material in his possession and to indemnify the Company for third party claims for damage done or said to have been done to those persons or their property as a result of the Contractor / Consultant's activities on and off the site.

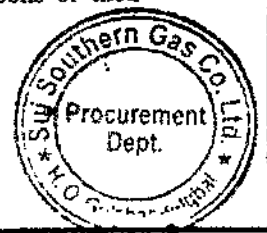

Insurance will be required where ever applicable:**Company's Address:**

**GENERAL MANAGER (PROCUREMENT)
SUI SOUTHERN GAS COMPANY LIMITED,
2ND FLOOR, HEAD OFFICE, ST-4/B, B-14,
SIR SHAH SULEMAN ROAD,
GULSHAN-E- IQBAL,
KARACHI -PAKISTAN.**

Contractor / Consultant's Address:

23. Dispute Resolution:

If any dispute shall arise as to the interpretation of this Contract or any matter or thing arising there from, the same shall be settled as far as possible by way of amicable resolution. Failing such settlement, the dispute may be referred for arbitration to two Arbitrators, one to be nominated by each Party. The appointed Arbitrators shall before proceeding on the reference appoint an Umpire. The Award given by the Arbitrators or the Umpire as the case may be shall be final and binding on the Parties. The proceedings shall be governed by the Pakistan Arbitration Act, 1940 and any statutory modification thereof. The venue of arbitration shall be Karachi.

All costs of Arbitration shall be borne by the Parties themselves, unless otherwise ordered by the Arbitrator. Notwithstanding the existence of any difference or dispute, or the commencement or continuance of any arbitration proceedings, Works to be done or Services to be provided under this Contract shall not be suspended or discontinued by the Contractor / Consultant nor shall any payment be withheld by the Company except the difference of the amount in dispute, which is the subject matter of such proceedings.

24. Income Tax and Duties:

All kinds of Government Taxes and Duties (income tax, custom duties, etc.) also the provincial sales tax as per provincial law, against any item of the contract, shall be entirely the responsibility of the Contractor / Consultant. Income Tax will be deducted as applicable under the prevailing Government Rules. Rate of Income Tax deduction in relation to submission of Income Tax certificate from the Contractor / Consultant should also be stipulated.

All Foreign Service providers are required to obtain Advance Ruling from the Federal Board of Revenue (FBR) under Section 206A of the Income Tax Ordinance 2001 (Pakistan's Income Tax Law). The advance Ruling issued by FBR covers application of Income Tax Ordinance 2001 to Transaction proposed or entered in to Foreign Service Provider".

25. Payments:

Payment will be made within 30 days after completion of works.

The Contractor / Consultant shall submit to the Company during the execution of the Work on-account bills along with a statement / details of executed Work.

The rates and prices in such on-account bills and statement of Work shall be in accordance with those in the SOR/BOQ so far as such rates and prices are applicable and on the approved rates and prices for other items of Work. All payments against on-account bills shall be treated as provisional payments and will be subject to final adjustment.

The Company may withhold payment or on-account of subsequently discovered evidence, nullify the whole or part of any certificate to such extent as may be necessary to protect itself from loss on-account of:

- (a) Defective Work not remedied.
- (b) Claims filed or reasonable evidence indicating probable filling of claim.
- (c) Failure of the Contractor / Consultant to make payments properly to Sub-Contractor / Consultants.
- (d) Damage to another Contractor / Consultant.

When the grounds are removed payment shall be made for amounts withheld because of them.

Payments in respect of extra / additional Work will be made on the basis of the original Contract rates and the Contractor / Consultant will not be entitled to any extra compensation / payment including idle charges because of such delays.

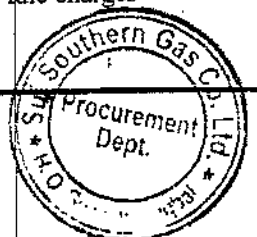

The making and acceptance of the final payment after successful completion of Work shall constitute a waiver of all claims by the Company other than those arising from faulty Work appearing after final payment and of all claims by the Contractor / Consultant, except those previously made and still unsettled.

Supplier (s) are required to submit signed and stamped acknowledgement slip, Sale Tax return, Annex "C" & Annex "T" (whichever applicable) in which Sales Tax (of relevant Sales Tax invoice) is paid.

26. Blacklisting of Suppliers and Contractor / Consultants:

The company shall permanently blacklist or temporarily debar (at least for 6-months from participating in SSGC's tender proceeding) if, a supplier or Contractor / Consultant who either constantly fails to perform satisfactorily or found to be indulged in corrupt and fraudulent practices as defined blow:

- 26.1 Corrupt and fraudulent practices" includes the offering, giving, receiving, or soliciting of anything of value to influence the action of an official/company.
- 26.2 If the supplier/Contractor / Consultant found responsible for the detriment of the company during proceedings of procurement/contract, process or its execution.
- 26.3 Misrepresentation of facts (by providing fake documents, concealing, mis-reporting facts pertaining to the bid) in order to influence the procurement process or the execution of the purchase order/contract.
- 26.4 Collusive practices among bidders (prior to or after bid submissions) designed to establish bid prices at artificial, non-competitive levels and to deprive the company of the benefits of free and open competitive.

27. GOP's Obligation:

The contract shall be governed by the Law of Pakistan. The Contractor / Consultant is obligated to comply with all regulations and ordinance in force or to be passed by the Government of Pakistan in connection with Labor legislation during the course of the work to be performed. Any additional financial charges on account of revision in minimum wages by GOP will be company's responsibility while the contract is in operation.

This contract embodies the entire understanding of the parties hereto on this subject and there are no commitment, terms, conditions or obligations, oral or written, express or implied, other than those contained herein.

28. Late Bid:

Sealed bids shall be mailed/submitted/dropped in tender box placed at Tender Room, CRD Building, and SSGC Head Office, In accordance to the time specified in invitation to bid & tender notice (which ever applicable), Bids are to be delivered on or before closing time after which all bids submitted after the time prescribed shall not be entertained and will be returned without being opened. In case bid is sent through courier, the same shall be delivered at least half an hour before scheduled opening time.

29. Rebate / Discount:

Unit rate (s) given in the Bill of Quantities shall take into account all relevant factors including discount if any. Discount given separately at the time of bid opening will not be considered.

30. Joint Ventures:

In the event that the bidder is bidding as a Joint Venture, the Company will require the joint venture agreement duly executed by the parties to the Joint Venture to be submitted with the bid. The joint venture parties shall also furnish an undertaking to be jointly and severally liable for all liabilities arising out of obligation under the Purchase Order / Contract. The Joint Venture agreement of the parties must specify share of each partner and name of the lead partner along with their registration with the FBR, SST and BST as the case may be failure to specify these two narrations the joint venture agreement will not be entertained.

31. Correction / Amendments in Quoted Price:

Any overwriting in BOQ / SOR is not allowed. In case of type of any amendment / correction required in unit price / total amount the same has to be strikeout and re-written with corrected figures, properly signed & stamped out, in order to avoid an ambiguous bid.

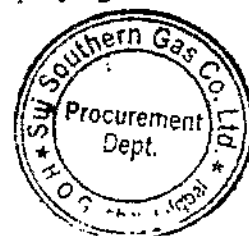



SSGC

SSGC/LP/EPADS/ /

Annexure - A

On Non Judicial Stamp Paper of Rs. 50/- (Fifty) Per 100,000
Form of Bid Bond Guarantee

BANK GUARANTEE NO.....
DATE OF ISSUE.....
DATE OF EXPIRY.....
AMOUNT.....

Sui Southern Gas Company Limited,
ST. 4B, Block-1A,
Gulshan-e-Iqbal,
Sir Shah Sulaiman Road,
Karachi.

Dear Sir,

Bid Bond Bank Guarantee

In consideration of Mr. hereinafter called the Bidder
having submitted the accompanying bid & in consideration of value received from Bidder we hereby agree and
undertake as follows:

1. To make unconditional payment of Rs. upon your written demand without further recourse, question or reference to the Bidder or any other person in the event of withdrawal of the aforesaid bid by the Bidder before the end of the period specified in the bid after the opening of the same for the validity thereof or if no such period to be specified within 90 days (150 days in case of Single Stage Two Envelope bidding procedure) after said opening and or in the event that the Bidder shall within the period specified therein or if no period specified within 15 days after the prescribed forms are presented to the Bidder for signature the Bidder shall fail to execute such further contractual documents if any, as may be required by the terms of the bid as accepted or on the Bidder failure to give the requisite Performance Bond as may be required for the fulfillment of resulting contract.
2. To accept written intimation (s) from you as conclusive and sufficient evidence of the existence of a default of non-compliance as aforesaid on the part of Bidder and to make payment accordingly within 03 days of the receipt of the written intimation.
3. No grant of time or other indulgence to, or composition or arrangement with the Bidder in respect of the aforesaid Bid with or without notice to us shall in any manner, discharge or otherwise, howsoever, effect this Guarantee and our liabilities & commitments hereunder.
4. This Guarantee shall be binding on us and our successors in interest and shall be irrevocable.

Yours faithfully,

(stamp and signature of the issuing bank)



SSGC

Annexure - B

On Non Judicial Stamp Paper of Rs. 50/- (Fifty) Per 100,000
Format of Performance Bond Guarantee

BANK GUARANTEE NO.....
DATE OF ISSUE.....
DATE OF EXPIRY.....
AMOUNT.....

Sui Southern Gas Company Limited,
ST. 4/E, Block-14,
Gulshan-e-Iqbal,
Sir Shah Suleman Road,
Karachi.

SSGC/LP/.....

Dear Sirs,

In The Sum of Rs..... Account.....
-To You in Karachi under the Purchase

In consideration of your having placed Purchase Order No.....
dated..... On M/s..... called Supplier and in
consideration for value, received from Supplier, we hereby agree and undertake as under:

1. To make unconditional payments to you from time to time as called upon or make an unconditional payments Rs..... Being Ten Percent (10%), of the value of the Purchase Order price mentioned in the said Purchase Order, on your written demand(s) without further resource, question or reference to Supplier or any other person, in the event of default or non-performance and / or non-fulfillment by Supplier of his obligations liabilities & responsibilities under and in pursuance of the said Purchase Order of which you shall be the sole judge.
2. To accept written intimation from you as conclusive and sufficient evidence of the existence of a default or breach as aforesaid on the part of Supplier and to make payment accordingly within 3 (three) days of receipt thereof.
3. To keep this guarantee in full force from the date hereof as specified in General or Special terms & conditions.
4. That on grant of time or other indulgence to amendment in the terms of the purchase order by agreement with Supplier in respect of the Performance of his obligations under and in pursuance of the said Purchase Order with or without notice to us, shall in any manner discharge or otherwise, however, affect this Guarantee and our liabilities and commitments there under.
5. This Guarantee shall be binding on us and our successors in interest and shall be irrecoverable.
6. This Guarantee shall not be affected by any change in the constitution of the Guarantor Bank or the constitution of M/sthe Supplier.

Yours faithfully,

(stamp and signature of the issuing bank)

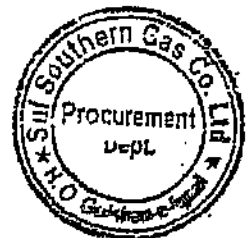

(Format of Declaration)

Annexure - C

General Manager (Procurement)
Sui Southern Gas Company Limited,
ST. 4/B, Block-14, Gulshan-e-Iqbal,
Sir Shah Sulaiman Road, Karachi.

SSGC/CP

Dear Sir,

Declaration

(the Seller/Supplier) hereby declares its intention not to obtain or induce the procurement of any contract, right, interest, privilege or other obligation or benefit from Sui Southern Gas Company Limited or any administrative subdivision or agency thereof of any other entity owned or controlled by it (SSGC) through any corrupt business practice.

Without limiting the generality of the foregoing, (the Seller/Supplier) represents and warrants that it has fully declared the brokerage, commission fees etc. paid or payable to anyone and not given or agreed to give and shall not to give or agree to give to anyone within or outside Pakistan either directly or indirectly through any natural or juridical person, including its affiliate, agent, associate, broker, consultant, director, promoter, shareholder, sponsor or subsidiary, any commission, gratification, bribe, finder's fee or kickback, whether described as consultation fee or otherwise, with the object of obtaining or inducing the procurement of a contract, right, interest, privilege or other obligation of benefit in whatsoever form from SSGC, except that which has been expressly declared pursuant hereto.

(The Seller/Supplier) certifies that it has made and will make full disclosure of all agreements and arrangements with all persons in respect of or related to the transaction with SSGC and has not taken any action or will not take any action in circumvent the above declaration, representation or warranty.

(The Seller/Supplier) accepts full responsibility and strict liability for making any false declaration, not making full disclosure, misrepresenting facts or taking any action likely to defeat the purpose of this declaration, representation any warranty. It agrees that any contract, right interest, privilege or other obligation or benefit obtained or procured as aforesaid shall, without prejudice to any other rights and remedies available to SSGC under any law, contract or other instrument, be voidable at the option of SSGC.

Notwithstanding any rights and remedies exercised by SSGC in this regard, (The Seller/Supplier) agree to indemnify SSGC for any loss or damage incurred by it on account of its corrupt business practices and further pay compensation to SSGC in an amount equivalent to ten times the sum of any commission, gratification, bribe, finder's fee or kickback given by (The Seller/Supplier) as aforesaid for the purpose of obtaining or inducing the procurement of any contract, right, interest, privilege or other obligation or benefit in whatsoever form from SSGC.

Yours faithfully,

Signature & Stamp (The seller/supplier)

Note:

1. The above declaration is required to be submitted by the Successful Bidder after issuance of Purchase Order (PO) or Letter of Intent (LOI) on Bidder's letter head, for purchase order / letter of intent of a total value of Rs. 10,000,000/- (Ten million) or above.
2. Please note that submitting the declaration is a mandatory requirement.



CONTRACT FORMContract No. SSGC/LP/EPADS/ 1ARTICLES OF AGREEMENT

THIS AGREEMENT, made and entered into this _____ day of _____, 2018 by and between Sul Southern Gas Company Limited, having its office at ST-4/B, Sir Shah Muhammad Suleman Road, Block 14, Gulshan-e-Iqbal, Karachi, hereinafter referred to as the "Company" of the one part and M/s. _____ hereinafter referred to as the "Contractor", (which expression shall include the successors, of the said firm, heirs, executives, administrators and assigns of the Partners of the said firm individually or severally) of the other part.

WITNESSETH:

WHEREAS, under the procedures, bids have heretofore been received by the Company for carrying out "_____ work and the tender of the Contractor for the said work has been accepted by the Company.

NOW THEREFORE, for and in consideration of the promises, negotiations, covenants and agreements hereunder contained and to be performed by the parties hereto, the said parties hereby covenant and agree as follows:-

Article-1 - Work and Cost of the Work

- i) In consideration of the covenants and agreements to be kept and performed by the contractor and for the faithful performance of this Contract and the completion of the work embraced therein according to the specifications and conditions herein contained and referred to or agreed to in course of subsequent negotiations and in accordance with the Contract, the Company shall pay and the Contractor shall receive and accept as full compensation for everything furnish and done by the contractor under this agreement as sum of approximately Rs. _____ or such other sums as may be ascertained in accordance with the conditions of Contract, etc. and at rates quoted against each item of work and agreed to and accepted by the parties as one instrument, and at the times and in the manner prescribed by the conditions of the Contract.
- ii) The Contractor at his own proper cost and expense shall do all work and furnish all labour, materials, tools, supplies, machinery and other equipment and plant that may be necessary for the satisfactory completion of all the works as set forth in the contract documents.

Article-2 - Time:

The maintenance of a rate of progress in the works at a rate which will result in its completion within the specified time, is of the essence of the contract and the Contractor agrees to proceed with all the due diligence and care at all times to take all precautions to ensure the timely completion as defined herein; time being deemed to be essence of the Contract of part of the Contractor.

The said work shall be started on the Contractor's receipt from the Company of a written order to proceed, and the Contractor shall have the work called for duly and fully complete in total _____ months (including _____ weeks mobilization period) from the date of issuance of such order.

Article-3 - Contract Documents:

It is understood and agreed that the contract documents which comprise this Contract are attached hereto and made a part hereof and consist of the following :-

- a) The Article of Agreement.



- b) Bid ((submitted vide letter No. _____, dated _____ comprising Letter of Invitation, Instructions to bidders, Scope of Work, Special and General Conditions of Contract, Tender Form, Bill of Quantities, Drawings, etc.).
- c) Company letter No. _____, dated _____.
Contractor letter No. _____, dated _____.
- d) Notice of Award (Letter of Intent (LOI) No.SSGC/MAT/S&C/_____, dated _____.
- e) Acceptance by the Contractor on the copy of LOI.
- f) Letter to Proceed No.SSGC/PROC/S&C/_____, dated _____.
- g) Performance Bank Guarantee No. _____, dated _____, amounting to Rs. _____ issued by M/s. _____.

It is agreed by the parties to the contract that this contract shall be executed in two counterparts; one copy to be retained in the office of the Sui Southern Gas Company Limited and one given to the Contractor.

IN WITNESS WHEREOF the parties hereto have executed this Contract at Karachi in two counterparts by their duly authorized representatives as of the day and year herein above set forth.

Signed for and on behalf of
M/s. Sui Southern Gas Company Limited

Signed for and on behalf of
M/s. _____ Karachi

Signature : _____

Signature : _____

Name : _____

Name : _____

In the presence of :

Signature : _____

Signature : _____

Name : _____

Name : _____

Signature : _____

Name : _____

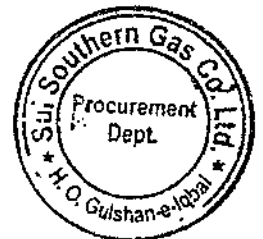



FORM "Y"
(SSGC – sample submission form)

SECTION A: BIDDER INFORMATION

FIELD	DETAILS
Bidder Name / Firm Name	
NIN / GST No.	
Address	
Contact Person	
Contact Number	
Email Address	
Declaration by Bidder	
I/We hereby declare that the sample(s) submitted are in accordance with the tender specifications and terms. I/We understand that failure to submit correct and complete samples may lead to disqualification.	
Signature of Bidder:	

SECTION B: TENDER DETAILS

FIELD	DETAILS
Tender No.	
Tender Opening Date	
Item(s) for which sample is submitted	
Quantity of Sample Submitted	
Specification/Description of Sample	
Make:	
Brand:	
Serial No:	
Generics: size, height, weight, width:	
Other description:	

SECTION C: FOR OFFICE USE ONLY (TO BE FILLED BY TENDER ROOM)

FIELD	DETAILS
Date & Time of Submission	
Received By (Tender Room Staff Name & Sign)	
Tender Room Stamp	
Remarks (if any)	

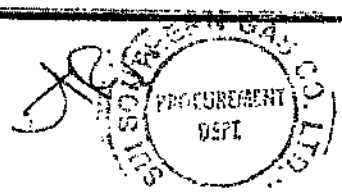

Annexure - G.

Supplier code: _____

FORM-X

Bank account details form for all Beneficiaries

(Mandatory requirement for Digital Online Banking)

As per FBR Regulations ref # C.No.4 (24) IT-Budget/2021-142150-R dated 23rd Sept'2021 to make the payment online w.e.f. 01-11-2021. All beneficiaries are required to fill in the below details, which is mandatory:

Name of Firm: _____

Address of Firm: _____

CNIC #: _____

NTN #: _____

Bank Name: _____

Bank A/C Title name: _____

Branch code: _____

Bank A/c #: _____

(16 Digits)

Bank IBAN #: _____

(24 Digits)

Information already submitted.

Note: Please be attached copy of Cheque / Account Maintenance Certificate.(Mandatory)

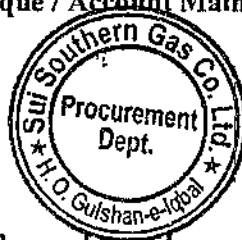

Authorized Sign & Stamp

Date: _____

Note: All payments transactions will be made on above mentioned Account details. This is only a one time information to be provided by the all beneficiaries. Incase if the above detail has already submitted, please tick the box above "Information already submitted" and also ensure Form-X is duly signed & stamped.

Section - 2
Special Conditions of Tender Document
Tender Enquiry No. SSGC/SC/

Note: In case of any conflict between special conditions of Tender Document and any other terms & conditions, the Special Conditions of Tender Document will govern / prevail.

- 1- Contractor to submit the following within 15 days after issuance of Letter of Intent (LOI).
 - a. Performance Bank Guarantee
 - b. Stamp Papers
 - c. Insurance Policy
 - d. Any other Document as mentioned in the LOI
- 2- Formal contract will be made on Non-Judicial stamp paper of value @ Rs 0.35 per hundred rupees of contract value, as per prevailing rate by Government of Sindh & Balochistan. The stamp duty will be borne by the contractor and also submit the copy of challan of stamp paper. Further as per Government of Sindh Board of Revenue notification NO.CIS/SWB/BOR/R&T-17/2022-308 dated 08-06-2022 all judicial and non-judicial stamp paper of the denomination of rupee five hundred and above shall be exclusively on e-stamp.
- 3- All kinds of Government Taxes, Duties and Levies against any item of the contract, shall entirely be the responsibility of the Contractor. Income Tax will be deducted as per applicable Law under the prevailing Government Rules. Rate of Income Tax deduction in relation to submission of Income Tax certificate from the Contractor should also be stipulated.
- 4- Bank Guarantee (Bid Bond Guarantee/Performance Bank Guarantee) will be made on Non-Judicial stamp paper at the prevailing rate as specified by the respective Provinces. Further the bidder/contractor submitting the Bid Bond guarantee/Performance Bank guarantee being prepared by the State Bank's schedule banks should ensure that there should be no deletion/insertion/alteration/modification of any terms in the Bid Bond/PBG guarantee format as given in the tender document or else bid will be liable for rejection.
- 5- If the letter to proceed (LTP) by user deptt. is not issued within six months after issuance of letter of intent (LOI), both the parties are at liberty to terminate/voke the LOI without any claim of loss or damage to the other party.
- 6- The completion period of the said work shall start with effect from the issuance of Letter to Proceed, which in case of work exigencies could be issued prior to signing of formal agreement.
- 7- In case of services and works tenders:
Bids determined to be substantially responsive will be checked by the Procuring Agency for an arithmetic error. Errors will be corrected by the Procuring Agency as follows:
 - a. Where there is a discrepancy between the amounts in figures and in words, the amount in words will govern ; and
 - b. Where there is a discrepancy between the unit rate and the line item total resulting from multiplying the unit rate by the quantity, the unit rates as quoted will govern, unless in the opinion of the Procuring Agency there is an obviously gross misplacement of the decimal point in the unit rate, in which case the line item total as quoted will govern and the unit rate will be corrected.
- 8- The bidder shall fill in rates and prices for all items of the works / services described in the BOQ. Item against which no rate or price is entered by a bidder will not be paid for by the Procuring Agency when executed and shall be deemed covered by rates and prices for other items in the BOQ. Any Bidder who change / amend the BOQ or Price Schedule (description, Quantity, UOM etc.) will render the bid as conditional bid and will be liable for rejection.
- 9- **Method For Submission of Bid Bond (Under Single Stage Two Envelope Bidding Procedure):**
In case of Single Stage Two Envelope Tenders the fixed bid bond as per clause#09 of General Terms & Conditions to be placed in the Technical Proposal. However, if the bid bond is placed in the financial proposal will also be considered. Without submission of bid bond (either in Technical proposal or financial proposal) the bid will be rejected.
- 10- Bid bond submission (2%) of the bid amount as mentioned in the clause 9 of General Terms & Conditions, to be treated as null & void, however other contents of clause 9 will remain unchanged. The submission of fixed amount of Bid security is appearing in the Schedule of Requirement/Bid Form.

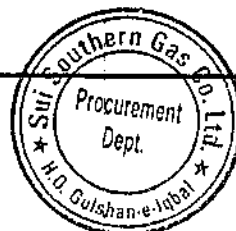

- a) All the bidders are advised to furnish fixed bid security (Original Instrument) as per amount appearing in Schedule of Requirement/Bid Form, failing which their bid will be rejected.
- b) The submission of fixed amount of bid security is also mandatory for all the bids valuing Rs.500,000/- or less.
- c) The word lowest bidder or the lowest evaluated bid has been substituted to read as **most advantageous bid**.
- 11- Bid shall remain valid for acceptance for period of (120) days from the date of public opening of the bids & Bid Bond validity is for 150 days.
- 12- In case the local agent requires to offer bid form more than one Principal / Manufacturer, it is mandatory to purchase separate tender document for each Principal / Manufacturer, failing which the bid submitted with the original tender document will only be accepted and the bid with photocopy of tender document will be rejected.
- 13- **Blacklisting Mechanism of Suppliers and Contractors and their Local Agent:**
Black listing mechanism is attached separately in the tender documents which will become an integral part of Tender Documents and now be followed / enforced in true letter & spirit and supersede the Black listing terms as mentioned in the General Terms & Conditions.
- 14- Original counter slip of token which is issued with tender document to be attached on the TOP of envelope at the time of bid submission"
- 15- The Successful Contractor(s) / Supplier(s) / Consultant(s) shall submit a copy of Professional Tax Certificate with their Invoices / Bills failing which the payment will not be released.
- 16- **Contracts of Contractors**
In the event the contractor is not willing to extend the CONTRACT for further term(s) / Period(s) under the same terms & conditions and the quoted price as defined in the bid documents, the contractor is liable to intimate in writing to SSGC at-least 3 (Three) months in advance prior to completion of the existing contract term / period, failing which, action will be taken as per tender terms.
- 17- **Insurance**
In addition to the Clause 22 -Insurance, of General Term and Condition, when The Successful Contractor(s) / Supplier(s) will submit Insurance Policy to SSGC, the Insurance Company (policy issuer) should be registered with SECP, otherwise the insurance policy will not be considered / rejected at contractor's risk and cost. The insurance coverage period will be according to the work completion period as mentioned in the contract / tender documents.
- 18- **Fixed Bid Security – Alternative Bid**
A bidder cannot submit two bids/offers with a single fixed bid security/pay order. However, the alternative bids/offers with separate fixed bid security/pay order can be accepted, failing which the bids will be liable for rejection.
- 19- **Bid Bond & PBG (Performance Bank Guarantee) for Proprietary Tenders**
In case of proprietary Tenders, the Bid Bond & Performance Bank Guarantee (PBG) are not required / Applicable.
- 20- SSGC will not pay invoices if they are turned in after 6 months of work completion / material delivered.
- 21- It is mandatory for the bidders to follow all the terms and conditions given in the tender documents without any addition / deletion / amendment and submit the bid accordingly. Therefore, in this context, the bidders are requested not to give their own terms and conditions as it tantamount towards the conditional bid. Otherwise their terms and conditions will not be considered and the Purchase Order / Contract will be awarded based on only as per SSGC tender terms and conditions.
- 22- The bidders/contractors are required to provide their only one Bank Account number (IBAN number) on the 'FORM-X' attached duly signed & stamped as one time information, which shall be firm (not changeable) for all the future payment transactions.
- 23- **Payment:**
The supplier after delivery of goods and its acceptance shall submit invoice to Finance Department of the Company, containing following information i.e.
- (a) Purchase order No. & date
 - (b) Items
 - (c) Quantity
 - (d) Price
 - (e) Invoice value
 - (f) Point of delivery
 - (g) Delivery challan indicating delivery date, etc.
 - (h) Supplier(s) are required to submit signed and stamp acknowledgement slip, Sales Tax return,



Annex "C" & Annex "I" (whichever applicable) in which Sales Tax (of relevant Sales Tax invoice) is paid. Payment will be made within 30 days of completion of stated requirements.

24. In case the insurance policy submitted by the contractor is expired during the execution of job, it is the responsibility of the user department to coordinate with the contractor to get it renewed/updated till the period the job is completed/commissioned.

In case the job is not completed within the given time as per tender terms and the insurance policy submitted by the contractor expires, the contractor is liable to get this insurance policy renewed / updated immediately till the period of the job is completed / commissioned as per tender terms failing which the contractor will be responsible for any loss to SSGC.

25. Bidders can quote their rates on both i.e. Schedule of Requirement/Bid Form as well as Bill of Quantity (BoQ)
26. Subsequent to the issuance of LOI, successful bidder has to submit 10% Performance Bank Guarantee of the contract value unless and until specified in the tender document.

27. Company reserve the right to award the Purchase Order /LOI to most advantageous bidder.

28. As per SRO 592(I)/2022 of PPRA Regulations, for Procurement Contracts/Purchase Orders worth of Rs. 50 million and above, bidders/contractors are required to submit the Beneficial Owner's Information for Public Procurement Contracts/Purchase Orders (Annexure-I).

29. Bidder will be blacklisted and henceforth cross debarred for participating in respective category of Public Procurement proceedings for a period of (not more than) six months, if fail to abide with a bid securing declaration (which is an integral part of tender document), however, without indulging in corrupt and fraudulent practices, if in breach of obligation(s) under the Bid conditions:

a) The bidder have withdrawn or modified their bid during the period of bid validity as specified in the tender terms.

b) Having been notified of the acceptance of bid by procuring agency during the period of bid validity (i) failure to sign the contract or accept purchase order (ii) fail or refuse to furnish the performance security or to comply with any other condition as mentioned in the tender document.

30. Wherever the "Rate Only" is mentioned (either on BOQ or anywhere in tender documents) the same shall only be applicable not exceeding 15% of the original procurement for the same items as given in the BOQ for package basis. In case the requirement is on item wise basis (not package basis) then not exceeding 15% of the original Procurement for the same items (on item wise basis) as given in the BOQ.

31. Lots: In case when the tender is floated on LOT basis, following clauses to be applied:

a) The bidder(s) are essentially / mandatorily required to submit fixed bid bond as mentioned in the bid form/BOQ/Invitation to Bid. Separate fixed bid bond to be submitted against each individual LOT and its validity to be 150 days at the time of opening of technical proposal.

b) Evaluation for each LOT will be carried out separately. Each LOT will be awarded separately.

32. For open competitive bidding if the most advantageous bidder is new local manufacturer, 10% trial order will be placed and remaining 90% order will be awarded to the next most advantageous bidder at their own quoted rates.

33. Redressal of Grievances And Settlement of Disputes:

- Any bidder feeling aggrieved by any act of the procuring agency after the submission of his bid may lodge a written complaint concerning his grievances within seven days of announcement of the technical evaluation report and five days after issuance of final evaluation report.
- In case, the complaint is filed against the technical evaluation report, the GRC shall suspend the procurement proceedings.
- In case, the complaint is filed after the issuance of final evaluation report, the complainant cannot raise any objection on technical evaluation of the report. Provided that the complainant may raise the objection on any part of the final evaluation report in case where single stage single envelope bidding procedure is adopted.

34. All the bidders are allowed to participate in the subject procurement without regard to nationality/origin, except bidders of some nationality/origin, prohibited in accordance with policy of the Federal Government. Following countries are ineligible to participate in the procurement process:

- India
- Israel

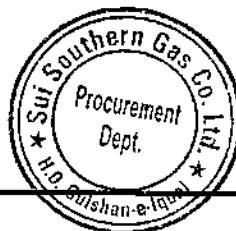

35. In Open Competitive Bidding Procedure where the quoted price is less than Rs. 500,000/- the Bid Bond will be retained in lieu of PBG.
36. In case the Bid Bond is not required, the bidder must submit the Form of Bid-Securing Declaration attached with the Tender Document else the Bid will be liable for rejection.
37. All Tenders floated through EPADS are to be governed by S.R.O. 296(I)/2023 dated: March 8, 2023 "E-Pak-Procurement Regulations 2023". In case of any conflict between SSGC Tender Terms / Instructions to Bidders and the PPRA EPADS Rules, the S.R.O. 296(I)/2023 will prevail.



**Tender Enquiry No. SSGC/LP/
Special Conditions of Tender Document**

Note: In case of any conflict between Special Conditions of Tender Document and any other terms & conditions, the Special Conditions of Tender Document will govern / prevail.

1. Warranty / Guarantee Coverage

i) The successful bidder / supplier guarantee that the goods supplied against above tender enquiry are in all respect in accordance with the tender specifications & Purchase Order and that material used are in accordance with the latest approved standards and are of good workmanship / quality. Any item or part of item if found to be substandard or not meeting the specified criteria as per inspection carried out at stores. Then in such as event the Supplier / bidder hereby warrants and undertake to replace the same on Duty Delivery Paid (DDP) basis (INCOTERMS 2010) i.e. Free of all cost including but not limited to transportation, Taxes and duties. In case successful bidder / supplier failure to replace the defective item / remove the defect(s), free of cost within the period specified by the Purchaser, the successful bidder / supplier will refund the relevant cost including all other expenses incurred by the purchaser in this regard.

ii) The successful bidder / supplier must confirm that the warranty for non-consumable items will remain valid for 18 months and for consumable items (i.e. Chemical, Battery etc.) will remain valid for 6 months after the goods have been successfully delivered or commissioned.

iii) It is mandatory that the successful bidder / supplier will submit the attached undertaking at Annex-I, duly filled, signed & stamped.

iv) In case where performance guarantee is not applicable, the supplier shall confirm that all supplied goods under the contract / purchase order are new, unused, of most recent or current models and incorporate all recent improvements in design and goods unless and otherwise provided in the contract / purchase order.

v) The Warranty Undertaking being provided by the successful bidder is required to be submitted at least on Rs.200/- Non-judicial Stamp paper and should be duly notarized / attested.

vi) In case of Supply, Installation, Testing & Commissioning, since all these activities are inter-related to each other, therefore, the payment of supplies will be released after successful installation, Testing & Commissioning.

2. Bid Security:

- Bid bond submission (2%) of the bid amount as mentioned in the clause 9 of General Terms & Conditions, to be treated as null & void, however, other contents of clause 9 will remain unchanged. The submission of fixed amount of Bid security is appearing in the Schedule of Requirement/Bid Form.
- All the bidders are advised to furnish fixed bid security (Original Instrument) as per amount appearing in Schedule of Requirement/Bid Form, failing which their bid will be rejected.
- The submission of fixed amount of bid security is also mandatory for all the bids valuing Rs.500,000/- or less.
- The word lowest bidder or the lowest evaluated bid has been substituted to read as **most advantageous bid**.
- Sub-clause 9.2 of the General Terms & Conditions to be treated as null & void, however, other contents of clause 9 will remain unchanged.

3. Method For Submission of Bid Bond (Under Single Stage Two Envelope Bidding Procedure):

In case of Single Stage Two Envelope Tenders the fixed bid bond as per clause#09 of General Terms & Conditions to be placed in the Technical Proposal. However, if the bid bond is placed in the financial proposal will also be considered. Without submission of bid bond (either in Technical proposal or financial proposal) the bid will be rejected.

4. Bid Validity:

All offers shall remain valid up to 120 days from the date of opening of bids and bid bond shall remain valid for 150 days.

5. Declaration / Integrity Pact / Certification: It is required to be submitted by the Successful Bidder on their letterheads after issuance of Purchase Order (PO) or Letter of Intent (LOI), for the value of Rs.10,000,000/- (Ten Million) or above. ANNEXURE-C is a mandatory requirement for successful bidder.

6. Stamp Duty:

The successful Bidder shall provide the copy of challan and revenue stamp, of value at the rate of twenty five (25) paisa per every hundred Rupees or part thereof of the amount of the purchase order, or at the prevailing rate as specified by the Government of Province of Sindh. Further as per Government of Sindh Board of Revenue notification NO.CIS/SWB/BOR/R&T-17/2022-808 dated 08-06-2022 all judicial and non-judicial stamp paper of the denomination of rupee five hundred and above shall be exclusively on e-stamp.

7. Cancellation of Purchase Order

In case the supplier fails to deliver the material within the specified delivery schedule as given in Purchase order (P.O.) and maximum upto 120 days after the expiry of the specified delivery schedule as per Purchase Order, the Purchase Order will be treated automatically as cancelled at supplier's sole risk & cost. However, for the sake of

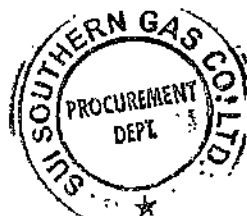

clarity liquidated damages (Clause-27 of General Terms Conditions) and Default by Supplier (Clause-28 of General Terms Conditions) will be treated as given in the General Terms & Conditions of the tender documents.

8. Correct Postal Address.

Bidder are essentially required to provide correct and latest postal, e-mail & web addresses, Phone/cell/fax numbers at the time of purchase of tender documents for effective and timely communication, failing which in event of any non-delivery of information /communication the procuring agency will not be held responsible and bid will be considered as non-responsive.

9. "In case the local agent requires to offer bid from more than one principal / Manufacturers, it is mandatory to purchase separate tender document for each principal / Manufacturer, failing which the bid submitted with the original tender document will only be accepted and the bid with photocopy of tender document will be rejected".

10. "Original counter-slip of token which is issued with original tender document to be attached on the TOP of envelope at the time of bid submission".

11. The Successful Contractor(s) / Consultant(s) shall submit a copy of Professional Tax Certificate with their invoice / Bills failing which the payment will not be released.

12. Blacklisting Mechanism of Suppliers and Contractors and their Local Agent:

Black listing mechanism is attached separately in the tender documents which will become an integral part of Tender Documents and now be followed / enforced in true letter & spirit and supersede the Black listing terms as mentioned in the General Terms & Conditions.

13. Bid Bond & PBG (Performance Bank Guarantee) for Proprietary Tenders

In case of proprietary Tenders, the Bid Bond & Performance Bank Guarantee (PBG) are not required / Applicable.

14. Any Bidder who change / amend the BOQ or Price Schedule (description, Quantity, UOM etc.) will render the bid as conditional bid and will be liable for rejection.

15. Clause 14.1 of General Terms & Conditions is meant for vendorized items processed through negotiated tendering clauses.

16. For open competitive bidding if the most advantageous bidder is new local manufacturer, 10% trial order will be placed and remaining 90% order will be awarded to the next most advantageous bidder at their own quoted rates.

16(a) Bidders awarded a trial order (10% of the complete order) shall, upon successful delivery and satisfactory performance, be allowed to participate in future tenders of the same item; however, until completion of the trial order, they will be declared technically non-compliant by the user department as per the above-mentioned clause in the Special Terms & Conditions. During the currency of the trial order, they will not be issued further POs until the trial order is successfully completed.

17. SSGC will not pay invoices if they are turned in after 6 months of work completion / material delivered.

18. It is mandatory for the bidders to follow all the terms and conditions given in the tender documents without any addition / deletion / amendment and submit the bid accordingly. Therefore, in this context, the bidders are requested not to give their own terms and conditions as it tantamount towards the conditional bid. Otherwise their terms and conditions will not be considered and the Purchase Order / Contract will be awarded based on only as per SSGC tender terms and conditions.

19. The bidders/contractors are required to provide their only one Bank Account number (IBAN number) on the 'FORM-X' attached duly signed & stamped as one time information, which shall be firm (not changeable) for all the future payment transactions.

20. Payment:

The supplier after delivery of goods and its acceptance shall submit invoice to Finance Department of the Company, containing following information i.e.

- (a) Purchase order No. & date
- (b) Items
- (c) Quantity
- (d) Price
- (e) Invoice value
- (f) Point of delivery
- (g) Delivery challan indicating delivery date, etc.
- (h) Supplier(s) are required to submit signed and stamp acknowledgement slip, Sales Tax return, Annex "C" & Annex "I" (whichever applicable) in which Sales Tax (of relevant Sales Tax invoice) is paid.

Payment will be made within 30 days of completion of stated requirements.

21. **Joint Ventures:** In the event that the bidder is bidding as a Joint Venture, the Company will require the joint venture agreement duly executed by the parties to the Joint Venture to be submitted with the bid. The joint venture parties shall also furnish an undertaking to be jointly and severally liable for all liabilities arising out

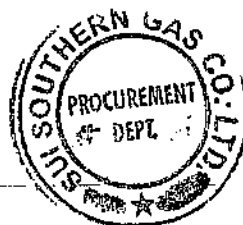

of obligation under the Purchase Order / Contract. The Joint Venture agreement of the parties must specify share of each partner and name of the lead partner along with their registration with the FBR, SST and BST as the case may be failure to specify these two narrations the joint venture agreement will not be entertained.

22. **Bank Guarantee (Bid Bond Guarantee/Performance Bank Guarantee) will be made on Non-Judicial stamp paper at the prevailing rate as specified by the respective Provinces. Further the bidder/contractor submitting the Bid Bond guarantee/Performance Bond guarantee being prepared by the State Bank's schedule banks should ensure that there should be no deletion/insertion/alteration/modification of any terms in the Bid Bond/PBG guarantee format as given in the tender document or else bid will be liable for rejection.**

23. **In case the insurance policy submitted by the contractor is expired during the execution of job, it is the responsibility of the user department to coordinate with the contractor to get it renewed/updated till the period the job is completed/commissioned.**

In case the job is not completed within the given time as per tender terms and the insurance policy submitted by the contractor expires, the contractor is liable to get this insurance policy renewed / updated immediately till the period of the job is completed / commissioned as per tender terms failing which the contractor will be responsible for any loss to SSGC.

24. **Bidders can quote their rates on both i.e. Schedule of Requirement/Bid Form as well as Bill of Quantity (BoQ).**

25. **Company reserve the right to award the Purchase Order /LOI to the most advantageous bidder.**

26. **As per SRO 592(I)/2022 of PPRA Regulations, for Procurement Contracts/Purchase Orders worth of Rs. 50 million and above, bidders/contractors are required to submit the Beneficial Owner's Information for Public Procurement Contracts/Purchase Orders (Annexure-1).**

27. Fixed Bid Security – Alternative Bid

A bidder cannot submit two bids/offers with a single fixed bid security/pay order. However, the alternative bids/offers with separate fixed bid security/pay order can be accepted, failing which the bids will be liable for rejection. In case the bidder quote different make/brands/model that will also be considered as an Alternative bid/offer and require to submit separate Bid bond for each make/brand/model.

28. Bidder will be blacklisted and henceforth cross debarred for participating in respective category of Public Procurement proceedings for a period of (not more than) six months, if fail to abide with a bid securing declaration (which is an integral part of tender document), however, without indulging in corrupt and fraudulent practices, if in breach of obligation(s) under the Bid conditions:

a) The bidder have withdrawn or modified their bid during the period of bid validity as specified in the tender terms.

b) Having been notified of the acceptance of bid by procuring agency during the period of bid validity (i) failure to sign the contract or accept purchase order (ii) fail or refuse to furnish the performance security or to comply with any other condition as mentioned in the tender document.

29. Wherever the "Rate Only" is mentioned (either on BOQ or anywhere in tender documents) the same shall only be applicable not exceeding 15% of the original procurement for the same items as given in the BOQ for package basis. In case the requirement is on item wise basis (not package basis) then not exceeding 15% of the original Procurement for the same items (on item wise basis) as given in the BOQ.

30. **Lots:** In case when the tender is floated on LOT basis, following clauses to be applied:

a) The bidder(s) are essentially / mandatorily required to submit fixed bid bond as mentioned in the bid form/BOQ/Invitation to Bid. Separate fixed bid bond to be submitted against each individual LOT and its validity to be 150 days at the time of opening of technical proposal.

b) Evaluation for each LOT will be carried out separately. Each LOT will be awarded separately.

31. Subsequent to the issuance of Purchase Order/LOI, successful bidder has to submit 10% Performance Bank Guarantee of the Purchase Order/LOI value unless & until specified in the Tender Documents. Clause# 16.1.5 mentioned in General Terms & Conditions to be treated as null & void.

32. Redressal of Grievances And Settlement of Disputes:

- Any bidder feeling aggrieved by any act of the procuring agency after the submission of his bid may lodge a written complaint concerning his grievances within seven days

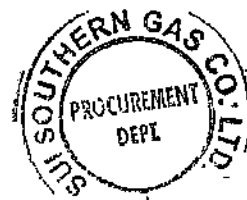

of announcement of the technical evaluation report and five days after issuance of final evaluation report.

- In case, the complaint is filed against the technical evaluation report, the GRC shall suspend the procurement proceedings.
- In case, the complaint is filed after the issuance of final evaluation report, the complainant cannot raise any objection on technical evaluation of the report. Provided that the complainant may raise the objection on any part of the final evaluation report in case where single stage single envelope bidding procedure is adopted.

33. The sub clauses 33.2, 33.4 & 33.5 of clause 33 of General Terms & Conditions to be treated as null & void:

34. All the bidders are allowed to participate in the subject procurement without regard to nationality/origin, except bidders of some nationality/origin, prohibited in accordance with policy of the Federal Government. Following countries are ineligible to participate in the procurement process:

- India
- Israel

35. In Open Competitive Bidding Procedure where the quoted price is less than Rs. 500,000/- the Bid Bond will be retained in lieu of PBG.

36. In case the Bid Bond is not required, the bidder must submit the Form of Bid-Securing Declaration attached with the Tender Document else the Bid will be liable for rejection.

37. All Tenders floated through EPADS are to be governed by S.R.O. 296(I)/2023 dated: March 8, 2023 "E-Pak-Procurement Regulations 2023". In case of any conflict between SSGC Tender Terms / Instructions to Bidders and the PPRA EPADS Rules, the S.R.O. 296(I)/2023 will prevail.

38. **Samples:**

When sample submission is required. Suppliers/bidders must submit samples:

- a) Along with the bid, if stated in the tender documents.
- b) Within the time specified in the tender.
- c) Upon request from the User Department for technical evaluation through official email/ letters.

SAMPLE SUBMISSION LOCATION/DEPARTMENT:

All samples must be submitted to the Procurement Department - Tender Room, SSGC Head Office with Duly filled-in form "Y" attached in the tender document. Samples submitted other than the Procurement Department - Tender Room, SSGC Head Office will not be considered/accepted.

The supplier/bidder must:

- Fill in all required details (e.g., Tender No., Bidder Name, and Sample Description).
- Attach supporting documents (if required).
- Submit the completed Form-Y along with the sample.

In absence of any of the above stated requirements the Samples will not be considered/accepted.



Sui Southern Gas Company Limited

Schedule of Requirement & Bid Form

SECTION - 3

RFQ Number		SSGC/LP/EPADS/PT/2157168		Open Bidding Date		19-MAY-26 14:57	
Document Number		2157168		Close Bidding Date		16-JUN-26 10:30	
S#	Item Code	Item Description	Unit	Quantity	Make / Brand	Unit Price Inclusive of all discount (if any) & Exclusive of GST	Value PKR
1	2	3	4	5		6	7 = 5 x 6
1	SC212518	HVAC WORKS INSTALLATION, TESTING & COMMISSIONING OF HVAC SYSTEM FOR SSGC HEAD OFFICE BUILDING (AS PER BOQ)	Job	1			
2	CC212519	HVAC WORKS SUPPLY OF MATERIALS OR REQUIRED FOR THE INSTALLATION OF HVAC SYSTEM FOR SSGC HEAD OFFICE BUILDING (AS PER BOQ)	Lot	1			
Total Fix Bid Bond Amount PKR: 500,000							

NOTE:

1. The quoted unit price and corresponding total amount shall be inclusive of all duties and taxes and discount (if any) except General Sales Tax (GST). Sales Tax will be applicable as per GST act and subsequent amendments of time to time. GST will be reimbursed to manufacturer and importers only, subject to production of paid invoice.
2. Bidders are essentially required to quote on bid form. Rates quoted on other than bid form will not be entertained.
3. Any queries / complaints regarding subject tender enquiry shall be addressed to GM(P) / DGM(P) in writing
4. **EVALUATION CRITERIA :** Order will be placed on the Lowest Technically / Commercially Compliant bidder (s), unless specified otherwise.
5. In case when bidder submit alternate bids, a separate Bid Bond for each bid is required. All the bidders are advised to furnish fixed bid security amount appearing in price schedule/BOQ otherwise bid will be liable for rejection.
The submission of fixed amount of bid security is also mandatory for all the bids valuing RS.500,000/- or less.
6. Any Bidder who change/amend the BOQ or Price Schedule (Description, Quantity, UOM etc.) will render the bid as conditional bid and will be liable for rejection.
7. Bid bond submission (2%) of the bid amount as mentioned in the clause 9 of General Terms & Conditions, to be treated as null & void, however, other contents of clause 9 will remain unchanged.
8. All offers shall remain valid up to 120 days from the date of opening of bids and bid bond shall remain valid for 150 days.
9. Special terms & conditions and warranty guaranty attached at annexure 01.

Signature : _____
 Person Name : _____
 Company's Name : _____
 Date : _____

HASSAN ANSARI
 Deputy Manager (Procurement)
 Sui Southern Gas Co. Ltd.

End of page, any entry beyond this line would be invalid

Completion Period: Time for completion shall be 180 days. However, letter to proceed (LTP) with timeline would be separately issued for each stage and LD shall apply individually for each component.

Note:

- Tender is on Complete Package Basis.
- PEC Certificate in Category C-4 or above with specialization code in ME01.
- HVAC OEM Certified / Authorized local resource for Installation, Commissioning, Operation & Maintenance Services (any reputable chillers manufacturer).

Under Single Stage Two Envelope Bidding Procedure

Section 3

SSGCL HEAD OFFICE BUILDING, KARACHI

BIDDING DOCUMENT FOR THE SERVICES REQUIRED FOR INSTALLATION & COMMISSIONING OF HVAC SYSTEM



01	20/04/2026	Tender	FND-1890-TD-H-XX-PKG-001	DA	FA	Tender for HVAC Works
----	------------	--------	--------------------------	----	----	-----------------------

CLIENT
Sui Southern Gas Company Ltd.
 ST-4/B, Hassan Square Flyover,
 Block-14, Gulshan-e-Iqbal,
 Karachi-75300.

CONSULTANT
Fahim, Nanji & deSouza (Pvt.) Ltd.
Consulting Engineers
 4th Floor, ILACO House, State Life Building-5,
 Abdullah Haroon Road, Saddar,
 Karachi-74400.
 Phone (92-21) 3563-7878-82
 Fax (92-21) 3521-1634
 E-mail: mech.dpr@fnd.com.pk
 Web: www.fnd.com.pk

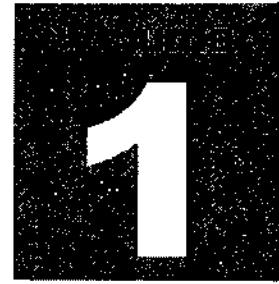

Table of Contents

	NO. OF PAGES
DIVISION 1: CONDITIONS OF CONTRACT	
General Scope of Works	2
Civil Scope of Works	1
Scope of work for Control Room (Rev-003).....	3
Eligibility Criteria.....	1
SSGC Conditions of Contract.....	106
Special Terms and Conditions LWT (Rev-006)	1
DIVISION 2: TECHNICAL SPECIFICATIONS	
23 05 01 Basic Mechanical Requirements.....	23
23 05 02 Basic Mechanical Materials & Methods	9
23 05 10 Equipment Installation.....	1
23 05 11 Pipe Welding.....	2
23 05 13 Electric Motors.....	4
23 05 19 Meters & Gauges	2
23 05 23 Valves & Strainers	3
23 05 29 Supports & Anchors.....	3
23 05 48 Vibration Isolation & Control	4
23 05 49 Seismic Restraints.....	14
23 05 50 Painting and Coating	3
23 05 53 Mechanical Identification	2
23 05 93 Cleaning, Testing, Adjusting & Balancing	2
23 05 94 Test Run	1
23 07 19 Piping Insulation.....	2
23 09 20 Automatic Control System	4
23 21 13 Hydronic Piping & Specialties.....	4
23 21 30 Centrifugal Pumps.....	10
23 25 17 Water Treatment System For Condenser Water Circuit (Large System).....	3
23 31 13 Duct Works & Accessories	10
23 34 17 Plug Fan.....	2
23 41 10 Air Filters	3
23 64 17 Water Cooled Centrifugal Chillers-Variable Speed-134a.....	17
23 73 10 Air Handling Units	10



**SSGCL HEAD OFFICE BUILDING, KARACHI
HVAC WORKS**

23 86 20	Flow Balancing Valves.....	1
23 86 35	Air Vents.....	1
23 87 15	Motor Control Centres.....	5
23 87 20	Variable Frequency Drives.....	3
23 89 10	Tools & Instruments (Electric Chillers).....	1
26 05 19	Wires & Cables.....	7
26 05 33	Raceways/Boxes.....	5
23 90 10	List of Approved Manufacturers (HVAC Works).....	3

DIVISION 3: EQUIPMENT DATA SHEETS

1890-23 07 13	Duct Work Insulation.....	1
1890-23 07 19	Piping Insulation.....	1
1890-23 09 10	Building Management Systems.....	3
1890-23 21 13	Hydronic Piping & Specialities.....	1
1890-23 64 17	Electric Operated Water Cooled Chiller (Owner Furnished).....	2
1890-23 73 10	Air Handling Units.....	1
1890-23 87 15	Motor Control Centres.....	5
1890-23 87 20	Variable Frequency Drives (VFD's).....	1
1890-00 00 00	Condenser Pump (from SSGC).....	2
1890-00 00 00	Cooling Coils (from SSGC).....	3

DIVISION 4: BILL OF QUANTITIES

1.	Pricing Preambles & Instructions.....	2
2.	Summary of Bill of Quantities.....	1
3.	Bill of Quantities.....	8

DIVISION 5: DRAWINGS

Tender Drawings.....	A/2
----------------------	-----

Anty





**SSGCL HEAD OFFICE BUILDING,
KARACHI**

Conditions of Contract

HVAC Works

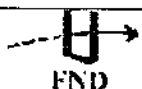
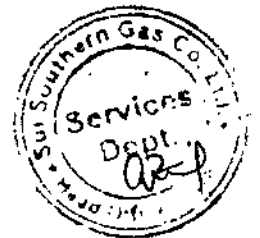

Fahim, Nanji & deSouza (Pvt.) Ltd.
Consulting Engineers



GENERAL SCOPE OF WORKS

PROJECT NO : 1890
PROJECT TITLE : SSGCL HEAD OFFICE BUILDING, KARACHI
DATED : 20TH APRIL, 2026

GENERAL:

SSGC'S Head Office Building situated at Gulshan-e-Iqbal Karachi opposite to Expo Centre. Building was constructed in year 2000 and since then air conditioned by 02 x 430TR Mitsubishi brand Direct Gas Fired Absorption Chiller (DGFAAC).

SSGC is in the process of revamping the HVAC infrastructure. SSGCL intends to install and integrate two (02) water-cooled electrical centrifugal chillers, with the existing gas absorption chillers. In this regard, SSGCL seeks to engage qualified HVAC bidders/contractors possessing extensive experience in the installation, testing, and commissioning of HVAC systems and associated accessories.

1. GENERAL SCOPE OF WORKS

The scope of work shall be as follows but not limited to:

- a) Development of shop drawings and furnishing material submittal documents as per international standards up to the satisfaction of Engineer/ Company.
- b) Installation of 02 Nos, Water cooler electrical centrifugal chillers having capacity of 375RT and integration with the existing installed Gas absorption chillers.
- c) Transportation of owner furnished Water Cooled Electrical operated Chillers from the site store to the SSGCL basement designated area.
- d) Dismantling of the existing 01 No. AHU installed in the basement, installation of owner furnished AHU and assistance in testing, and commissioning of AHU, in accordance with the attached specifications and data sheet.
- e) Integration of new Electrical power supply system with the existing installed electrical network system for the safe and smooth operation of Chillers.
- f) Supply, Installation, Testing and commissioning of variable frequency drives as per BOQ and Specifications
- g) Complete all allied electrical works as per the items listed in the BOQ, Specification and data sheets.
- h) Complete all allied Mechanical works as per the items listed in the BOQ, Specification and data sheets.
- i) Complete all the civil associated works for the entire completion of the project not limited to Foundation work for chillers, relocating of existing operator's room in plant room as per SSGC instruction and construction of new observation/ operator's room as per tender specification and drawings etc.
- j) Providing warranties and guarantees as specified.
- k) Supplying 5 copies of complete operation & maintenance manual in both hard (bound) and soft (electronic) formats.



Fahim, Nanji & deSouza (Pvt.) Ltd.
Consulting Engineers

General Scope of Works
Section 200 - 1



GENERAL SCOPE OF WORKS

PROJECT NO : 1890
PROJECT TITLE : SSGCL HEAD OFFICE BUILDING, KARACHI
DATED : 20TH APRIL, 2026

- o) Provide operation and maintenance training for a suitable period as determined by the manufacturer and approved by the Client/Consultant but not limited to:
- Sequence of operations of Chillers etc.
 - Maintenance of the newly installed integrated equipment.
 - Operations and maintenance of newly integrated piping and plumbing network.
 - Queue of Operations and maintenance of newly integrated electrical system.
 - Operations of newly integrated BMS system.
- m) Above training shall be carried out site and at a reputable venue within Karachi premises.
- n) Any damage to the existing building infrastructure, including but not limited to floor tiles, walls, ceilings, finishes, or services, caused during the transportation and execution of work shall be repaired or reinstated by the Contractor at its own cost, to the satisfaction of the SSGC/Engineer.

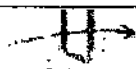

F.N.S.

Fahim, Nanji & deSouza (Pvt.) Ltd.
Consulting Engineers

General Scope of Works
Section: 200 -- 2



Civil / Mechanical Works Associated with Transportation of HVAC Equipment

Transportation of owner furnished Water Cooled Electrical operated Chillers from the SSGC's Karachi Terminal store to the SSGCL designated area for the safe lowering including AHU, supplied MCC Panels etc into the basement at the SSGCL Head Office and placing it in the pre-defined area/spot. Throughout the execution period, normal office operations—including air-conditioning—shall remain uninterrupted.

The scope of work includes, but is not limited to, the following:

- a. Inspection of existing access routes and locations for the safe transportation of Chillers/AHU/MCC electrical panels to the basement of SSGCL Head Office.
- b. Arrangement of all resources material and machinery (crane, lifter) will be under contractor scope.
- c. Temporary removal and subsequent reinstallation of any obstructions encountered along the transportation path—such as cable trays, piping, or similar services—shall be the responsibility of the contractor.
- d. Shifting and positioning of the Chiller, AHU, and MCC Panels at the designated installation locations through rigging, using a certified and experienced rigging team.
- e. The contractor shall ensure that removal of any obstruction does not affect or disrupt any operational or live systems at any stage of the work.
- f. Any damage to the existing building infrastructure, including but not limited to floor tiles, walls, ceilings, finishes, or services, caused during the transportation and execution of work shall be repaired or reinstated by the Contractor at its own cost, to the satisfaction of the SSGC/Engineer.
- g. Following requisites are mandatory before starting of material transportation, lifting and rigging job.
 - Certifications of crane and valid license of crane operator from 3rd party.
 - Rigging plan / methodology is to be submitted 20 days in advance before starting transportation and lifting work.
 - Valid 3rd party inspection certificate of tools / equipment's to be used in transportation and rigging job.
 - The lifting, shifting, and lowering of the chillers up to the designated foundation level shall be carried out under the supervision of a third-party certified lifting engineer engaged by the Contractor.



SCOPE OF WORK

1.0 General

The contractor shall furnish all labor, materials, equipment, and supervision to construct a freestanding observation / control room within the basement @ SSGC Head Office Karachi for HVAC plant room. The structure shall utilize the existing concrete pillar as one corner support, with three custom aluminum box-section pillars completing the structural frame. The design shall provide maximum visual coverage, thermal insulation, acoustic performance (minimum STC 35), and fire resistance.

2.0 Structural Framework

Pillar Integration: The room's footprint incorporates one existing concrete pillar (2.5' x 2.5'). This pillar shall serve as the primary structural support for that corner. The contractor shall securely attach the roof header and wall framing to the pillar using non-combustible anchors (expansion bolts or chemical anchors) with appropriate fire-rated sealants.

Aluminum Pillars (Three Corners): For the remaining three corners, supply and install 4" x 4" (101.6 mm x 101.6 mm) extruded aluminum hollow box sections, wall thickness minimum 3 mm (6063-T6 or equivalent). These pillars shall be anchored to the concrete floor slab with base plates and epoxy-grouted anchor bolts. They shall extend full height (8 ft) to support the roof structure.

Upper Framing: Connect the three aluminum pillars and the existing concrete pillar via a perimeter header system of aluminum C-channels or custom box beams to form a rigid ring beam that supports the roof and provides fixing for the glazing and knee wall panels.

3.0 Knee Wall (3 ft High Base)

Construction: The lower 3 ft of the walls shall be constructed using fire-retardant (FR) sandwich panels (mineral wool or PIR core, 50 mm thick) mounted on the aluminum sub-frame. On the side of the concrete pillar, the panels shall be mechanically fixed or bonded to the pillar surface using fire-rated adhesives and mechanical fasteners to ensure a continuous thermal and acoustic barrier.

4.0 Glazing (Above Knee Wall)

Type: Double-glazed units (DGU) with acoustic laminated glass. Minimum 24 mm overall thickness (e.g., 6.38 mm laminated + 12 mm air gap + 6 mm tempered). Provide a minimum STC 40 rating.

Framing: Glazing shall be captured in aluminum pressure plates or structural silicone, ensuring a continuous seal around the perimeter. The glass shall extend from the top of the knee wall to the underside of the roof header.

Corner Treatment: At the concrete pillar corner, the glazing shall be trimmed to fit precisely against the pillar face, with neoprene gaskets and sealant to maintain acoustics and aesthetics.

Control Room: Observation Layout

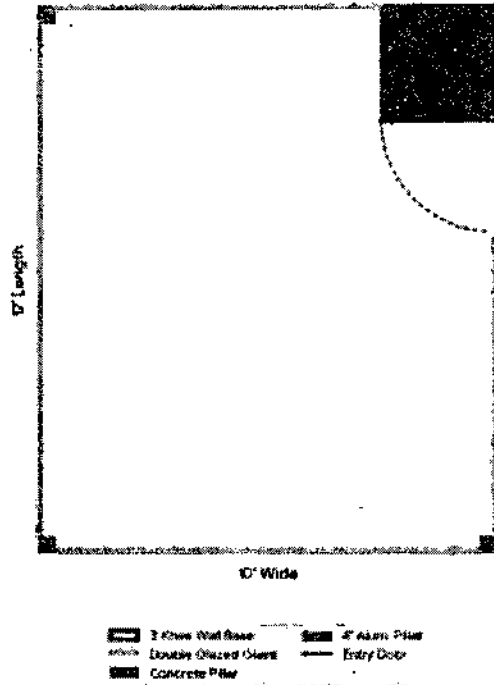

5.0 Roof System

Structure: The roof shall be supported by the three 4"x4" aluminum pillars and the concrete pillar. An aluminum roof frame (C-section or tube grid) shall be fabricated and bolted to the pillars.

Roof Panel: Install fire-retardant aluminum composite panels with a glass fiber reinforced polymer (GFRP) core, or a similar certified fire-retardant roofing panel (Class A / A2-s1,d0). Panels shall be minimum 40 mm thick, with sealed joints, and include a slight pitch (minimum 1:60) for drainage if the basement environment requires condensation control.

Insulation: The roof assembly shall provide thermal insulation ($U\text{-value} \leq 0.45 \text{ W/m}^2\text{K}$) and be non-combustible to comply with machinery room fire codes.

6.0 Door

Type: One double-glazed acoustic aluminum door, 2.5' wide x 7' high, positioned flush against the face of the concrete pillar to maximize visual coverage. Include an automatic drop seal, heavy-duty hinges (3), and a mortise lock suitable for plant room environments.

Integration: The door frame shall be integrated into the aluminum framing system with thermal breaks and acoustic seals.

7.0 Fire Retardancy & Sealing

All aluminum structural members (pillars, headers, sub-frame) shall be coated with intumescent paint to achieve a minimum 30-minute fire resistance rating.

All penetrations (for electrical, HVAC, etc.) shall be fire-stopped with approved intumescent sealants and collars.

Joints between the new structure and the existing concrete pillar, floor, and walls shall be sealed with fire-rated acoustic caulk.

8.0 Finishes & MEP Coordination

Floor: Provide self-leveling compound and anti-static / epoxy finish over the existing slab, or a raised access floor as required by the control equipment.

MEP: Coordinate sleeves and cutouts for lighting, power, data, and HVAC (fresh air / mini-split) penetrations. All such openings shall be framed and sealed to maintain acoustic and fire integrity.

Tender Instruction Addendum

Bidders are required to:

1. Visit the site to verify the exact dimensions, condition of the concrete pillar, floor flatness, and basement access constraints.
2. Submit a method statement detailing how they will achieve the specified acoustic (STC \geq 40) and fire-rating (30-min structural, Class A roof) performance.
3. Provide material datasheets for the fire-retardant roof panels, glass units, and intumescent coating with their bid.

02/3



Electrical & Lighting Layout

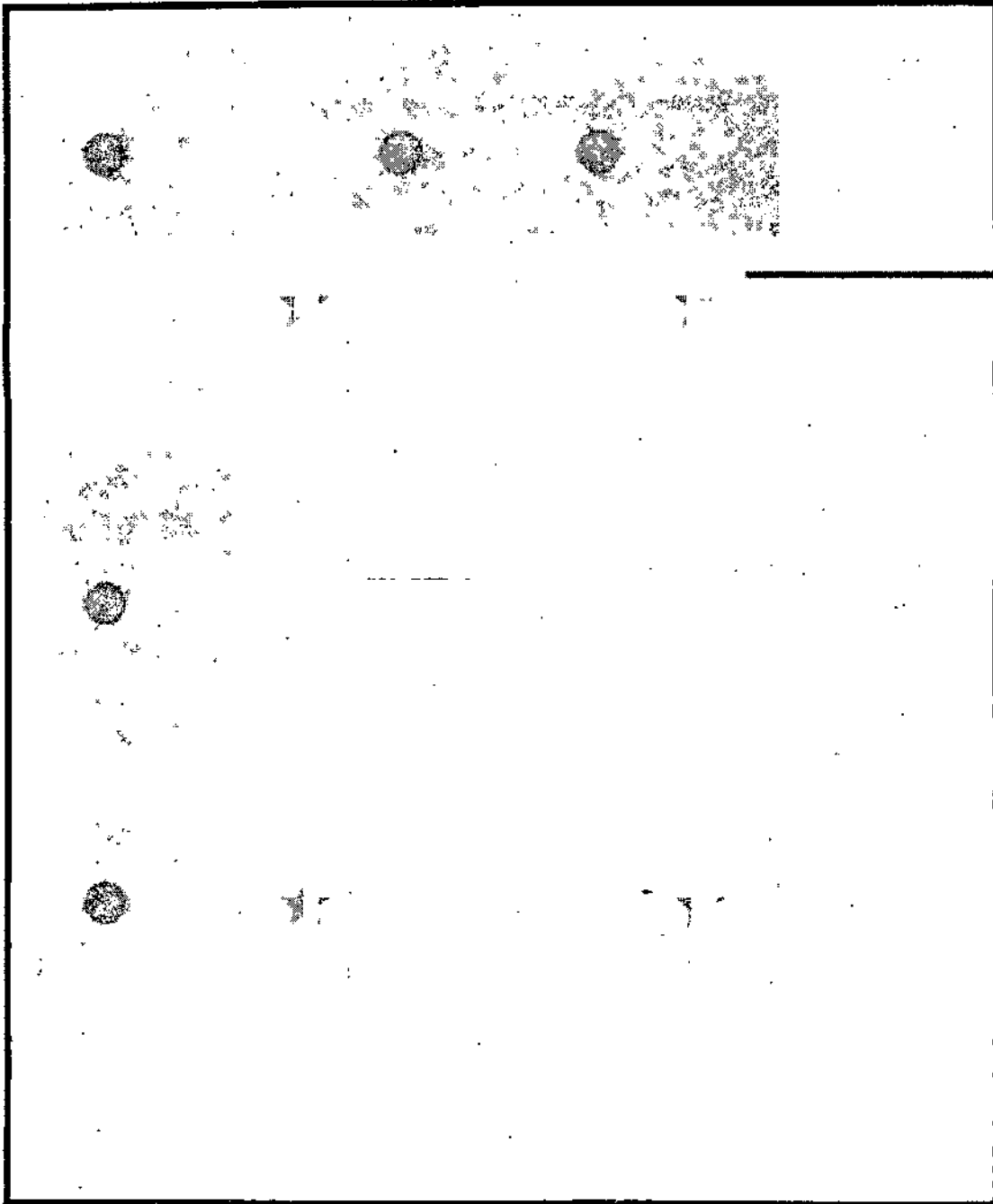

■ Power Outlet

○ Dim. Indirect LED

Handwritten signature and initials, possibly "RJP", in a circular stamp area.



TECHNICAL CRITERIA FOR THE EVALUATION OF SUPPLY, INSTALLATION, TESTING & COMMISSIONING OF HVAC WORKS

S.NO	DESCRIPTION	STANDARD POINTS	MAX. POINTS	OBTAINED POINTS
1.0	MANDATORY			
1	PEC Certificate in Category C-4 or above with specialization code in ME01. ✓	MANDATORY	MANDATORY	
2	Tax Payers Registration Certificate (FBR) ✓			
2.0	FINANCIAL SOUNDNESS			
i	Working Capital in Last 5 years - upto 50 million			
a	>50 million	15	15	✓
b	> 35 million	10		
c	> 25 million	5		
3.0	EXPERIENCE RECORD			
i	NOS. OF YEAR ESTABLISHING COMPANY IN PAKISTAN ✓			
a	>10 Years	10	10	
b	5 to <10 Years	7		
c	< 5 Years	5		
ii	NATURE OF COMPANY			
a	Limited company / Joint Venture ✓	10	10	
b	Partnership	7		
c	Proprietorship	5		
iii	HVAC Projects of similar nature and complexity completed in last 5 years:			
a	HVAC accumulated capacity of >1000 TR Chillers.	15	15	
b	HVAC accumulated capacity of >500 TR Chillers.	10		
c	HVAC accumulated capacity of >250 TR Chillers.	5		
iv	Electrical/Mechanical/Piping Integration Projects of similar nature and complexity in hand:			
a	Projects worth > 50 Million.	15	15	
b	Projects worth > 25 Million.	10		
c	Projects worth > 10 Million.	5		
4.0	PERSONAL CAPABILITIES			
i	OEM Certified Resource			
a	HVAC OEM certified / Authorized local resource for installation, Commissioning, Operation, & Maintenance services (any reputable chillers manufacturer)	5	5	
ii	Enrolled Engineers Registered with PEC			
a	Project team lead with 15 years experience and at least project execution experience of either 5 years or 5 projects of same nature and capacity.	10	20	
b	Mechanical Engineer with at least Eight (8) years Experience (1.No)	5		
c	Electrical / Electronics Engineer with at least Five (5) years Experience (1.No)	5		
iii	Diploma Engineers in Employment of the Firm			
a	HVAC Supervisor with at least 8 years experience (No.2)	5	10	
b	Electrical / Electronics Supervisor with at least 8 years experience	5		
TOTAL POINTS			100	

Note:

1. Minimum 75 marks are required to qualify
2. Bidders must acquire the minimum marks in Financial soundness and Personal capabilities mentioned against each sub-category to qualify for Financial evaluation
3. Documentary evidence to be attached along with **FORMS** placed at the end of tender documents otherwise marks will not be awarded
4. Resume / CV of concerned executives / staffs.

Service Dept



SPECIAL TERMS AND CONIDITIONS

PROJECT NO : 1890
 PROJECT TITLE : SSGCL HEAD OFFICE BUILDING, KARACHI
 DATED : 20TH APRIL, 2026

SPECIAL TERMS & CONDITIONS

The conditions set forth herein under Special Terms and Conditions to the Tender and where these conditions conflict with provisions or requirement set forth elsewhere in the contract documents these conditions shall govern.

Reference Clause	Clause Description	Contract Stipulations	
	Completion Period	Time for completion shall be 180 days. However, letter to proceed (LTP) with timeline would be separately issued for each stage and LD shall apply individually for each component.	
	Component breakdown timelines	Lot 1 /LTP-1 30 Days Pre-shipment of chiller a) Mobilization b) Civil and allied Works	} 30 Days } 120 Days } 30 Days } 180 Days 0.1% of Contract Price for each day of delay. Max. 10% of Contract Price
	Lot 2 /LTP-2 Phase-2 120 Days	Post-shipment of chiller a) Transportation & Logistics b) Mechanical/ Plumbing Works c) Electrical Works d) Testing and Commissioning	
	Lot 3/LTP-3 Phase-3 30 Days	Post Commissioning Test Run	
	Lot 1/LTP-1-Conjunction with Phase-1 180 Days	Provision for Supply, Installation and commissioning of items and spares inventory as detailed in the BOQ (Sediment separator, Cooling coils, and Condenser Pumps and Motor etc.) after LOI Acceptance & initial LTP.	
	Performance Bond	5% (Five Percent) of Contract value	
	Retention Money	5%(Five Percent) of all payments made to the Contractor	
	Mode of Payment	1. Project execution based on the actual work carried out cumulative progress of 25% of the total job, vetted, and submitted by the consultant 2. Project execution based on the actual work carried out cumulative progress of 50%, vetted, and submitted by the consultant. 3. Project execution based on the actual work carried out cumulative progress of 75% of the total job, vetted, and submitted by the consultant 4. Project execution Completion, vetted and submitted by the consultant. 5. Site acceptance test, final commissioning and handover to SSGC	20% 40% 60% 80% 100%
	Maintenance Services	Comprehensive services for 1 Year after Taking over certificate issued by the SSGC	
	Warranty Period	1 Year after Taking over certificate issued by the SSGC	
	Liquidated Damages	0.1% of Contract Price for each day of delay. Max. 10% of Contract Price	



Fahim, Nanji & deSouza (Pvt.) Ltd.
 Consulting Engineers

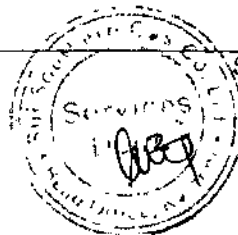

Special Terms & Conditions
 Section 300 - 1





**SSGCL HEAD OFFICE BUILDING,
KARACHI**

Technical Specifications

HVAC Works

Handwritten signature or initials



Fahim, Nanji & deSouza (Pvt.) Ltd.
Consulting Engineers



SPECIFICATIONS

PROJECT NO : 1890
PROJECT TITLE : SSGCL HEAD OFFICE BUILDING, KARACHI
DATED : 20TH APRIL, 2026

BASIC MECHANICAL REQUIREMENTS

1. Related Documents:

Drawings and general provisions of Contract, including General and Special Conditions apply to this Section.

2. Instructions to Tenderers:

- a) The Specifications & Drawings make reference to certain Standard Specifications and also to certain manufacturers and equipment model numbers. The object of these references is to ensure that the equipment and materials offered by the Tenderers and supplied by the Contractor are in accordance with the required standard of quality, workmanship and capacities, etc. The object is not to limit the selection of equipment to a particular manufacturer unless specifically mentioned in the tender documents that a particular equipment and/or material is to be supplied.
- b) It is clarified that the equipment and the materials complying with various standards and of manufacturers other than mentioned in the tender documents shall be acceptable provided they meet the required capacities as specified and meet the intent of the specifications regarding quality and workmanship.
- c) In case there is any deviation between any item or material offered by the Tenderer from the tender specifications and drawings, the Tenderer shall clearly draw attention to all such deviations and no such item or material shall be supplied by the Contractor without prior written approval of the Engineer/Company.
- d) These Specifications and accompanying Drawings are to be considered as supplementing each other and as such are intended to serve jointly as the basis upon which the Contractor shall establish a Contract Price, and upon which he shall base the performance of the required work.
- e) It is the intent of these Specifications and Drawings to call for finished work, tested, complete, and ready for operation.
- f) These Drawings and Specifications are presented to the Tenderer with the understanding that he is an expert and is competent in the preparation of Contact Bid Prices on the basis of information such as is contained in these documents, which do not include assurance as to their complete accuracy and validity, in all details, and which may depend, for proper execution, upon interpretation by the Engineer/Company. and other Authorities, during the course of construction.
- g) For the above reasons, the Tenderer shall understand that his submission of an unqualified proposal commits him to perform all work expressed and implied in the Drawings and Specifications without additional compensation. He shall further understand that such submission commits him without extra compensation, and within the scope of the Contract, to the following:
 - i) To provide, if required by the Engineer/ Company., the items or arrangements of greater quantity, better quality, or higher cost in the event that a disagreement with regard to; such items occurs between the drawings and specifications, or within one.
 - ii) To provide any small items of work not specifically called for, but required to complete the intended installations.
 - iii) To co-ordinate his work or adjust the same so that conflicts in space do not occur with other trades involved at the project.
 - iv) To coordinate his work or adjust the same to suit site or any other existing conditions.



SPECIFICATIONS

PROJECT NO : 1890
PROJECT TITLE : SSGCL HEAD OFFICE BUILDING, KARACHI
DATED : 20TH APRIL, 2026

3. Design Life of Equipment:

The design life of all equipment and material shall be a minimum of 25 years. Bidder shall identify all equipment and material that has a lower design life and shall indicate the proposed design life in his bid, and this shall be subject to approval by the Engineer.

4. Standards to be kept on Site:

The Contractor shall maintain at his site office a hard-copy of all standards that are referenced in these specifications. The Contractor shall submit to the Engineer/ Company, and obtain approval on a list of all standards that he is required to maintain in his site office. The cost of maintain these standards is assumed to be covered in the overall contract price.

5. Interpretation of the Drawings & Specifications:

- a) Except where modified by a specific notation to the contrary, it shall be understood that the indication and/or description of any item, in the drawings or specifications or both, carries with it the instructions to furnish and install the item, regardless of whether or not this instruction is explicitly stated as part of the indication or description.
- b) It shall be understood that the specifications and drawings are complimentary and are to be taken together for a complete interpretation of the work. Exceptions are that notes on the drawings, which refer to an individual element of work, take precedence over the specifications where they conflict with the same.
- c) No exclusions from, or limitation, in the language used in the Drawings or Specifications shall be interpreted as meaning that the appurtenances or accessories necessary to complete any required system or item of equipment are omitted.
- d) The necessary Drawings utilise symbols and schematic diagrams to indicate various items of work. Neither of these have any dimensional significance nor do they delineate every item required for the intended installations. The work shall be installed in accordance with the diagrammatic intent expressed on the mechanical drawings, and in conformity with the dimensions indicated on final Architectural and Structural working Drawings and on equipment shop drawings.
- e) No interpretation shall be made from the limitations of symbols and diagrams that any elements necessary for complete work are excluded.
- f) Certain details appear on the Drawings which are specific with regard to the dimensions and positioning of the work. These details are intended only for the purpose of establishing general feasibility. They do not obviate field co-ordination for the indicated work.
- g) Information as to the general construction not evident in this specifications and drawings shall be derived from structural & architectural drawings and specifications.

6. Execution of Works:

6.1 Program of Works

The Contractor shall submit to the Engineer/ Company, a detailed Program of Works within 2 weeks from the acceptance of his tender showing the intended method, stages and order of work execution in coordination with the building construction Program, together with the duration he estimated for each and every stage of the Works. The Program shall include at least the following:

- a. Dates for submission of shop drawings and technical submittals;
- b. Dates for the placement of orders for equipment and materials;
- c. Expected completion dates for builder's works, i.e. when work site needs to be ready;



SPECIFICATIONS

PROJECT NO : 1890
PROJECT TITLE : SSGCL HEAD OFFICE BUILDING, KARACHI
DATED : 20TH APRIL, 2026

- d. Delivery dates of equipment and materials to Site;
- e. Dates of commencement and completion of every stage of the Works in line with the building construction Program, i.e. each floor level and/or zone area;
- f. Dates of documents/drawings submissions to relevant Government departments to obtain the necessary approvals;
- g. Dates of requirement of temporary facilities necessary for testing & commissioning, e.g. electricity supply, water and town gas;
- h. Dates of completion, testing and commissioning; and
- i. Short term Programs showing the detailed work schedules of coming weeks and months shall also be provided to the Engineer/Company. Programs shall be regularly updated to reflect the actual progress and to meet the Contractor's obligations under the Contract.

In addition, detailed submission schedules for installation drawings, equipment and testing and commissioning shall be submitted to the Engineer/ Company for approval. The formats and information to be included in the schedules shall be as required by the Engineer/ Company.

6.2 Builder's Work

The builder's work in connection with mechanical equipment rooms construction will be carried out as part of the building works by the Building Contractor at the expense of the Company Representative. The Contractor shall submit full details of such requirements with all details for openings required to be kept for movement of equipment, and for electrical and mechanical services, within a reasonable time to the Engineer/ Company for approval, so that due consideration may be given before the Building Contractor commences the building works in accordance with the building Program in the areas concerned. The Contractor is required to mark out at the relevant locations of the Site the exact positions and sizes of all such works and to provide detailed information of such works to the Building Contractor to facilitate him to carry out the builder's work as the works proceed.

The Contractor is also required to set all sleeves in masonry and concrete works, of the correct size and at the correct location, before the works are carried.

All 'cutting-away' and 'making-good' shall be carried out by the Contractor or charged to the Contractor, if these works are not coordinated and done in time while the civil works are being executed.

All expenses properly incurred and losses suffered by the Company Representative as a result of the Contractor's failure to comply with the above requirements are recoverable by the Company Representative from the Contractor's bills.

6.3 Coordination of Contract Works

The Contractor shall coordinate the Works with those works of the Building Contractor and any other contractors and sub-contractors.

The Contractor shall note that the drawings supplied to him only indicate the approximate locations of the works. He shall make any modification reasonably required of his Program, work sequence and physical deployment of his works to suit the outcome of work coordination or as necessary and ensure that all cleaning, adjustment, test and control points are readily accessible.

The Contractor shall pay particular attention to the building works Program and shall plan, coordinate and Program his works to suit and adhere to the building works in accordance with the building Program.



SPECIFICATIONS

PROJECT NO : 1890
PROJECT TITLE : SSGCL HEAD OFFICE BUILDING, KARACHI
DATED : 20TH APRIL, 2026

Any significant problems encountered during the coordination work, which are beyond the Contractor's control, shall promptly be reported to the Engineer/ Company.

6.4 Cooperation with other Contractors

The Contractor shall cooperate at all times with the Building Contractor and all other contractors and sub-contractors in order to achieve efficient workflow on Site.

Any significant problems beyond the Contractor's control shall promptly be reported to the Engineer/ Company.

6.5 Site Supervision

The Contractor shall keep on the Site a Site Engineer along with a team of competent and technically qualified site supervisors to control, supervise and manage all the Works on Site. The Site Engineer shall be vested with suitable powers to receive instructions from the Engineer/ Company.

The team shall be of adequate strength and all personnel deployed on site by the Contractor shall be technically competent and have adequate site experience for the Works. The Contractor shall submit the CV of all such personnel and obtain approval from the Engineer/ Company prior to their deployment on site. The Contractor shall immediately replace any site supervisor whose experience, skill or competency is, in the opinion of the Engineer/ Company, found to be inadequate for the particular work.

All such approvals provided by the Engineer/ Company shall not relieve the Contractor from any and all obligations of the Contract. The Contractor shall also refer to the Conditions of Contract for other specific requirements, if any, on site supervision.

7. **Codes, Permits & Inspection:**

- a) All works shall meet or exceed the latest requirements of all authorities exercising jurisdiction over construction work at the project site.
- b) All required permits and inspection certificates shall be obtained, paid for, and made available at the time of completion of the Works.
- c) All work shall be carried out in accordance with the following codes:
 - i) HVAC Works:
 - Uniform Mechanical Code
 - KBCA Building Rules
 - ASHRAE Standard
 - SMACNA
 - NFPA
 - ii) Plumbing Works:
 - Uniform Plumbing Code
 - KBCA Building Rules
 - iii) Electrical Works:
 - IEE Wiring Regulation
 - Pakistan Electricity Rules
 - Electric Inspectors Regulation & Requirements



SPECIFICATIONS

PROJECT NO : 1890
PROJECT TITLE : SSGCL HEAD OFFICE BUILDING, KARACHI
DATED : 20TH APRIL, 2026

- NFPA Standards

8. Drawings by the Contractor:

8.1 Shop Drawings

- The Contract Drawings are schematic and are intended to enable the Contractor to prepare his estimate and submit a tender. The contract drawings are not intended to be used as shop drawings and will not be used for execution. Contractor shall prepare installation (Shop) drawings for execution of his works.
- If the Contractor requires any further instructions, details, contract drawings or information drawings to enable him to prepare his working drawing he will apply in writing to the Engineer/ Company for such information well in advance of application of such information.
- All shop drawings shall be prepared on computer using current version of AUTOCAD software.
- Prior to commencement of works on site and at least 3 weeks in advance of the drawings being required for actual execution, the Contractor shall submit hard-copies of shop drawings in triplicate plus soft-copy on AUTOCAD CD (both PDF & DWG format) for approval of the Engineer/ Company. The Engineer/ Company shall review the drawings & (i) approve the drawing or, (ii) disapprove the drawings with comments or, (iii) disapprove the drawings with comments for rectification/revision. In the event of (iii), the Contractor shall correct/revise the drawing & resubmit 3 hard-copies of the drawings plus soft-copy on AUTOCAD CD to the Engineer/ Company for Approval. On a drawing being approved, the Contractor shall submit 6 hard-copies plus soft-copy on AUTOCAD CD for formal approval and distribution to relevant offices.
- All drawings shall show plans and sections with sufficient details to clearly reflect the installation of the plant. All material specifications shall be provided on the drawings. All information required for preparing suitable foundation, for providing suitable access to the plant, for making openings in building structure, for coordination with electrical, plumbing, air-conditioning and other designs etc., shall be clearly provided.
- The Contractor shall submit to the Engineer/ Company, 3 sets of hard-copy drawings plus soft-copy on AUTOCAD CD showing all major holes, cavities, embedded frames and other parts of the plant to be embedded in the floor, ceiling and walls, channels in the floors, cable trenches, cement pipes or other major conduits, which are needed for the successful and timely completion of the works. The Engineer/ Company, after ascertaining the accuracy of these drawings, shall return 1 (one) set of the drawings to the Contractor, within 14 days of the receipt of these drawings.
- All shop drawings shall be fully dimensioned and suitably scaled showing construction, sizes, weights, arrangements, operating clearances and performance characteristics.
- Shop drawings shall only be of standard sizes of A0, A1 size as per ISO 5457:1999, as approved by the Engineer.
- Installation shall not be allowed to commence unless approved shop drawings are in possession of the Contractor, for which purpose shop drawings shall be submitted by the Contractor to the Engineer/ Company, sufficiently in advance of actual requirements to allow for ample time to the Engineer in checking and approval and no claim for extension of the Contract time will be considered by reason of the Contractor's failure to submit the drawings on time.

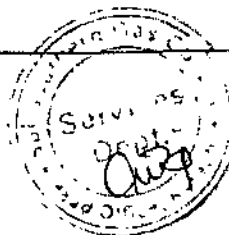

SPECIFICATIONS

PROJECT NO : 1890
PROJECT TITLE : SSGCL HEAD OFFICE BUILDING, KARACHI
DATED : 20TH APRIL, 2026

- j) Each shop drawing submitted by the Contractor shall include a certificate by the Contractor that all related conditions on site relevant to the particular installation have been checked and that no conflict exists.
- k) Any expenses resulting from an error mistake or omission in or delay in delivery of the drawings & information mentioned in sub-clause (b) of this clause shall be borne by the Contractor.
- l) Drawings approved shall not be departed from except on the instructions of the Engineer/ Company.
- m) The approval by the Engineer for any submitted data, working drawings, performance curves, test certificates for any items, arrangements and/or layout shall not relieve the Contractor for any responsibility regarding the performance of the Contract. Such approval shall also not relieve the Contractor from responsibility of any error in the submitted data & workings, brought to light at any time subsequent to any approvals.

8.2 Civil Work Drawings

The Contractor shall submit to the Engineer/ Company, in accordance with the approved "Submission Schedule", 6 copies of drawings showing details of all civil work to be done by this Contractor or other contractors as noted below:

- a) Equipment foundation drawings, duly coordinated with the equipment certified dimensions, and indicating the weight and the load on each support of equipment.
- b) Plant room drawings, clearly indicating the details and positions of all openings, trenches, ducts and cutting required and construction details needed to complete the Works.
- c) Elevations of all masonry and concrete and other walls, clearly indicating the dimensions and locations of all openings required and the type and design of the sleeves to be installed.

8.3 Manufacturer's Shop Drawings

The drawings shall show detailed construction, principal dimensions, weights and clearances for maintenance, etc. Immediately after placing of any order or at any event within 4 weeks unless otherwise approved in writing by the Engineer/ Company, the Contractor shall forward to the Engineer/ Company for comment, 4 copies of manufacturer's shop drawings indicating detailed construction, principal dimensions and weights, clearances for withdrawals and/ or cleaning, etc. No work shall proceed on or off Site unless drawings requiring approval are so approved in writing by the Engineer/ Company.

8.4 Record Drawings

The Contractor shall maintain an accurate record of changes as work progresses on a set of Record Drawings, which shall be maintained at Site, and the following procedure shall be adopted:

- a) Make records in a neat and legibly printed manner with a non-smudging medium.
- b) Identify each Record Drawing as the "Project Record Copy", maintain Drawings in good condition, do not use them for construction purposes, and make them readily available to the Engineer/ Company.
- c) Maintain project Record Drawings in a state current to the project. Failure to comply with this requirement may prejudice Progress Payments. The Engineer/ Company visual inspection shall constitute proof that Record Drawings are current.



SPECIFICATIONS

PROJECT NO : 1890
PROJECT TITLE : SSGCL HEAD OFFICE BUILDING, KARACHI
DATED : 20TH APRIL, 2026

- d) If the Contractor fails to produce either the marked-up drawings during the execution of the works or the record drawings, etc. for the Engineer/ Company Engineer approval, within one month after sectional or practical completion, the Engineer will have the right to have these drawings produced by others. The cost of obtaining the necessary information and preparing such drawings etc. will be deducted from the outstanding payments owing to the Contractor.

8.5 As-Built Drawings

- a) The Contractor shall submit 3 sets of the first draft prints of As-Built drawings within 28 days of the issuance of the Certification of Completion to the Engineer/ Company for checking. The Engineer/ Company after checking the above draft prints shall return one set of the marked up copies of these As-Built drawings to the Contractor within 42 days from the date of submission of the Contractor's draft prints with comments. The Contractor shall within a further 28 days from the date of receiving the Engineer/ Company comments on the draft As-Built drawings re-submit to the Engineer/ Company for his approval another 3 sets of the second draft prints of As-Built drawings with the Engineer/ Company comments incorporated. This process of submission and approval shall continue until the final approval of the Engineer/ Company on these As-Built drawing is obtained.
- b) The Contractor shall ensure all As-Built drawings are accurate representation of the complete Works, before submitting them to the Engineer/ Company.
- c) As-built drawings shall only be of standard sizes of A0, A1 size as stipulated in ISO 5457:1999, as approved by the Engineer.
- d) The final approved As-Built drawings shall be in 6 sets of hard copy and 3 sets of electronic copies. These shall be submitted within 21 days from the date of final approval. Each electronic copy shall be in the form of CD-ROM (both in PDF & DWG formats), labeled, with cross reference to a printed list of files explaining the contents and purpose of each file and supplied in sturdy plastic containers.

9. Verification of Actual Dimensions on Site:

- a) The Contractor shall be solely responsible for verification of actual site dimensions and building layout. Building layouts shown on Engineer's drawings shall not be considered to be final with regard to dimensions and layout but shall be subject to actual verification by the Contractor. All working drawings prepared by the Contractor shall incorporate actual measurements taken on site. The Contractor shall ensure that all equipment can be conveniently fitted into the space allocated for this purpose.
- b) If any space allocated for certain equipment or combination of equipments is insufficient or deficient in terms of clearances required for maintenance etc., the Contractor shall forthwith inform the Engineer/ Company of the discrepancy. He shall provide all reasonable assistance to the Engineer/ Company for verification of the same and for taking remedial measures. It is understood that all tenderers during tendering shall have checked that the equipment proposed to be supplied by them fits conveniently into the space allocated for this purpose. In case any such space is insufficient, the tenderer shall so indicate the deficiency in his tender documents and specify the space requirements. Failure on the part of the tenderer to point out any discrepancies existing in this regard shall make him liable, if his tender has been accepted, to bear the full consequences developing out of any equipment not fitting into the space allocated for the purpose.
- c) If any time during the progress of the Works any error shall appear or arise in the position, levels, dimensions or alignment of any part of the works, the Contractor on being required to do so by the Engineer/ Company shall at his own expense rectify such error to the satisfaction of the Engineer/ Company unless such error is based on incorrect data supplied in writing by the Engineer/ Company, in which case the expense of rectifying the same shall be borne by the Company Representative. The



Fahim, Nanji & deSouza (Pvt.) Ltd.
Consulting Engineers

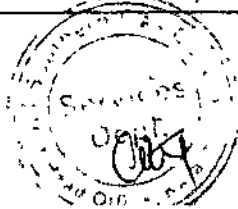

Basic Mechanical Requirements
Section 23 05 01 - 7



SPECIFICATIONS

PROJECT NO : 1890
PROJECT TITLE : SSGCL HEAD OFFICE BUILDING, KARACHI
DATED : 20TH APRIL, 2026

checking of any setting out or of any line or level by the Engineer/ Company shall not in any way relieve the Contractor of his responsibility for correctness thereof and the Contractor shall carefully protect and preserve all bench marks, site rails, pegs and other things used in setting out the Works.

10. Responsibility for Accuracy of Information:

- a) The Contractor shall be fully responsible for accuracy of all information necessary for successful and timely completion of the works.
- b) The Contractor shall be responsible to make all measurements and set out all the necessary dimensions for their correctness.
- c) The Contractor shall be fully responsible for ascertaining the accuracy of the dimensions and other information given in the tender documents before carrying out the work. The Contractor shall provide the complementary dimensions and communicate the same to the Engineer/ Company.
- d) The Contractor shall consult the drawings and documents which have been prepared for the Civil and other contracts by other Engineer/ Company, which can effect his work and which are either kept on site or are available with the other Engineer/ Company.
- e) It shall be the responsibility of the Contractor to acquire all necessary information and ascertain its accuracy for co-ordination of the works with the works of other Contractors.

11. Approval for Material & Equipment:

- a) General: All equipment and material to be used in the Works shall be subject to approval obtained prior to delivery of the same on site. It is to be specifically noted that any approval given by the Engineer/ Company shall not relieve this Contractor of his obligations under this Contract.
- b) Approval of Imported Equipment: For approval of all equipment, the Contractor shall be required to submit, within two weeks of the signing of the Contract, detailed submittals stating the equipment proposed to be supplied and providing supporting literature/ brochures etc., to enable the "ENGINEER" to check conformance to the specifications. Performance curves and charts shall be submitted with the operating points clearly marked. The selection procedure for Chillers, AHU's FCU's, etc., shall be submitted in detail on type-written sheets. All equipment submittals shall be accompanied with a certificate stating that the equipment proposed to be supplied fits into the space allocated for it with sufficient clearance around it to allow for installation of related ducting, piping, etc., and provides for maintenance clearances as required by the manufacturer of the equipment, and that all special requirements of the equipment have been accounted for. Any additional information, test reports etc., required by the "Engineer" shall be furnished by the Contractor. All work related to the equipment shall only be commenced after receipt of written approval from the "Engineer".
- c) Approval of Locally Manufactured Equipment: The procedure of approval of locally manufactured equipment shall be the same as stipulated above for imported equipment. Additionally all locally manufactured equipment shall be inspected at the manufacturer's premises by the Engineer/ Company, and approval given prior to delivery on site.
- d) Approval of Imported Material: All imported material to be used in the works shall be submitted to the Engineer/ Company and approval obtained. Manufacturer's literature/brochure etc. that provide complete information on the material specifications, to enable the Engineer/ Company to check conformance to specification, shall be submitted. Any additional information, test reports etc., required by the Engineer/ Company shall be supplied by the Contractor.
- e) Approval of Locally Procured Material: All locally procured material shall be submitted to the Engineer/ Company for approval, and approval obtained prior to delivery of the



SPECIFICATIONS

PROJECT NO : 1890
PROJECT TITLE : SSGCL HEAD OFFICE BUILDING, KARACHI
DATED : 20TH APRIL, 2026

same on site. The procedure for obtaining approval shall generally be the same as given above for imported material, except that where manufacturer's literature is not available, a sample of the material shall be submitted along with type written notes indicating relevant source data and specs on the material. Any other samples, information, test reports etc., required by the Engineer/ Company shall be submitted.

12. Storage Arrangements:

- a) The Contractor shall make adequate arrangements for the storage of the materials arranged by him or supplied by the Company Representative. No payment shall be made to the Contractor for storage arrangements whatsoever. However adequate space for stores shall be provided on site to the Contractor.
- b) The location of the store area shall be within the Site premises and/or selected with the consultation and approval of the Engineer/ Company.

13. Cutting & Patching:

- a) Cutting will be done under Specifications of other trades. Perform cutting, fitting and patching of mechanical equipment and materials required to:
 - i) Set openings and sleeves for ducts & pipes accurately before the structural concrete are poured or set boxes on the forms so as to leave openings in the structure in which the required sleeves can be subsequently located in which case Contractor shall fill in the concrete voids around the sleeves.
 - ii) Uncover work to provide for installation of ill-timed work.
 - iii) Remove and replace defective work.
 - iv) Remove and replace work not conforming to requirements of the Contract Documents.
 - v) Remove samples of installed work as specified for testing.
 - vi) Install equipment and materials in existing structures.
 - vii) Upon written instructions from the Engineer uncover and restore work to provide for observation of concealed work.
- b) All patching will be done under Specifications of other trades. Should the Contractor neglect to perform his preliminary work and should cuttings be required in order to install the piping or equipment, then the expense of the cutting and restoring of surface to their original condition shall be borne by the Contractor.
- c) Cut, remove and legally dispose of selected mechanical equipment, components and materials as directed by the Engineer, including but not limited to removal of mechanical piping, heating units and trim and other mechanical items made obsolete by new work.
- d) Protect structure, furnishings, finishes and adjacent materials not indicated or scheduled to be removed.
- e) Provide and maintain temporary partitions or dust barriers adequate to prevent the spread of dust and dirt to adjacent areas.
- f) Patch and refinished existing finished surfaces and building components using new materials matching existing materials and experienced installers.

14. Measuring Instruments:

The Contractor shall acquire and maintain on site various required measuring instruments in perfect working condition to enable the representative of the Company/Engineer/ to check the quality and standard of all material and performance of equipments.

SPECIFICATIONS

PROJECT NO : 1890
PROJECT TITLE : SSGCL HEAD OFFICE BUILDING, KARACHI
DATED : 20TH APRIL, 2026

15. Standards & Typical Design:

The specification either cites or implies IEEE, IEC, ASME, ASHRAE, or BS Standards where the context so refers. Other comparable United States, European or Japanese standards and typical designs are equally acceptable providing that they in no way detract from the quality, safety, operability or durability of the equipment and material furnished. However, when other standards or typical designs than those cited or implied are offered by a tenderer, he shall set forth in his proposal the alternate standards and/or designs he proposes so that a direct comparison can be made by the Engineer/ Company before the issue of a Letter of Award. Each specific difference from the specifications shall be clearly spelled out by the tenderer. If no alternates are set forth by the Tenderer in his proposal, it will be assumed that the equipment and material will be in accordance with the standards and typical designs as cited or implied in the Specifications.

16. Abbreviations for Standards:

The standards, codes of practice and recommendations of the following societies or institutions have either been used in the specifications and are cited here as a general level of quality for the equipment, materials and workmanship.

a) Abbreviations for International institutions are given below:

- International Electro technical Commission ... IEC

b) Abbreviations for some European societies and standards institutions are as follows:

- Association Francaise de Normalisation ... AFN
- American Society of Heating Refrigeration
Air-conditioning Engineer/Engineers Inc. ... ASHRAE
- British Standard Institution ... BSI
- Chartered Institution of Building Services ... CIBS
- Dentsches Institute fur Normung ... DIN
- Institution of Electrical Engineer/Engineers, London ... IEE

c) Abbreviations for Pakistani Societies and Standard Institutions:

- Pakistan Standards Institution ... PSI
- Water and Power Development Authority ... WAPDA

d) Abbreviations for various United States Societies and Standard Institutions:

- American Standards Association ... ASA
- American Society of Heating, Refrigerating and
Air-conditioning Engineer/Engineers ... ASHRAE
- American Society of Mechanical Engineer/Engineers ... ASME
- National Electrical Manufacturers Association ... NEMA
- American Society for Testing and Material ... ASTM
- American Refrigeration Institute ... ARI
- Sheet Metal and Air-conditioning
Contractors National Association ... SMACNA
- Instrument Society of America ... ISA
- National Bureau of Standards ... NBS
- National Fire Protection Association ... NFPA



SPECIFICATIONS

PROJECT NO : 1890
PROJECT TITLE : SSGCL HEAD OFFICE BUILDING, KARACHI
DATED : 20TH APRIL, 2026

- Thermal Insulation Manufacturer's Association ... TIMA

- e) Where differences or contradictions appear between any of the laws, standards, codes, specified herein, the decision of the Engineer shall be final and binding on the Contractor and the Contractor shall not claim any additional charges for carrying out the same.

17. Operating & Maintenance Instructions:

- a) Framed Instructions: Approved piping, wiring and control diagrams showing the complete layout of the entire system, including equipment, piping, valves and control sequence, framed under glass or in approved laminated plastic, shall be posted; where directed. In addition, condensed operating instructions, explaining preventive maintenance procedures, methods of checking the system for normal safe operation, and procedures of safely starting and stopping the system shall be prepared in typed form, framed as specified above and posted beside the diagrams. Proposed diagrams, instructions and other sheets shall be submitted for approval prior to the posting. The framed instructions shall be posted before acceptance testing of the system.
- b) Field Instructions: During the two months of the operation and maintenance period upon completion of the work the services of one or more project engineers shall be provided by the Contractor to instruct the representative of the Company Representative in the operation and maintenance of the Works. The field instructions shall cover all the items contained in the bound instructions.

18. Operation & Maintenance (O&M) Manual & User Manual:

18.1 General

The Contractor shall provide two types of manuals to the Engineer/ Company with all changes made to the installation during the course of the Contract suitably incorporated.

The "O&M Manual" is for use by the maintenance contractor of the completed installation. It shall contain detailed technical information covering both operation and maintenance aspects of the installation.

The "User Manual" seeks to give users of the completed installation an overview of the essential information of the installation. The contents of the manual should be concise and succinct for ease of comprehension by people with a non-technical background.

18.2 Presentation

All manuals shall be written in English, unless otherwise specified. The text of descriptive parts shall be kept concise while at the same time ensure completeness. Diagrammatic materials shall also be supported by comprehensive descriptions.

The manuals shall comprise A4 size loose-leaf, where necessary, A3 size folded loose-leaf. The loose-leaves shall be of good quality paper that is sufficiently opaque to avoid "show-through". Unless otherwise specified in the Contract, the manuals shall be bound in durable loose-leaf four ring binders with hard covers.

The manuals shall have labels or lettering on the front cover and spine. The Engineer/ Company approval shall be obtained on this at the draft manual stage. The electronic copy of manuals including the technical literatures shall be in PDF format.

18.3 Checking and Approval

The Contractor shall submit 3 sets of the first draft of O&M Manuals together with a list of recommended spare parts for one year's operation and a list of special tools both complete with prices to the Engineer/ Company for comment within



SPECIFICATIONS

PROJECT NO : 1890
PROJECT TITLE : SSGCL HEAD OFFICE BUILDING, KARACHI
DATED : 20TH APRIL, 2026

28 days of the issuance of the Completion Certificate.

The Contractor shall submit 2 sets of the first draft of the User Manual to the Engineer/ Company for comment at least 56 calendar days before the date of completion. The Engineer/ Company will check the drafts and return them to the Contractor within 42 days from the date of submission with comments necessary for a final and approved set of document. The Contractor shall then make all necessary amendments to the documents and resubmit them to the Engineer/ Company within 21 days from the date of receipt of comments.

The Contractor shall submit 3 sets of hard copies (one of which shall be the original) and one set of electronic copy of the final approved O&M Manuals in CD-ROM within 21 days from the date of approval by the Engineer/ Company. The Contractor shall submit 6 sets of hard copies and 3 electronic copy of the final approved User Manuals in CD-ROM within 21 days from the date of approval by the Engineer/ Company.

18.4 Structure and Content of O&M Manual

The detailed requirements, structure and contents of the O&M Manual shall include the following information under separate sections where appropriate:

(a) Project Information

This shall include: Project title, site address, contract no., contract title, contractor/sub-contractor name, address, contact persons and their telephone/fax nos., contract commencement date, substantial completion date and end date of operation & maintenance period.

(b) System Description

- (i) Type(s) of system(s) and equipment installed;
- (ii) Design criteria, design data and parameters;
- (iii) Locations of the system and major equipment, and what they serve;
- (iv) Description of operation and functions of the system and equipment;
- (v) General operating conditions, expected performance and energy and resources consumption where applicable.

(c) List of Installed Equipment

Schedule of all items of equipment and plant stating the location, name, model no., manufacturer's serial or reference no., manufacturer's design duties and data.

(d) Spare Parts and Special Tools Lists

- (i) List of Spare Parts supplied by the Contractors: Item descriptions, supplied quantities, model nos. manufacturer's serial or reference nos. and storage locations.
- (ii) Recommended Spare Parts List and Special Tools List: Manufacturers'/ suppliers' recommendations for spare parts and special tools with item description, unit rate, recommended stock quantities as well as the agents for the spare parts and special tools.

(e) Manufacturers' Certificates/Guarantees

- (i) Manufacturers' certificates such as factory test certificates, laboratory test reports and guarantees and any others where required for the equipment and plants, etc.
- (ii) Originals of Statutory Inspection Certificate for various installations.



SPECIFICATIONS

PROJECT NO : 1890
PROJECT TITLE : SSGCL HEAD OFFICE BUILDING, KARACHI
DATED : 20TH APRIL, 2026

including:

[Note: Testing records & commissioning data (other than the types prescribed above), which are required under the Contract are checked and endorsed separately by the Engineer/ Company and do not form part of the O&M manuals.

(f) Safety Precautions for Operation and Maintenance

State, where applicable, hazard warnings and safety precautions of which the operation and maintenance staff need to be aware:

- (i) mandatory requirements relating to safety;
- (ii) known hazards against which protection measures shall be taken; and
- (iii) known features or operational characteristics of the installed equipment or systems which may cause hazard and the related safety precautions.

(g) Operation Instructions

Instructions for the safe and efficient operation, under both normal and emergency conditions, of the installed system which shall comprise:

- (i) an outline of the operating mode;
- (ii) control logic and data (sequence, effect, limits of capability, modes and set points);
- (iii) procedures and sequences for start-up and shut-down;
- (iv) interlocks between equipment/system;
- (v) calling on of stand-by equipment;
- (vi) precautions necessary to overcome known hazards;
- (vii) means by which any potentially hazardous equipment can be made safe;
- (viii) estimation of energy consumption and energy costs;
- (ix) forms for recording plant running hours, energy consumption and energy costs; and
- (x) operating data such as running current, operating pressure, operating flow rates, etc.

(h) Maintenance

(i) Maintenance instructions

Manufacturers' and the Contractor's recommendations and instructions for the maintenance of the installed equipment. Clear distinction should be made between planned tasks (preventive maintenance) and fault-repair tasks (corrective maintenance). Instructions shall be given on each of the following, as appropriate:

- (a) nature of deterioration, and the defects to be looked for;
- (b) isolation and return to service of plant and equipment;
- (c) dismantling and reassembly;
- (d) replacement of components and assemblies;
- (e) dealing with hazards which may arise during maintenance;
- (f) adjustments, calibration and testing; and
- (g) special tools, test equipment and ancillary services.



SPECIFICATIONS

PROJECT NO : 1890
PROJECT TITLE : SSGCL HEAD OFFICE BUILDING, KARACHI
DATED : 20TH APRIL, 2026

(ii) Maintenance schedules

Proposed maintenance schedules for all the preventive maintenance tasks identified above. The schedules shall be based on both manufacturers' recommendations and other authoritative sources (e.g. statutory or mandatory requirements) and should include:

- (a) routine servicing;
- (b) inspections;
- (c) tests and examinations;
- (d) adjustments;
- (e) calibration; and
- (f) overhaul

The frequency of each task may be expressed as specific time intervals, running hours or number of completed operations as appropriate. Collectively, the schedules will form a complete maintenance cycle, repeated throughout the whole working life of the installation.

- (a) Drawing Lists
- (b) A complete list of as-built drawings identified with drawing number/reference;
- (c) A complete list of manufacturers' shop drawings with drawing number/reference, where applicable; and
- (d) A brief description of CD-ROM for these drawings.
- (e) Technical Literatures

A complete set of manufacturers' literatures for all the plant and equipment installed in the system. The contents of these literatures shall cover the following areas where applicable:

- (a) description of equipment with model numbers highlighted;
- (b) performance –behavioral characteristics of the equipment;
- (c) applications –suitability for use;
- (d) factory/laboratory test reports, detailed drawings, circuit diagrams;
- (e) methods of operation and control;
- (f) operation instructions;
- (g) cleaning and maintenance requirements;
- (h) plants, materials and space required for maintenance;
- (i) protective measures and safety precautions for operation and maintenance; and part lists
- (j) Contact addresses and telephone numbers of suppliers of major equipment

18.5 Structure and Content of User Manual

The detailed requirements, structure and contents of the User Manual shall include, where applicable, the following information:

(a) Project Information

This shall include: Project title, site address, contract no., contract title, contract commencement date, substantial completion date and end date of



SPECIFICATIONS

PROJECT NO : 1890
PROJECT TITLE : SSGCL HEAD OFFICE BUILDING, KARACHI
DATED : 20TH APRIL, 2026

Maintenance Period.

(b) System Description

- (i) Type(s) of system(s) and equipment installed, and their purposes;
- (ii) Locations of major plant spaces and riser ducts;
- (iii) Brief description of the operation and functions of the systems and equipment; and
- (iv) Listing of set points which can be adjusted by the user to suit their operation needs. -

(c) Schedule of Major Plant Spaces and Installed Equipment

- (i) Schedule of major plant spaces and riser ducts including their locations; and
- (ii) Schedule of major equipment and plants including their locations and serving areas.

(d) Safety Precautions for Operation

Any safety precautions and warnings signals that the users shall be aware of in the daily operation of the various systems and equipment in the installation including:

- (i) mandatory requirements relating to safety;
- (ii) features or operational characteristics of the installed systems or equipment which may cause hazard and the related safety precautions;
- (iii) protective measures and safety precautions for operation; and
- (iv) list of warning signals and the related meanings that the user shall be aware of and the actions to be taken

(e) Operation Instructions

Instructions for the safe and efficient operation, under both normal and emergency conditions, of the installed system which shall comprise:

- (i) an outline of the operating mode;
- (ii) step by step operation instructions for systems and equipment that are to be operated by the user, including at least procedures for start-up and shut-down;
- (iii) means by which any potentially hazardous situation can be made safe;
- (iv) cleaning and basic maintenance procedures.

(f) List of Statutory Periodic Inspections and Tests

A schedule of periodic inspections and tests that Company Representative and/or user of the installation have to arrange to achieve compliance with the requirements stipulated in the relevant Laws (if any). The frequency of such inspections and tests shall be expressed in specific time intervals.

(g) Drawings

A set of selected as-built drawings which shall be able to illustrate to the user the general layout of the completed installation.

(h) Photographs

A set of photographs with suitable captions to illustrate to the user the appearance and locations of devices which require their setting and operation.



SPECIFICATIONS

PROJECT NO : 1890
PROJECT TITLE : SSGCL HEAD OFFICE BUILDING, KARACHI
DATED : 20TH APRIL, 2026

19. Mechanical Installations:

Sequence, coordinate, and integrate the various elements of mechanical systems, materials and equipment. Comply with the following requirements:

- a) Coordinate mechanical systems, equipment and materials installation with other building components
- b) Verify all dimensions by field measurements.
- c) Arrange for chases, slots and openings in other building components during progress of construction, to allow for mechanical installations.
- d) Coordinate the installation of required supporting devices and sleeves to be set in poured-in-place concrete and other structural components, as they are constructed.
- e) Sequence, coordinate and integrate installations of mechanical, materials and equipment for efficient flow of the Work. Give particular attention to large equipment requiring positioning prior to closing the building.
- f) Install systems, materials and equipment to conform with approved submittal data, including coordination drawings, to greatest extent possible. Conform to arrangements indicated by the Contract Documents, recognizing that portions of the work are shown only in diagrammatic form. Where coordination requirements conflict with individual system requirements, refer conflict to the Engineer/ Company.
- g) Install systems, materials and equipment level and plumb, parallel and perpendicular to other building systems and components, where installed exposed in finished spaces.
- h) Install mechanical equipment to facilitate servicing, maintenance, and repair or replacement of equipment components. As much as practical, connect equipment for ease of disconnecting, with minimum of interference with other installations. Extend grease fittings to an accessible location.
- i) Install access panel or doors where units are concealed behind finished surfaces.
- j) Install systems, materials and equipment giving right of-way priority to systems required to be installed at a specified slope.
- k) Provide fire stopping materials in all annular spaces surrounding piping, conduits, ducts, etc. that penetrate fire-resistive construction.

20. Delivery of Equipment / Material on Site:

No plant or Contractor's Equipment shall be shipped or delivered to the Site until intimation in writing has been applied for and obtained by the Contractor from the Engineer/ Company that the plant may be delivered. The Contractor shall be responsible for the reception on Site of all plant and Contractor's Equipment delivered for the purpose of the Contract.

All materials delivered to Site shall be accurately listed and recorded in the site record books maintained on site by the Contractor and shared with Company Representative's Project Manager.

Materials and equipment delivered to Site and paid for in interim payment shall be the Company Representative's property. Such materials and equipment shall not be removed from Site without the approval of the Engineer/ Company in writing and appropriate deduction shall be made in the next interim payment in accordance with the Contract.

21. Unloading & Storage at Site:

- a) The Contractor shall unload all owner supplied or otherwise equipment & material at the site from delivery vehicles as the case may be. Items for permanent installation shall be properly stored in areas designated by the Engineer/ Company and shall be protected as required to prevent damage or deterioration of any type. Storage methods

SPECIFICATIONS

PROJECT NO : 1890
PROJECT TITLE : SSGCL HEAD OFFICE BUILDING, KARACHI
DATED : 20TH APRIL, 2026

shall be such as to cause minimum inconvenience to others and shall be arranged to facilitate inspection.

- b) All equipment and material storage shall be subject to the approval of the Engineer/ Company.
 - i) Items stored shall be blocked up at least six (6) inches off the ground.
 - ii) The ends of all nozzles, pipes, tubes and conduits while in storage at the site shall be covered with a tube cap to save against entrance of rain water, blowing dirt, and other foreign matter. Tubing shall be shipped and stored in neat bundles.
 - iii) Miscellaneous steel, plate work, pipes, etc. shall be protected by a prime coat of paint and kept painted throughout the storage and erection period to inhibit rusting unless such items are galvanised or have other corrosion proof finish.
- c) All packing boxes, shipping containers, planking, covering, etc., shall become the property of the Company Representative as soon as the equipment and material which is contained therein arrives at the site. The Company Representative, on application from the Contractor, may permit the Contractor to use some of the boxes, containers, etc., without charge for equipment and material storage purposes.

22. Equipment Lifting:

- a) The contractor shall be solely responsible for safe lifting of the equipments from place of storage to location of final installation and finally on the foundations.
- b) Prior to lifting the equipments the following procedure shall be adopted:
 - i) Submit comprehensive insurance policy for the full value of the equipment to the Engineer/Company Representative from approved insurance company.
 - ii) Submit complete information of specialist firm of lifters/riggers to the Engineer/ Company & obtain approval.
 - iii) Submit complete procedure & equipment to be used for lifting the equipment in place. Identify on plans location of tripods, hoist, etc. that will transfer weight to the equipment, to the structure & obtain approval.
 - iv) All the above to be completed with one month before the date of lifting of equipment.

23. Qualification of Equipment & Material Manufacturer:

- a) All minor equipment and all materials shall be manufactured by companies which have had at least five years previous experience in the design and manufacture of equipment and or material of comparable type, capacity and operating conditions.
- b) Where the requirements of this clause make any material non-obtainable the Company Representative and/or Engineer/Company reserves the right to waive any portion or portions of it as required to obtain the intent of the Specifications.
- c) When manufacturer's product is specified by name or equivalent, it shall be the sole judgement of the Engineer/Company to determine the acceptability of any product which is offered as an equal to that specified.
- d) Proposals shall be based on the equipment and materials specified, and any request to substitute any time shall be so mentioned in the proposal and the amount to be added or deducted shall be given. Any request for substitution after the date of Letter of award shall likewise be accompanied with the difference in price.
- e) If the Contractor in his tender proposal has offered more than one source of equipment or material the selection of the source shall be at the judgement of the Engineer/ Company.

SPECIFICATIONS

PROJECT NO : 1890
PROJECT TITLE : SSGCL HEAD OFFICE BUILDING, KARACHI
DATED : 20TH APRIL, 2026

24. Safety Program:

- a) The Contractor shall strictly follow at his own cost the Safety Program outlined below and such additional measures as the Engineer or Engineer/ Company Representative may determine to be reasonably necessary.
 - i) Prior to commencement of work the successful Contractor shall submit safety Program for discussion with the Company Representative and the Engineer/ Company.
 - ii) The Contractor shall prepare a plan of the Works' Site to assure that storage areas for materials and equipment are located on the project/work site for maximum efficiency. This plan will be subject to the approval of the Engineer/ Company.
 - iii) Activities between different operations and different crafts will be co-ordinated.
 - iv) The Contractor shall layout and provides an efficient access system with information and directional signs posted as necessary.
 - v) All employees will be instructed on safe work method.
 - vi) The Contractor shall advise all his supervisory staff of their responsibility for the prevention of injury to persons or damage to property or equipment in their respective areas of supervision.
 - vii) Safety will be included in all job planning. This will include providing safe construction equipment and vehicles, protective equipment necessary for protection of workmen, and establishing methods for safe operation.
 - viii) Good housekeeping will be maintained at all times.
 - ix) Scaffolds, ladders, ramp", runways etc. will be constructed properly and maintained in safe conditions.
 - x) Ample fire protection will be provided and fire hazards guarded, by the Contractor.
 - xi) Adequate lighting, ventilation etc. will be provided as necessary, by the Contractor.
 - xii) Equipment will be properly and regularly inspected and maintained by the Contractor to the satisfaction of the Engineer/ Company.
 - xiii) The Contractor will assign to his employees only such duties as are within their physical and mental capabilities.
 - xiv) The Contractor will hold monthly meetings with his supervisory staff and the man incharge at the lower level will hold safety meetings of 10 to 15 minutes with his crew each week.
 - xv) First Aid facilities will be provided at job sites, the services of doctors and hospitals made available, and all supervisors instructed in handling of injured employees.
 - xvi) Adequate toilet facilities will be provided, maintained in a hygienic condition and their use enforced by the Contractor.
- b) Accident reports will be furnished to the Engineer/ Company for onward transmission to the Company Representative within 2 days of the reported accident.
- c) Copies of the safety Program will be supplied by the Contractor to the Engineer/ Company and will be promptly posted in all offices in use of projects/works under this Contract.
- d) At all construction sites the following instructions shall be followed:
 - i) availability of safety (hard) hats, which should be worn by anyone visiting or working within the designated work area
 - ii) controlled entry to the designated work area



SPECIFICATIONS

PROJECT NO : 1890
PROJECT TITLE : SSGCL HEAD OFFICE BUILDING, KARACHI
DATED : 20TH APRIL, 2026

- iii) proper distribution of temporary electric power (use of RCDs/ELCBs, switch gear, cabling, socket outlets)
 - iv) proper guarding of shafts, stairs and floor edges up, to a height of 42".
 - v) proper access stairs and ladders with handrails
 - vi) properly demarcated passageways, which are kept clear of materials, equipment, and rubbish
 - vii) daily cleaning of debris and rubbish from the site
 - viii) adequate temporary lighting
 - ix) proper housekeeping to reduce slipping and tripping hazards.
 - x) proper protection to pedestrians and adjoining buildings
 - xi) contractor's all-risk Insurance policy to be in place.
- e) To ensure safety of all people on the Site during the construction process, including Contractors' personnel and Company Representative's representatives, the following procedures shall be adopted by all Contractors for the use of temporary electricity supply.
- i) Work shall generally be carried out in accordance with 16th Edition of UK IEE Wiring Regulations, BS CP 1017 "Distribution of Electricity on Building Sites", and the Pakistan "Electricity Rules, 1937" all legal formalities of the Electric Inspector's office shall be complied with.
 - ii) Construction of cables used shall be as follows:
 - a) to fixed distribution boards and fixed equipment, PVC/PVC/SWA/PVC, to BS 6346.
 - b) to moveable plant, flexible armoured cables, to BS 6116.
 - c) to welding electrode-holders, flexible cables to BS 638.
 - d) to portable tools and hand-lamps, flexible cords to BS 6500
 - iii) Installation of cables shall be as follows:
 - a) outdoors, directly buried at least 500mm below grade, with tile covers and cable markers (at minimum 10 meter intervals and at bends), and in RCC pipe at road/traffic crossings.
 - b) indoors, clipped to the surface at least 3000mm above floor/ground level.
 - c) strain relief shall be provided at termination of all cables at equipment, plugs, etc.
 - iv) Double earthing, with stranded copper conductors, shall be used to establish a TNS system. No separate earthing electrodes are required at each location.
 - v) A main distribution board, to BS 4363, of totally enclosed sheet-steel construction (IP 54) shall be provided, with 30mA trip residual current device(s) for the earth-leakage protection of circuits. Short-circuit and overload protection shall be provided by circuit-breakers of the appropriate rupturing capacity.
 - vi) Plugs, sockets, and accessories of a robust, unbreakable construction, to BS 4343, shall be used for all equipment. Portable tools, to BS 2769, shall preferably be of double-insulated construction and be operated at 110V.
 - vii) A layout drawing of the proposed temporary installation with schematics, cable sizes and routes, earth conductors, and protection details shall be had approved from the Company Representative. After installation, test results (insulation resistance, earth-loop impedance, etc.) shall be submitted; re-testing shall be done every three months.

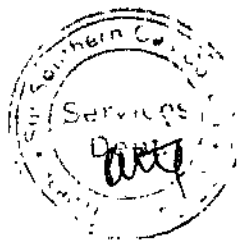

SPECIFICATIONS

PROJECT NO : 1890
PROJECT TITLE : SSGCL HEAD OFFICE BUILDING, KARACHI
DATED : 20TH APRIL, 2026

25. Guarantees / Warrantees for Equipment / Plant:

- a) The period of guarantee/warranty on the equipment/plant shall be the period stated in Conditions of Contract.
- b) The Contractor's guarantee does not cover the normal wear & tear.
- c) Manufacturer's equipment warranties if they exceed the Maintenance Period as defined in these Documents shall be transferred to the Company Representative at the end of the Maintenance Period.
- d) The Contractor shall guarantee that the material & workmanship incorporated into the plant/equipment are new and the best of their respective kinds for the service intended and that all items will be free from inherent defect in design, workmanship & materials, and that all equipment in its several parts will operate successfully at all capacities up to and including the maximum specified load without undue noise, heating, straining of parts, wear and vibration and that an ample factor of safety is included in every design.
- e) Guarantee/Warranty, shall be furnished by the Contractor upon forms approved by the Engineer/ Company and shall be signed by both the Contractor and the Sub-Contractors whose work is involved.
- f) If the equipment/plant manufacturer's standard guarantee/warranty is applicable, the guarantee/warranty form and conditions must be submitted along with the equipment/plant 'technical submittals'.
- g) The Contractor's liability shall be limited to the replacement of defective parts that may develop in the equipment or material of his own work or manufacture or his Sub-Contractors under proper use and arising solely from faulty design, material, or workmanship provided always that such defective parts are not repairable at the Site, and are not essential in the meantime for commercial use of the equipment, are promptly returned to the Contractor's or Sub-Contractor's factory unless otherwise arranged. The equipment so replaced or repaired shall be in conformity with the specifications.
- h) For indigenous equipment, all replacements shall be made free of cost at the Site by the Contractor.
- i) For imported equipment, all replacement shall be made free of cost ex-Karachi port, and the Company Representative shall arrange to have then cleared, pay all duties and hand-over the replaced parts to the Contractor.
- j) The return of defective parts to the Contractor's or Sub-Contractor's factory shall be the Contractor's responsibility and shall be made at his expense. The Company Representative will, however, render such assistance as necessary to expedite the same. In the case of defective parts not repairable at the site but essential in the meantime for the commercial use of the equipment, the Contractor shall, whenever possible, replace free of cost at the site the said defective parts before the defective parts are removed from the site.
- k) If it becomes necessary for the Contractor to replace or renew any defective portions of the Plant under this clause, the provisions of this clause will apply to the portions of the plant so replaced or renewed until the expiration of six months from the date of such replacement or until the end of the guarantee period, whichever shall be later. If any defects are not remedied within a reasonable time, the Company Representative, after due notice to the Contractor, may proceed with the work at the Contractor's risk and expense without prejudice to any other rights which the Company Representative may have against the Contractor in respect to such defects.
- l) If the replacements or renewals are of such a character as may effect the efficiency of the plant, the Engineer/ Company shall have the right to give to the Contractor within one month of such replacement or renewal, notice in writing that performance tests be made, in which case tests shall be carried out as provided in these Documents. Should



SPECIFICATIONS

PROJECT NO : 1890
PROJECT TITLE : SSGCL HEAD OFFICE BUILDING, KARACHI
DATED : 20TH APRIL, 2026

such tests show that the guarantees of the Contract are sustained; the cost of the tests shall be borne by the Company Representative. Should the guarantees not be sustained, the cost of the test shall be borne by the Contractor.

- m) If during the guarantee period the services of the Contractor's personnel are required for the rectification or replacement of any defective part or work due to defective material, design or workmanship, such services shall be made by the Contractor without charge to the Company Representative.

26. Tests on Completion:

- a) The Contractor shall give to the Engineer/ Company in writing 15 days notice of the date after which he will be ready to make the "Tests on Completion". Unless otherwise agreed the tests shall take place within 10 days after the said date on such day or days as the Engineer/ Company shall in writing notify the Contractor.
- b) If the Engineer/ Company fails to appoint a time after having been asked to do or to attend at any time or place duly appointed for making the said tests, the Contractor shall be entitled to proceed in his absence and the said tests shall be deemed to have been made in the presence of the Engineer/ Company.
- c) If in the opinion of the Engineer/ Company the tests are being unduly delayed he may, by notice in writing, call upon the Contractor to make such tests within 10 days from the receipt of the said notice, and the Contractor shall make the said tests on such day within the said 10 days as the Contractor may fix and of which he shall give notice to the Engineer/ Company. If the Contractor fails to make such tests within the time aforesaid, the Engineer/ Company may himself proceed to make the tests. All tests so made by the Engineer/ Company shall be at the risk and expense of the Contractor.
- d) The Company Representative, except where otherwise specified, shall provide free of charge subject to the provisions of Sub-clause (e) of this clause; electricity, fuel and water, as may be reasonably demanded to carry out such tests efficiently.
- e) If any portion of the works fail to pass the tests, tests of the said portion shall, if required by the Engineer/ Company or by the Contractor, be repeated within a reasonable time upon the same terms and conditions, as aforesaid, save that all expenses to which the Company Representative may be put by the repetition of the tests shall be deducted from the Contract Price.

27. Inspection of Completed Works:

- a) The Contractor is required to give the Company Representative/Engineer due notification when he expects the work to be completed, a report in triplicate of the measurements carried out with regard to pressure testing of pipes and leak testing of duct work and other specified tests shall be attached to this application. The final inspection should then be carried out, without unnecessary delay, and if possible within four weeks.
- b) At the request of either party, inspection of such Sections of the work as will not be accessible after completion, or will be difficult to alter, which are to be taken into use by the Company Representative before the time of the final inspection, may be carried out in advance. (Advance Inspection).
- c) An inspection is to be carried out immediately before the expiry of the guarantee period. (Guarantee Inspection).
- d) Inspection of corrected faults or omissions noted in connection with advance, final, or guarantee inspection is also to be done (Supplementary Inspection).
- e) Inspections are to be carried out by the Engineer/ Company or any other suitable and competent person appointed by the Company Representative.

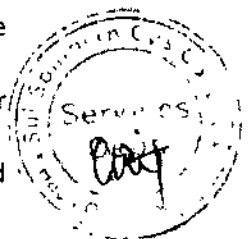

SPECIFICATIONS

PROJECT NO : 1890
PROJECT TITLE : SSGCL HEAD OFFICE BUILDING, KARACHI
DATED : 20TH APRIL, 2026

- f) The costs of Advance Inspection, Final Inspection & Guarantee Inspection are to be met by the Company Representative, where the inspection has been carried out by a person appointed by him.
- g) The costs of supplementary inspections and re-inspections are to be borne by the Contractor.
- h) It is the responsibility of the Contractor to provide & pay for, any help or assistance necessary in connection with the inspection work.
- i) The inspector's decision as to what faults or omissions may have occurred is binding on both sides.
- j) The Contractor is required to carry out, without delay, any improvements, alterations or additions which may be considered necessary as the result of an inspection report.
- k) When the final inspection has taken place, the work is to be handed over to the Company Representative in so far as has been found to be in the state required by the Contract, and can suitably be put into use for this purpose for which it was intended.
- l) The Company Representative has the right to put into use any Section of the work contracted for and not approved at the time of inspection, provided this can be done without jeopardising the progress of the work, and he may use it without special compensation even before the faults or omissions have been made good.
- m) Where special dates are specified under the Contract for the completion of different Sections of the work, the provisions of this Clause are to apply to each part separately.
- n) The inspection report required under this Clause is to be delivered in writing, and signed by the inspector, giving the date on which it is to be made available for the parties' inspection. The report should cover the following points:
 - i) State whether the work has been approved or not.
 - ii) State the reasons for failing to approve it, if it has not been approved.
 - iii) State faults or omissions for which the Contractor is to be held responsible, together with the time within which they are to be made good.
 - iv) Include notes on matters which do not require immediate action, but ought to be finally settled in connection with the guarantee inspection.
 - v) The sum to which the Company Representative is entitled.
 - vi) Date on which the insurance taken out by the Contractor lapses.
 - vii) If the work has been approved at the final inspection, the date from which the guarantee/maintenance period is to run and the day after which it expires.
 - viii) Distribution of costs connected with the inspection.

28. Acceptance & Interim Operation:

- a) After the performance tests, if the equipment supplied by the Contractor is found to meet the guarantee and any other specified requirement, and if all other work called for hereunder has been completed, the Company Representative's acceptance will be forthcoming and final payment will become due as provided for under the terms of payment. This acceptance shall, however, not relieve the Contractor of his responsibility for the first inspection.
- b) Should the equipment furnished by the Contractor fail to operate as required, or in case of failure to meet any of its guarantees, the Company Representative shall have the right to operate the equipment, using the Contractor's supervisory operating personnel, until such defects have been remedied and guarantees met with. In the event that defects necessitate the rejection of the equipment or any part thereof, the Company Representative shall have the right to operate the equipment until such time as new



SPECIFICATIONS

PROJECT NO : 1890
PROJECT TITLE : SSGCL HEAD OFFICE BUILDING, KARACHI
DATED : 20TH APRIL, 2026

equipment is provided to replace the rejected equipment. Such operation shall not be deemed as an acceptance of any equipment.

29. Inspection & Testing During Manufacture:

- a) The Engineer/ Company shall be entitled at all responsible times during manufacture to inspect, examine and test on the Contractor's premises the materials and workmanship of all plant to be supplied under the Contract, and if part of the said plant is being manufactured on another premises the Contractor shall obtain the Engineer/ Company permission to inspect, examine & test as if the said plant were being manufactured on the Contractor's premises. Such inspections, examination or testing if made shall not release the Contractor from any obligation under the Contract.
- b) The Contractor shall give to the Engineer/ Company reasonable notice in writing of the date and place at which the plant will be ready for testing as provided in the Contract, and unless the Engineer/ Company shall attend at the place so named within ten days of the date which the Contractor has stated in his notice, the Contractor may proceed with the test and also get the inspection and test carried out by an international testing agency of repute in the country of manufacture of the plant and thereafter forward to the Engineer/ Company duly certified copies of the test report carried out by him and the international inspecting agency, who on basis thereof give his opinion/decision. Provided that the Engineer/ Company shall give the Contractor twenty four hours notice in writing of his intention to attend the test.
- c) Where the Contract provides for tests on the premises of any Sub-Contractor, the Contractor shall provide such assistance, labour, materials, electricity, fuel, stores, apparatus and instruments as may be requisite and as may be reasonably demanded to carry out such tests efficiently.
- d) As and when any Plant shall have passed the tests referred to in this Clause the Engineer/ Company shall furnish to the Contractor a certificate in writing to that effect.

END OF SECTION 23 05 01



PROJECT NO : 1890
 PROJECT TITLE : SSGCL HEAD OFFICE BUILDING, KARACHI
 DATED : 20TH APRIL, 2026

BASIC MECHANICAL MATERIALS AND METHODS

PART-1: GENERAL

1.1 Related Documents:

Drawings and general provisions of Contract, including General and Special Conditions apply to this Section.

1.2 Summary:

This Section includes the following basic mechanical materials and methods to complement other Division 15 Sections.

- a) Piping materials and installation instructions common to most piping systems.
- b) Nonshrink grout for equipment installations.
- c) Field-fabricated metal and wood equipment supports.
- d) Installation requirements common to equipment specification sections.
- e) Mechanical demolition
- f) Cutting and patching
- g) Touch-up painting and finishing

1.3 Definitions:

- a) Pipe and pipe fitting materials are specified in piping system Section.
- b) Equipment and installation shall be in compliance with ANSI/ASHRAE 15 (latest edition).
- c) Pipe, pipe fittings and piping include tube, tube fittings and tubing.
- d) Finished spaces: Spaces other than mechanical and electrical equipment rooms, furred spaces, pipe and duct shafts, spaces above ceiling, crawl spaces and tunnels.
- e) Exposed Interior Installations: Exposed to view indoors. Examples include finished occupied spaces and mechanical equipment rooms.
- f) Exposed Exterior Installations: Exposed to view outdoors, or subject to outdoor ambient temperatures and weather conditions. Examples include rooftop locations.
- g) Concealed Interior Installations: Concealed from view and protected from physical contact by building occupants. Examples include above ceilings and in duct shafts.

1.4 Submittals:

1.4.1 Tendering Stage Submittals

Tenderer shall submit the following documentation:

- a) Equipment catalogue having specifications, selection data; equipment dimensions, etc.
- b) Factory computer selection.
- c) Equipment Quality Assessment Form supplied by the Engineers, dully filled.
- d) Statement of deviation from specifications.

1.4.2 Technical Approval Stage Submittals

Contractor shall submit the following documentation and obtain Engineers approval prior to ordering the equipment:

- a) Equipment catalogue;
- b) Factory computer selection;



SPECIFICATIONS

PROJECT NO : 1890
PROJECT TITLE : SSGCL HEAD OFFICE BUILDING, KARACHI
DATED : 20TH APRIL, 2026

- c) Electrical control panel diagram and information
- d) Microprocessor control panel information
- e) Crating information
- f) Shipment information;
- g) Utility requirements;
- h) Statement of deviation from specifications.

1.4.3 Construction Stage Submittals

Contractor shall submit the following documentation at appropriate times:

- a) Certified dimensional drawings of the equipment.
- b) Equipment Installation Manual.
- c) Field Wiring Diagram.
- d) Factory Performance Test Protocol

1.4.4 Close-Out Submittals

Contractor shall submit the following documentation at the closeout of the project:

- a) Commissioning Reports, as per manufacturer's standard, duly signed by the commissioning engineer.
- b) 5 sets of operation & maintenance manual.
- c) 5 sets of spare parts manual.

1.5 Quality Assurance:

1.5.1 Standard & Regulatory Requirements

- a) Qualify welding processes and operators for structural steel according to AWS D1.1 "Structural Welding Code - Steel."
- b) Qualify welding processes and operators for piping according to ASME "Boiler and Pressure Vessel Code", Section IX, "Welding and Brazing Qualifications."
 - i) Comply with provisions of ASE B31 Series "Code for Pressure Piping."
 - ii) Certify that each welder has passed AWS qualification tests for the welding processes involved and that certification is current.
- c) ASME A13.1 for lettering size. Length of color field, colors and viewing angles of identification devices.
- d) Equipment Selection: Equipment of greater or larger power, dimensions, capacities and ratings may be furnished, provided such proposed equipment is approved in writing and connecting mechanical and electrical services, circuit breakers, conduit, motors bases and equipment spaces are increased. No additional costs will be approved for these increases, if larger equipment is approved. If minimum energy ratings or efficiencies of the equipment are specified, the equipment must meet the design requirements and commissioning requirements.
- e) For products manufactured for 50 Hz use, that do not carry or qualify for UL labels, a manufacturer's certification is required that the product meets the minimum requirements of Internationally Recognized Testing Laboratories (IRTL) meeting the requirements of International Electro Commission (IEC), which are deemed equal to UL and other U.S. testing laboratories.

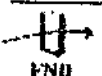

SPECIFICATIONS

PROJECT NO : 1890
PROJECT TITLE : SSGCL HEAD OFFICE BUILDING, KARACHI
DATED : 20TH APRIL, 2026

1.6 Delivery, Storage and Handling:

- a) Deliver pipes and tubes with factory-applied end-caps. Maintain end-caps through shipping, storage, and handling to prevent pipe-and damage and prevent entrance of dirt, debris and moisture.
- b) Protect stored pipes and tubes from moisture and dirt. Elevate above grade. When stored inside, do not exceed structural capacity of the floor.
- c) Protect flanges, fittings and piping specialties from moisture and dirt.

1.7 Sequencing and Scheduling:

- a) Coordinate mechanical equipment installation with other building components.
- b) Arrange for chases, slots and openings in building structure during progress of construction, to allow for mechanical installations.
- c) Coordinate the installation of required supporting devices and set sleeves in poured-in-place concrete and other structural components, as they are constructed.
- d) Sequence, coordinate and integrate installations of mechanical materials and equipment for efficient flow of the work. Coordinate installation of large equipment requiring positioning prior to closing in the building.
- e) Coordinate connection of mechanical systems with utilities and services. Comply with requirements of governing regulations, service companies, and Engineers.
- f) Coordinate requirements for access panels and doors where mechanical items requiring access are concealed behind finished surfaces.
- g) Coordinate installation of identifying devices after completion of covering and painting, where devices are applied to surfaces. Install identifying devices prior to installation of acoustical ceilings and similar concealment.

1.8 Shop Drawings:

- a) Shop drawing detailing fabrication and installation for metal and wood supports and anchorage for mechanical materials and equipment.
- b) Coordination drawings for access panel and door locations.
- c) Prepare coordination drawings to a 1:50 scale or larger. Detail major elements, components and systems of mechanical equipment and materials in relationship with other systems, installations and building components. Show space requirements for installation and access. Show where sequence and coordination of installations are important to the efficient flow of the work. Include the following:
 - i) Proposed locations of piping, ductwork, equipment and materials. Include the following:
 - Planned piping layout, including valve and specialty locations and valve stem movement.
 - Planned duct systems layout, including elbows radii and duct accessories.
 - Clearances for installing and maintaining insulation.
 - Clearances for servicing and maintaining equipment, including space for equipment disassembly required for periodic maintenance.
 - Equipment services connections and support details.
 - Wall penetrations.
 - Fire-rated wall and floor penetrations.
 - Sizes and location of required concrete pads and bases.



SPECIFICATIONS

PROJECT NO : 1890
PROJECT TITLE : SSGCL HEAD OFFICE BUILDING, KARACHI
DATED : 20TH APRIL, 2026

- ii) Scheduling, sequencing, movement and positioning of large equipment into the building during construction.
- iii) Floor plans, elevations and details to indicate penetrations in floors, walls and ceilings and their relationship to other penetrations and installations.
- iv) Reflected ceiling plans to coordinate and integrate installations, air outlets, and inlets, light fixtures, communications systems components, sprinklers and other ceiling-mounted items.

1.9 Warranty:

Manufacturer shall guarantee the equipment against defects in materials and/or workmanship for a period of one year from date of initial operation or 18 months from data of shipment, whichever occurs first, unless otherwise stated elsewhere in this document.

PART-2: PRODUCTS

2.1 General:

2.1.1 Pipe and Pipe Fittings

- a) Refer to individual piping system specification Sections for pipe and fitting materials and jointing methods.
- b) Pipe Threads: ASME B1.20.1 for factory-threaded pipe and pipe fittings.

2.1.2 Joining Materials

- a) Refer to individual piping systems specification Sections in Division 15 for special joining materials not listed below.
- b) Pipe Flange Gasket Materials: Suitable for the chemical and thermal conditions of the piping system contents.
 - 1. ASME B16.21, non-metallic, flat, asbestos-free, 3.2mm maximum thickness, except where thickness or specific material is indicated.
 - i) Full-Face Type: For flat-face, Class 125 cast-iron and cast-bronze flanges.
 - ii) Narrow-Face Type: For raised-face, Class 250 cast-iron and steel flanges.
 - 2. ASME B16.20 for grooved, ring-joint, steel flanges.
 - 3. AWWA C110, rubber, flat face, 3.2mm thick, except where other thickness is indicated; and full-face or ring type, except where type is indicated.
- c) Flange Bolts and Nuts: ASME B18.2.1 Carbon steel, galvanised, except where other material is indicated.
- d) Solder Filler Metal: ASTM B 32.
 - 1. Alloy Sn95 or Alloy Sn94: Tin (approximately 95 percent), and silver (approximately 5%), having 0.10-percent lead content.
- e) Brazing Filler Metals: AWS A5.8.
 - 1. BA91: Silver alloy.
- f) Welding Filler Metals: Comply with AWS D10.12 for welding materials appropriate for wall thickness and chemical analysis of steel pipe being welded.
- g) Flanged, Ductile-Iron Pipe Gasket, Bolts and Nuts: AWWA C110, rubber gasket, carbon steel bolts and nuts.

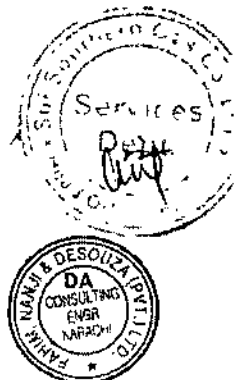
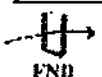

SPECIFICATIONS

PROJECT NO : 1890
PROJECT TITLE : SSGCL HEAD OFFICE BUILDING, KARACHI
DATED : 20TH APRIL, 2026

2.1.3 Piping Specialties

- a) Escutcheons: Manufactured wall, ceiling and floor plates; deep-pattern type, where required to conceal protruding fittings and sleeves.
 - i) Inside Diameter: Closely fit around pipe, tube and insulation of insulated piping.
 - ii) Outside Diameter: Completely cover opening,
 - iii) Cast Brass: One-piece, with set-screw, with chrome plated finish.
 - iv) Cast-Iron Floor Plate: One-piece casting.
 - v) Finish: Polished chrome plate.
- b) Dielectric Fittings: Assembly or fitting having insulating material isolating joined dissimilar metals, to prevent galvanic action and stop corrosion.
 - i) Description: Combination of copper alloy and ferrous; threaded, solder, plain and weld neck end types and matching piping system materials.
 - ii) Insulating Material: Suitable for system fluid, pressure and temperature.
 - iii) Dielectric Union: Factory-fabricated, union assembly, for 17.5 kg/cm² minimum working pressure at 82°C temperature.
 - iv) Dielectric Flanges: Factory-fabricated, companion-flange assembly, for 10.5 or 21 kg/cm² minimum pressure to suit system pressures.
 - v) Dielectric-Flange Insulation Kits: Field-assembled, companion-flange assembly, full-face or ring type. Components include neoprene or phenolic gasket, phenolic or polyethylene bolt sleeves, phenolic washers and steel backing washers.

Provide separate companion flanges and steel bolts and nuts for 10.5 or 21 kg/cm² minimum working pressure to suit system pressures.
 - vi) Dielectric Couplings: Galvanized-steel coupling, having inert and non-corrosive, thermoplastic lining, with threaded ends and 21 kg/cm² minimum working pressure at 197 degrees C temperature.
- c) Mechanical Sleeve Seals: Modular, watertight, mechanical type. Components include interlocking synthetic rubber links shaped to continuously fill annular space between pipe and sleeve. Connecting bolts and pressure plates cause rubber sealing elements to expand when tightened.
- d) Sleeves: The following materials are for wall, floor, slab and roof penetrations:
 1. Steel Pipe: ASTM A 53, Type E, Grade A, Schedule 40, galvanized, plain ends or BS 1387 (medium grade).
 2. Wall Penetration Systems: Wall sleeve assembly, consisting of housing, gaskets and pipe sleeve, with 1 mechanical-joint and conforming to AWWA C110 and 1 plain pipe-sleeve end.
 - i) Penetrating Pipe Deflection: 5 percent without leakage.
 - ii) Housing: Ductile-iron casting having waterstop and anchor ring, with ductile-iron gland, steel studs and nuts and rubber gasket conforming to AWWA C111, of housing and gasket size as required to fit penetrating pipe.
 - iii) Pipe Sleeve: AWWA C151, ductile-iron pipe.
 - iv) Housing-to-Sleeve Gasket: Rubber or neoprene, push-on type of manufacturer's design.

SPECIFICATIONS

PROJECT NO : 1890
PROJECT TITLE : SSGCL HEAD OFFICE BUILDING, KARACHI
DATED : 20TH APRIL, 2026

3. Cast-Iron Sleeve Fittings: Commercially made, sleeve having integral clamping flange, with clamping ring, bolts and nuts for membrane flashing.

2.1.4 Grout

Nonshrink, Non-metallic Grout: ASTM C 1107, Grade B.

- i) Characteristics: Post-hardening, volume-adjusting, dry hydraulic-cement grout, nonstaining, no corrosive, nongaseous and recommended for interior and exterior applications.
- ii) Design Mix: 350 kg/cm², 28-day compressive strength.
- iii) Packaging: Premixed and factory-packaged.

2.1.5 Spares

Provide spares as indicated under EQUIPMENT DATA SHEET.

PART-3: EXECUTION

3.1 Foundation:

Equipment shall generally be installed on concrete foundations constructed by others. This contractor shall supply dimensional drawings of the foundation, suitable to accommodate the equipment, in accordance with the manufacturer's recommendations.

3.2 Piping Systems – Common Requirements:

- a) General: Install piping as described below, except where system Sections specify otherwise. Individual piping system specification Sections in Division 15 specify piping installation requirements unique to the piping systems.
- b) General Locations and Arrangements: Drawings (plans, schematics and diagrams) indicate general location and arrangement of piping systems. Indicated locations and arrangements were used to size pipe and calculate friction loss, expansion, pump sizing and other design considerations. Install piping as indicated, except where deviations to layout are approved on coordination drawings.
- c) Install all piping with slopes to provide low point drainage.
- d) Install components having pressure rating equal to or greater than system operating pressure.
- e) Install piping in concealed interior and exterior location, except in equipment rooms and service areas.
- f) Install piping free of sags and bends.
- g) Install exposed interior and exterior piping at right angles or parallel to building walls. Diagonal runs are prohibited.
- h) Install piping tight to slabs, beams, joists, columns, walls and other building elements. Allow sufficient space above removable ceiling panels to allow for ceiling panel removal.
- i) Install piping to allow application of insulation plus 25mm clearance around insulation.
- j) Locate groups of pipes parallel to each other, spaced to permit valve servicing.
- k) Install fittings for changes in direction and branch connections.
- l) Install couplings according to manufacturer's printed instructions.
- m) Install pipe escutcheons for all pipe penetrations of concrete and masonry walls, wall board partitions and suspended ceilings.
- n) Install sleeves for all pipes passing through concrete and masonry walls, gypsum-board partitions, and concrete floor and roof slabs.



SPECIFICATIONS

PROJECT NO : 1890
PROJECT TITLE : SSGCL HEAD OFFICE BUILDING, KARACHI
DATED : 20TH APRIL, 2026

- i) Cut sleeves to length for mounting flush with both surfaces. Exception; Extend sleeves installed in floors of mechanical equipment areas or other wet areas 10mm above finished floor level, unless otherwise indicated on drawings.
- ii) Build sleeves into any new walls and slabs as work progresses.
- iii) Install large enough sleeves to provide 6mm annular clear space between sleeve and pipe or pipe insulation.
 1. Steel Pipe Sleeves: For pipes smaller than 150mm.
 2. Steel Sheet-Metal Sleeves: For pipes 150mm and larger, penetrating gypsum-board partitions.
 3. Cast-Iron Sleeve Fittings: For floors having membrane waterproofing. Secure flashing between clamping flanges. Install section of cast-iron soil pipe to extend sleeve to 50mm above finished floor level.
 - 1) Seal space outside of sleeve fittings with nonshrink, non-metallic grout.
- iv) Except for below-grade wall penetrations, seal annular space between sleeve and pipe or pipe insulation, using approved elastomeric joint sealants.
- o) Above Grade, Exterior Wall, Pipe Penetrations: Seal penetrations using sleeves and mechanical sleeve seals. Size sleeve for 25mm annular clear space between pipe and sleeve for installation of mechanical seals.
 - i) Install steel pipe for sleeves smaller than 150mm.
 - ii) Install cast-iron "wall pipes" for sleeves 150mm and larger.
 - iii) Assemble and install mechanical seals according to manufacturer's printed instructions.
- p) Fire Barrier Penetrations: Maintain indicated fire rating of walls, partitions, ceilings and floors at pipe penetrations. Seal pipe penetrations with approved fire stopping sealant material.
- q) Verify final equipment locations for roughing-in.
- r) Piping Joint Construction: Join pipe and fittings as follows and as specifically required in individual piping system specification Sections
 - i) Ream ends of pipes and tubes and remove burrs. Bevel plain ends of steel pipe.
 - ii) Remove scale, slag, dirt and debris from inside and outside of pipe and fittings before assembly.
 - iii) Soldered Joints: Construct joints according to AWS "Soldering Manual", Chapter 22 "The Soldering of Pipe and Tube".
 - iv) Threaded Joints: Thread pipe with tapered pipe threads according to ASME B1.20.1. Cut threads full and clean using sharp dies. Ream thread pipe ends to remove burrs and restore full inside diameter. Join pipe fittings and valves as follows:
 1. Note the internal length of threads in fittings or valve ends and proximity of internal seat or wall, to determine how far pipe should be threaded into joint.
 2. Apply appropriate tape or thread compound to external pipe threads (except where dry seal threading is specified).
 3. Align threads at point of assembly.
 4. Tighten joint with wrench. Apply wrench to valve end into which pipe is being threaded.
 5. Damaged Threads: Do not use pipe or pipe fittings having threads that are corroded or damaged. Do not use pipe section that have cracked or open welds.



SPECIFICATIONS

PROJECT NO : 1890
PROJECT TITLE : SSGCL HEAD OFFICE BUILDING, KARACHI
DATED : 20TH APRIL, 2026

- s) Piping Connections: Except as otherwise indicated make piping connections as specified below.
- Install unions, in piping 50mm and smaller, adjacent to each valve and at final connection to each piece of equipment having 50mm or smaller threaded pipe connection.
 - Install flanges, in piping 60mm and larger, adjacent to flanged valves and at final connection to each piece of equipment having flanged pipe connection.
 - Dry Piping Systems (Gas): Install dielectric unions and flanges to connect piping materials of dissimilar metals.
 - Wet Piping Systems (Water): Install dielectric coupling and nipple fittings to connect piping materials of dissimilar metals.

3.3 Direction of Metal Supports and Anchorage:

- Cut, fit and place miscellaneous metal supports accurately in location, alignment and elevation to support and anchor mechanical materials and equipment.
- Field Welding: Comply with AWS D1.1 "Structural Welding Code-Steel".

3.4 Demolition:

- Disconnect, demolish and remove work specified under Division 15 and as indicated.
- Where pipe, ductwork, insulation or equipment to remain is damaged or disturbed, remove damaged portions and install new products of equal capacity and quality.
- Accessible Work: Remove indicated exposed pipe and ductwork in its entirety.
- Removal: Remove all demolished materials and equipment from the project site.
- Temporary Disconnection: Remove, store, clean, reinstall, reconnect and make operational equipment indicated for temporary or permanent relocation.

3.5 Cutting and Patching:

- Cut, channel, chase and drill floors, walls, partitions, ceilings and other surfaces necessary for mechanical installations. Perform cutting by skilled mechanics of the trades involved. Obtain prior approval of Engineer before performing work.
- Repair cut surfaces to match adjacent surfaces.

3.6 Grouting:

- Install non-metallic, nonshrink, grout for mechanical equipment base bearing surfaces, pump and other equipment base plates and anchors. Mix grout according to manufacturer's printed instructions.
- Clean surfaces that will come into contact with grout.
- Provide forms for placement of grout, as required.
- Avoid air entrapment when placing grout.
- Place grout, completely filling equipment bases.
- Place grout on concrete bases to provide a smooth bearing surface for equipment.
- Place grout around anchors.
- Cure placed grout according to manufacturer's printed instructions.

3.7 Cleaning:

Remove labels after work is complete.

Remove all splashed paint, cement splatter, protective paper, etc after work is complete, & deliver chiller in clean condition.

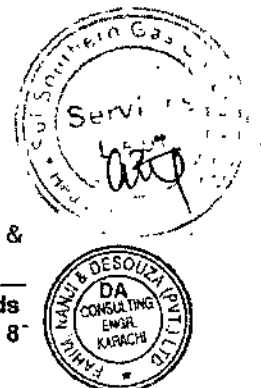

SPECIFICATIONS

PROJECT NO : 1890
PROJECT TITLE : SSGCL HEAD OFFICE BUILDING, KARACHI
DATED : 20TH APRIL, 2026

3.8 Protection of Finished Work:

Protect all equipment & work from deterioration from any condition, till handing over.

3.9 Installation Contractor's Responsibilities:

- a) Install equipment to provide the maximum possible headroom, where mounting heights are not indicated.
- b) Install equipment according to approved submittal data. Portions of the work are shown only in diagrammatic form. Refer conflicts to the Engineer.
- c) Install equipment level and plumb, parallel and perpendicular to other building systems and components in exposed interior spaces, except where otherwise indicated.
- d) Install mechanical equipment to facilitate servicing, maintenance and repair or replacement of equipment components. Connect equipment for ease of disconnecting, with minimum of interference with other installations. Extend grease fittings to an accessible location.
- e) Install equipment giving right-of-way to piping systems installed at a required slope.

3.10 Reference Specification:

The following specifications shall be construed to be part of these specifications.

- 23 05 01 - Basic Mechanical Requirement
- 23 05 02 - Basic Mechanical Materials and Methods
- 23 05 10 - Equipment Installation
- 23 05 13 - Motors
- 23 05 29 - Supports & Anchors
- 23 05 48 - Vibration Isolation Control
- 23 05 50 - Painting & Coating
- 23 05 53 - Mechanical Identification

END OF SECTION 23 05 02



SPECIFICATIONS

PROJECT NO : 1890
PROJECT TITLE : SSGCL HEAD OFFICE BUILDING, KARACHI
DATED : 20TH APRIL, 2026

EQUIPMENT INSTALLATION

The Contractor shall install equipment as & where shown on the drawings and shall perform the following work.

1. Equipment Foundation Bases:

- A. Unless otherwise indicated on drawings, equipment shall generally be installed on a 100mm to 150mm high concrete base. Base shall be constructed of 1:2:4 (210 kg/cm², 28 day compressive strength) approved concrete with nominal reinforcement. Base shall be finished with 5mm cement plaster, or approved tiles as shown on drawings. Edges shall be provided with 25x25x3mm galvanized angle iron frame work. Base dimension shall not be less than 100mm larger in both directions than supported equipment. Manufacturer's supported recommendation shall be followed, using anchor bolts at tie-in locations. Drawings shall be submitted to the Engineer for approval.

2. Lifting & Shifting Equipment onto Foundations:

- A. The contractor shall be solely responsible for safe lifting of the equipments from place of storage on site to location of final installation and finally on the foundations.
- B. Prior to lifting the equipments the following procedure shall be adopted:
1. Submit comprehensive insurance policy for the full value of the equipment to the Engineer/Company Representative from approved insurance company.
 2. Submit complete information of specialist firm of lifters/riggers to the Engineer & obtain approval.
 3. Submit complete procedure & equipment to be used for lifting the equipment in place. Identify on plans location of tripods, hoist, etc. that will transfer weight to the equipment, to the structure & obtain approval.
 4. All the above to be completed with one month before the date of lifting of equipment.

3. Equipment Installation Responsibility:

- A. The Contractor shall ensure that the equipment is installed totally in accordance with the manufacturer's instructions (equipment installation manual must be obtained & read), and as directed by the Engineer. Correct alignment & levelling must be ensured.
- B. Field assemble equipment (if required) in accordance with instructions in the manufacturer's installation bulletin.
- C. Install the equipment on the foundation. Neoprene isolation pads or spring vibration isolators as specified for the equipment shall be placed under the equipment.
- D. Insure that structure, piping or other equipment adjacent to this equipment do not restrict operation & maintenance requirements of the equipment.
- E. Install all piping, cable, and other connections with all fittings, to the equipment. All material and labor required for a complete installation shall be supplied by the Contractor.
- F. Connect equipment control panel to all operating external safety and auxiliary control devices.
- G. Provide and install gauge cocks and thermometer wells for temperature and pressure readings at the inlet and outlet of all fluid flows.
- H. Provide and install a flow switches on water circuits wherever necessary, and interlock it with the starting control circuit of the unit.
- I. Install any control components provided by the manufacturer for installation external to the machine.

END OF SECTION 23 0510



PROJECT NO : 1890
PROJECT TITLE : SSGCL HEAD OFFICE BUILDING, KARACHI
DATED : 20TH APRIL, 2026

PIPE WELDING

1. Fabrication Requirements:

A. End Preparation

1. Butt welding ends shall be bevelled. Beveling shall be done by grinding or machining and the finished bevel shall be free of nicks or grooves. Prior to welding, the bevelled surface and the adjacent surface within 6mm of the weld joint shall be cleaned of all foreign material, rust loose mill scale etc., before being placed in alignment for welding.

B. Weld Joint Alignment

1. The parts to be welded shall be aligned by suitable means such as external clamps, yokes etc. Yokes, if used, shall be tack welded using electrodes compatible with the parent metal. After joint fit-up yokes shall be ground flush.
2. Tack welding shall be done by qualified welders only and shall conform to the quality of root weld.

C. Nozzles and Piping

1. Pipes below Ø 25mm shall be cut by pipe cutter only. flame cutting is not allowed. Larger sizes may be flame cut provided edges are prepared by grinding or machining, after cutting.
2. Bolt holes shall straddle the axis of pipe for all flanged connections.
3. The center line of branch connections shall intersect the centre line of the header.

2. Welding:

A. Welder Qualification

1. Welding shall be carried out by qualified welders. Welder qualification shall be carried out in accordance with ASME Section IX Welding & Brazing Qualifications.
2. The Contractor shall provide all material, consumables and labour needed for welder qualification tests. The Contractor shall also arrange and pay for all the test required at a testing facility acceptable to the Owner.

B. Production Welding Requirements

1. All production welding including repair welding shall be carried out according to qualified welding procedures and by qualified welders only. The Owner reserves the right, at any time, to make changes in the welding procedure to ensure production of acceptable welds.
2. Scale and slag shall be removed from each weld bead and groove before depositing the next weld bead. Cleaning shall be done by power grinders and wire brushes.
3. Fillet welding shall be done for reinforcing pads, sockets welding fittings and slip-on flanges. Fillet welds shall be continuous, unless otherwise specified in the drawings. Size of fillet welds shall be as indicated on the drawings. Where no size is given, it shall be equal to the thickness of the thinner of the two parts being welded.
4. Arc burns shall be removed by grinding. Grinding shall have a smooth contour. After grinding, the remaining wall thickness in the area shall not be less than 90% of the nominal wall thickness.

3. Inspection and Testing:

- A. Hydrostatic Testing:** The piping shall be tested with water and all welds carefully inspected for leaks. The pressure shall be raised slowly and steadily until test pressure is reached. The pressure shall be maintained while a thorough examination is made to ensure that all welding are sound and show no leaks or undue distortion.



SPECIFICATIONS

PROJECT NO : 1890
PROJECT TITLE : SSGCL HEAD OFFICE BUILDING, KARACHI
DATED : 20TH APRIL, 2026

- B. **Repairs & Welds:** Defective welds found during pressure test shall be cut out for a distance of not less than 25mm on either side of the defect and shall be rewelded.
- C. **Repeat Pressure Test:** Following the execution of any repairs found to be necessary, the piping shall again be tested in accordance with the above specs.
- D. **Record:** Contractor shall keep a record of all tests performed and shall record the date of test, test conditions and results. These reports shall be signed by the Owner's representative and Contractor's representatives.

Contractor shall provide all material and labour required for testing.

END OF SECTION 23 05 11



SPECIFICATIONS

PROJECT NO : 1890
PROJECT TITLE : SSGCL HEAD OFFICE BUILDING, KARACHI
DATED : 20TH APRIL, 2026

ELECTRIC MOTORS

PART-1: GENERAL

1.1 Section Scope:

- A. These specifications apply to all motors installed on all equipment on the project and are over-ruled by relevant specifications for motors given in other Sections & EQUIPMENT DATA SHEET.
- B. This Section includes requirements for single and three phase motors that are used with equipment specified in other Sections.
- C. Commissioning & Testing.

1.2 Submittals:

- A. Tendering Stage Submittals
 1. Brands of motors to be indicated & country of origin.
- B. Construction Stage Submittals
 1. Motor catalogue.
 2. Conformance statement to these specifications.
- C. Close-Out Submittals
 1. Commissioning Reports, as per manufacturer's standard, duly signed by the commissioning engineer.

1.3 Reference Standards:

- A. IEC Electric Motor Standards
- B. ANSI/IEEE 112 Test Procedure for Polyphase Induction Motors and Generators
- C. ANSI/NEMA MG-1 Motors and Generators

1.4 Reference Specifications:

- A. The following specifications shall be construed to be part of this Section.
 1. 23 05 01 - Basic Mechanical Requirement

1.5 Quality Assurance:

- A. Standard & Regulatory Requirements
 1. Equipment manufacturer shall be a company specializing in manufacture, assembly, and field performance of motors with a minimum of ten (10) years experience.
- B. Factory Test
 1. Manufacturer's standard factory test shall be carried out as per standards specified at clause 1.3.

1.6 Delivery, Storage, and Handling:

- A. Motors shall be stored and handled in accordance with the manufacturer's recommendations.
- B. Protect motors from entry of foreign material, dust, water & falling objects. Motor shall be kept encased in protective polythene until commissioning stage.



SPECIFICATIONS

PROJECT NO : 1890
PROJECT TITLE : SSGCL HEAD OFFICE BUILDING, KARACHI
DATED : 20TH APRIL, 2026

1.7 Warranty:

- A. Manufacturer shall guarantee the motor against defects in materials and/or workmanship for a period as stated in Section-300, Conditions of Particular Application/Contract Data.

1.8 Electrical Coordination:

- A. Engineer drawings and/or specifications show horsepower rating of all motors. Should any discrepancy in size, horsepower rating, electrical characteristics or means of control be found for any motor or other electrical equipment after contracts are awarded, Contractor is to immediately notify the Engineer of such discrepancy.
- B. Costs involved in any minor changes required due to re-sizing of motor will be the responsibility of this contractor.
- C. All starters, overload relays, heater coils, disconnect switches and fuses, relays, wire, conduit, pushbuttons, pilot lights, and other devices required for the control of motors or electrical equipment shall be furnished and installed by this Contractor, except as specifically noted elsewhere in Specifications/BOQ.
- D. This Contractor will provide all power wiring and control wiring, unless otherwise specified in the BOQ.
- E. Furnish project specific wiring diagrams to Electrical Contractor for all equipment and devices furnished by this Contractor and indicated to be wired by the Electrical Contractor.

PART-2: PRODUCTS

2.1 General:

- A. Motors to conform to all applicable requirements of standards indicated in Clause 1.3 and shall be listed by U.L. for the service specified, where so indicated in other Sections.
- B. Select motors for conditions in which they will be required to perform; i.e., general purpose, splash proof, explosion proof, standard duty, high torque or any other special type as required by the equipment or motor manufacturer's recommendations or indicate in EQUIPMENT DATA SHEET.
- C. All motors shall be to IP55, and be rated at least at 125% of rated shaft power.
- D. The motors shall be suitable and able to give required output under site conditions i.e. maximum ambient temperature of 120°F (50°C) and altitude indicate in EQUIPMENT DATA SHEET.
- E. The motors shall be tropicalised, with insulation class as indicated in EQUIPMENT DATA SHEET.
- F. Motors rated 25 HP and above shall be fitted with thermistors in the three phase windings, along with a suitable relay in the MCC to trip the starter if the motor overheats.
- G. Motors for Cooling Towers shall be purpose built for cooling tower application, & shall be totally enclosed with air-overcooling.

2.2 Motor Efficiency:

- A. The energy efficiency classes of motor shall be in accordance with IEC 60034-30 as follows:
- 0.75 kW to 375 kW - Efficiency Class IE3.
 - 0.75 kW to 375 kW - at least Efficiency Class IE2 in combination with variable speed control.

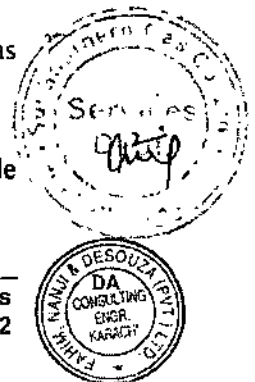

SPECIFICATIONS

PROJECT NO : 1890
PROJECT TITLE : SSGCL HEAD OFFICE BUILDING, KARACHI
DATED : 20TH APRIL, 2026

2.3 Three Phase, Single Speed Motors:

- A. All motors shall be NEMA rated for 400 volt, three phase, 50 Hertz motors for all motors 1/2 HP and larger unless specifically indicated and shall be suitable for operation at $400V \pm 10\%$.
- B. Use NEMA continuous duty, normal starting torque, with Class F. Use totally enclosed fan-cooled, motors unless otherwise specified in EQUIPMENT DATA SHEET.
- C. Use grease lubricated anti-friction ball bearings with housings equipped with plugged/capped provision for relubrication, rated for minimum AFBMA 9, L-10 life of 50,000 hours. Calculate bearing load with NEMA minimum V-belt pulley with belt center line at the end of NEMA standard shaft extension. Stamp bearing sizes on nameplate.
- D. For motors located in contaminated air stream, furnish epoxy sealed or coated motor windings & protect rotor & stator surfaces with epoxy enamel.
- E. All motors shall have a 1.15 service factor.

2.4 Single Phase, Single Speed Motors:

- A. Use NEMA rated 230 volt, single phase, 50 hertz motors for all motors 3/4 HP and smaller.
- B. Use permanent split capacitor or capacitor start, induction run motors equipped with permanently lubricated and sealed ball or sleeve bearings and Class-D insulation. Service factor to be not less than 1.35.
- C. Fractional horsepower motors shall be provided with inherent over-temperature protection.

2.5 Two-Speed Motors:

- A. Unless otherwise indicated, three phase two speed motors to be two winding, variable torque and single phase motors to be capacitor start capacitor run type having two capacitors in parallel with run capacitor remaining in circuit at operating speeds.

2.6 Motors Used on Variable Frequency Drives:

- A. In addition to the requirements specified above, the motor must be suitable for use with Variable Frequency Drive as specified in EQUIPMENT DATA SHEET, including but not limited to motor cooling. Motor shall comply with NEMA MG1 Part 31 to provide windings capable to withstand up to 1600 peak Volts with a rise time of 0.1 μ s. Provide bearing protection grounding rings to bleed current from the motor shaft to the motor casing. Manufacturers: Aegis SGR, Inpro/Seal CDR, or equal Spares.

2.7 Spares:

- A. No motor spares are to be provided unless specified elsewhere.

PART-3: EXECUTION

3.1 Installation:

- A. Install motors in accordance with manufacturer recommendations.
- B. Install required power supply & earth wiring to the motors as per manufacturer's instruction.
- C. Connect motor starter to all operating external safety and auxiliary control devices.
- D. Mount motors on a rigid base designed to accept a motor, using shims if required under each mounting foot to get a secure & level installation.
- E. When motor is flexible coupled to the driven device, mount coupling to the shafts in accordance with the coupling manufacturer's recommendations. Using a dial indicator, check angular misalignment of the two shafts; adjust motor position as necessary so



SPECIFICATIONS

PROJECT NO : 1890
PROJECT TITLE : SSGCL HEAD OFFICE BUILDING, KARACHI
DATED : 20TH APRIL, 2026

that the angular misalignment of the shafts does not exceed 0.002 inches per inch diameter of the coupling hub. Again using the dial indicator, check the shaft for run-out to assure concentricity of the shafts; adjust as necessary so that run-out does not exceed 0.002 inch.

- F. When motor is connected to the driven device by means of a belt drive, mount sheaves on the appropriate shafts in accordance with the manufacturer's instructions. Use a straight edge to check alignment of the sheaves; reposition sheaves as necessary so that the straight edge contacts both sheave faces squarely. After sheaves are aligned, loosen the adjustable motor base so that the belt(s) can be added and tighten the base so that the belt tension is in accordance with the drive manufacturer's recommendations. Frequently recheck belt tension and adjust if necessary during the first day of operation and again after 80 hours of operation (Recommendation of NEBB).
- G. Verify the proper rotation of each three-phase motor as it is being wired or before the motor is energized for any reason.
- H. Lubricate all motors requiring lubrication. Record lubrication material used and the frequency of use. Include this information in the maintenance manuals.

3.2 Commissioning & Testing:

- A. The Commissioning Engineer shall subject the motor(s) to tests recommended by the manufacturer and these test reports shall be submitted to the Engineers by the Contractor in suitable test forms.

END OF SECTION 23 05 13



SPECIFICATIONS

PROJECT NO : 1890
PROJECT TITLE : SSGCL HEAD OFFICE BUILDING, KARACHI
DATED : 20TH APRIL, 2026

METERS & GAUGES

1. Thermometers:

The ranges of thermometers shall comply with the system parameters ensuring normal indication in the mid-region. Ranges much under or above the required readings shall not be acceptable, unless specifically approved by the Engineer.

A. **Pipe Thermometers:** These shall be adjustable angle type, with brass separable socket. Case shall be smooth die cast aluminium with metallic blue-black finish. Window shall be clear acrylic plastic or double strength glass, held in place with removable stainless steel caps. Tube shall have lens front with red appearing mercury tubing. Scale shall be on white background with jet black embossed figures and markings, of specified or suitable scale, in combination of °F-°C.

- ◆ Scale size:
175mm
- ◆ Stem length:
90mm up to 150mm diameter pipes
150mm above 150mm diameter pipes
- ◆ Insertion length:
65mm for 90mm stem length
125mm for 150mm stem length

B. **Duct Thermometers:** These shall be adjustable angle type and shall conform to specifications given above for pipe thermometers, except that the duct thermometer shall be supplied with 75mm OD reversible aluminium flange and perforated aluminium bulb guard. Stem insertion length shall be 300mm.

C. **Thermometer Wells:** These shall be of brass suitable for pipeline mounting. Wells for insulated piping shall be provided with extension necks compatible to insulation thickness, to allow thermometer to clear the insulation.

D. **Installation:** Thermometers shall be installed wherever shown on the drawings. Installation on both ducts and piping shall conform to the manufacturer's recommendations. On thermally insulated ducts, casing, equipment or piping, stand off mounting brackets, bases, adopters or extended tubes shall be provided. These items shall provide clearance not less than the thickness of the insulation. Thermometers shall have ranges suitable for the fluid being served.

2. Pressure Gauges:

Pressure gauges shall be of scale range as required, for service condition, graduated in both Psi and Kg/cm². On open circuit pump suction line and wherever necessary install compound gauges.

A. **Case:** shall be of cast aluminium, black finished. Ring shall be close type, chrome plated. Window shall be clear acrylic. Dial shall be white with jet black embossed figures and graduations. Pointer shall be micrometer type, black finished and red tipped. Movement shall be stainless steel, rotary type. Bourdon tube shall be phosphor bronze. Socket shall be forged brass. Accuracy shall be 1% of the scale range. Connection shall be 6mm NPT. Dial size shall be Ø 4.5 inches.

B. **Installation:** Pressure gauges shall be installed where shown on drawings. These shall be installed with ball valves to serve as gauge cocks. For pressure gauges installed on steam line, a coil siphon shall be installed. Gauges shall be screwed in so that no leakage exists, and shall be installed in a neat and workmanlike manner and the dials aligned for convenient reading.



SPECIFICATIONS

PROJECT NO : 1890
PROJECT TITLE : SSGCL HEAD OFFICE BUILDING, KARACHI
DATED : 20TH APRIL, 2026

3. Magnahelic Gauges:

- A. General: Magnahelic differential pressure gauges shall be of scale range as required for the application.
- B. Construction: Housing shall be of die cast aluminium. Test case and aluminium parts irradiate dipped to withstand 168 hours (minimum) salt spray test. Exterior finish shall be baked dry grey hammerloid. Pointer shall be red tipped of heat treated aluminium. Diaphragm shall be silicon rubber diaphragm with integrally moulded "O" ring shall be supported by front and rear plates. It shall be locked and sealed in a position with a sealing plate and retaining ring. Diaphragm motion shall be restricted to prevent damage due to over pressure. Accuracy shall be $\pm 2\%$ of full scale connection shall be 3mm NPT, dial size shall be minimum $\varnothing 100\text{mm}$.
- C. Installation: Magnahelic gauges shall be flush or surface mounted with standard hardware supplied and shall be installed as follows:
 1. At Filters: Each bank of high efficiency filter and HEPA filter shall be provided with an appropriate station to determine pressure drop, consisting of magnahelic gauge, probes, flexible tubes and mounting arrangement.
 2. At Positive or Negative Pressurised Areas: At the outside of each positive or negative pressure areas, install a magnahelic gauge to read room pressure with respect to adjoining space pressure. For this purpose probes shall be installed in the room and in the adjoining corridor/space, and connected with flexible tubing to the magnahelic gauge.
 3. As shown on drawings or as required.

END OF SECTION 23 05 19



SPECIFICATIONS

PROJECT NO : 1890
PROJECT TITLE : SSGCL HEAD OFFICE BUILDING, KARACHI
DATED : 20TH APRIL, 2026

VALVES & STRAINERS

1. Butterfly Valves:

Butterfly valves shall be used applications requiring 50mm or larger diameter valves, and shall have a rating suitable for the service intended, but a minimum of 10 bars.

Butterfly valves shall be wafer type with modular cast iron body, suitable for mounting between ANSI 150 lb flanges. Two flanges plus required nuts and bolts shall be provided with the valves.

The center disc shall be of stainless steel, with extended shaft for accommodating insulation depth.

The liner shall be replaceable, of Nitrile or EPDM rubber. Each valve shall be provided with one replaceable liner as spare.

Actuator shall be worm gear type of aluminium or cast iron, weather proof to IP65, complete with hand wheel, position indicator, and with adjustable stops at both fully open and fully closed positions. The actuator shall be self-locking, lubricated for life and free of maintenance.

2. Gate Valves:

A. Ø 50mm (2 inch) & Smaller

125 psi (860 kPa) SWP, 250°F (120°C), threaded ends, bronze body, union bonnet, non-rising stem, wedge disc. Hand wheel nut, packing nut, gland, stuffing box, bonnet, bonnet ring, disc and body shall be of bronze. Hand wheel shall be of malleable iron. Packing shall be suitable for specified usage but shall not use asbestos. Stem shall be manganese bronze.

B. Ø 65mm (2½ inch) & Larger

125 psi (860 kPa) SWP, 250°F (120°C), cast iron body bronze mounted with flanged ends. These shall be of solid wedge disc type, with outside screw and yoke (rising stem). Body and bonnet shall be of cast iron. Wedge shall be of cast iron with bronze disc. Seat rings shall be bronze. Packing shall be suitable for specified usage but shall not use asbestos. Packing gland shall be cast iron. Yoke shall be of cast iron and yoke nuts shall be of bronze. Hand wheel shall be of cast iron.

3. Globe Valves:

A. Ø 50mm (2 inch) & Smaller

125 psi (860 kPa) SWP, 250°F (120°C), bronze, threaded ends. Body, bonnet, disc holder, stem lock nut, packing nut and disc lock nut shall be of bronze. Hand wheel shall be of malleable iron with stem of manganese bronze. Renewable composition disc shall be provided suitable for water & steam. Packing shall be suitable for specified usage, but shall not use asbestos.

B. Ø 65mm (2½ inch) & Larger

125 psi (860 kPa) SWP, 250°F (120°C), cast iron body, bronze mounted with bronze faced disc and yoke bonnet, and shall be flanged. Hand wheel, gland, bonnet and body shall be of cast iron. Stem shall be of manganese bronze. Packing shall be suitable for specified usage but shall not use asbestos. Stem lock nut, disc and seat ring shall be of bronze. Disc shall be renewable composition type.

4. Ball Valves:

A. Ø 50mm (2 inch) & Smaller

125 psi (860 kPa) SWP, Screwed; two-piece cast bronze body, chrome plated brass ball, teflon ball and flange seals, rods silicon brass stem, teflon and Viton "O" ring stem seals, zinc plated carbon steel handle with vinyl grip and brass handle nut.



SPECIFICATIONS

PROJECT NO : 1890
PROJECT TITLE : SSGCL HEAD OFFICE BUILDING, KARACHI
DATED : 20TH APRIL, 2026

5. Swing Check Valves:**A. Ø 50mm (2 inch) & Smaller**

125 psi (860 kPa) SWP; 250°F (120°C), threaded ends. Cap, hinge pin, body, hinge, disc nut and disc shall be of bronze.

B. Ø 65mm (2½ inch) & Larger

125 psi (860 kPa) SWP; 250°F (120°C), cast iron body, including valve cap and disc. Hinge pin, seat ring and disc ring shall be of bronze. Ends shall be flanged.

6. Guided Check Valves:**A. Ø 80mm (3 inch) & Smaller**

125 psi (860 kPa) SWP, Screwed, (pump discharge): bronze or cast steel wafer body, bronze or stainless steel trim, centre guided, silent type.

B. Ø 100mm (4 inch) & Larger

125 psi (860 kPa) SWP, Flanged, (pump discharge): bronze or cast steel globe body, bronze or stainless steel trim, centre guided, silent type, flanged.

7. Y-Strainers:**A. Ø 50mm (2 inch) & Smaller**

125 psi (860 kPa) SWP; 250°F (120°C), "Y" type, with bronze body and threaded ends. Screen shall be of 20 mesh monel.

B. Ø 65mm (2½ inch) & Larger

125 psi (860 kPa) SWP; 250°F (120°C), cast iron body with flanged ends. Screen cover shall be provided with blow off tapping. Screen shall be of perforated stainless steel, (33 holes per sq.cm.), with 1.1mm diameter and 0.41mm thickness.

8. Bucket Strainers:

A. Shall be fabricated from Ø 300mm, Black Steel, Schedule 40 pipe. Flanges shall conform to ANSI B16.5. After fabrication the entire assembly shall be hot dipped galvanised. Bolts shall be galvanised. The strainer shall consist of a brass perforated screen bucket. Perforation shall be as approved.

9. Pressure Reducing Valves (PRV):

- A. Pressure Reducing Valves (PRV's) shall be pilot operated.
- B. PRV's shall be suitable for the service specified & shall be able to maintain downstream pressure at all flow rates & shall be sized for the maximum flow & pressure specified or required on the basis of manufacturers published data.
- C. PRV's upto Ø 40mm shall be of bronze with screwed ends, while higher size PRV's shall be of cast-iron body with flanged ends. Nominal working pressure shall be 16 barg. PRV shall be able to sustain working temperature upto 70°C (158°F). Pilot shall be adjustable for 1.4 barg to 12 barg.

10. Float Valve:

A. Shall be best quality heavy duty type provided with Ø 150mm copper ball and heavy duty bronze float arm. Valve shall provide tight shut off at full closed position.

11. Foot Valve for Pump Suction Line:

A. Shall be installed where required or indicated on the drawing. Foot valve shall be of brass, and shall be provided with integral strainer. Foot valve shall be provided with a spring loaded vertical check disc with gasket for tight shut-off.

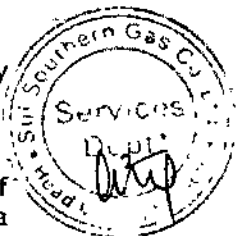

SPECIFICATIONS

PROJECT NO : 1890
PROJECT TITLE : SSGCL HEAD OFFICE BUILDING, KARACHI
DATED : 20TH APRIL, 2026

12. Gaskets:

A. **General:** non-asbestos, compressed gasket material with high-strength aramid fibres bonded with high grade nitrile NBR synthetic rubber, suitable for 750°F (400°C) and 1450 psi (10000 kPa).

13. Thread Lubricant:

A. **General:** non-hardening, non-poisonous as approved.

14. Dielectric Couplings:

A. **General:** provide sweat-to-screw dielectric couplings at junction of copper pipe to steel pipe and insulation bushings for flanged connections to steel or cast iron valves and fittings.

15. Installation of Valves and Strainers:

A. All gate valves, globe valves, check valves, control valves, butterfly valves, drain cocks, etc. necessary for satisfactory operation of the system shall be provided whether indicated or not. All valves having stem over 2m height shall be provided with galvanised chain operators. Valves in horizontal lines shall be installed with stem horizontal or above. Isolation gate valves shall be installed on each side of each piece of equipment as pumps, coils and other similar items; at the midpoint of all looped mains; and at any other points indicated or as required for draining, isolation or sectionalising purposes. Each valve shall be identified with not less than 35mm round or square black over white laminated plastic tags secured to valve with a suitable brass chain. Tags shall be engraved to identify valve by number and valve function. Strainers shall be installed wherever necessary to protect equipment and control valve, where proper functioning would be affected by dirt on the seat or scoring of the seat. Strainers shall be arranged not to clog piping and allow easy disconnection for change. All strainers 50mm and above shall be provided with Ø20mm ball valves for blow-off. Strainers shall allow removal of accumulated dirt and screen replacement without disconnecting main piping.

END OF SECTION 23 05 23



SPECIFICATIONS

PROJECT NO : 1890
PROJECT TITLE : SSGCL HEAD OFFICE BUILDING, KARACHI
DATED : 20TH APRIL, 2026

SUPPORTS & ANCHORS

PART-1: GENERAL

1.1 System Description:

- A. Furnish labour, materials, equipment, ladders, scaffolding, protective covers, other items required to prepare and finish surfaces of work specified herein or in any of the other sections.

1.2 Submittals:

- A. The contractor shall submit to the Engineer Technical Submittals and obtain Engineer's approval before proceeding to the next work stage. The submittal submission shall be a four stage process till completion of the project as noted below, and as also detailed under Section 23 05 02 - Basic Mechanical Material & Methods:

1. Tendering Stage Submittals

Bidder shall submit all required documentation to establish conformance to specifications, as indicated in Section 23 05 02, Clause 1.4, as well as any special requirements noted below.

2. Technical Approval Stage Submittals

Contractor shall submit all required documentation to establish conformance to specifications, as indicated in Section 23 05 02, Clause 1.4, as well as any special requirements noted below.

3. Construction Stage Submittals

Contractor shall submit all required documentation to establish conformance to specifications, as indicated in Section 23 05 02, Clause 1.4, as well as any special requirements noted below.

4. Close-Out Submittals

Contractor shall submit all required documentation to establish conformance to specifications, as indicated in Section 23 05 02, Clause 1.4, as well as any special requirements noted below.

1.3 Delivery, Storage, and Handling:

- A. Deliver, store & handle equipment as directed by the manufacturer and in accordance with specifications given under Section 23 05 02, Clause 1.3.

1.4 Warranty:

- A. All supports and anchors shall be guaranteed against defects in materials and/or workmanship for a period of one year from date of Substantial Completion. Galvanizing shall have extended warranty as usually offered by the support manufacturers.

PART-2: PRODUCTS

2.1 General:

- A. All pipe supports, including supporting rods, concrete fasteners, etc, shall be manufactured by specialist pipe support manufacturers, such as Hilti, Sikla, Fisher, etc as indicated in Section 23 90 10, List of Approved Manufacturers.
- B. All supports shall be Hot Dipped galvanized.
- C. Pipe hangers, brackets, saddles, inserts, clamps and pipe rolls including rods, bolts, turn buckles, bases and protection shields shall conform to standard

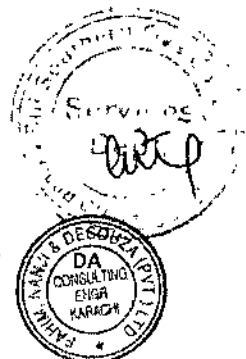

SPECIFICATIONS

PROJECT NO : 1890
PROJECT TITLE : SSGCL HEAD OFFICE BUILDING, KARACHI
DATED : 20TH APRIL, 2026

recommended engineering practice and shall be all sourced from approved manufacturers of support system.

- D. For field fabricated supports, design generally accepted as exemplifying good engineering practice, using stock or production parts shall be utilised, and drawings and samples shall have Engineers approval.
- E. Chain, wire, strap or other make shift devices will not be permitted as hangers or supports.
- F. Pipe hangers shall be capable of supporting the pipe in all conditions of operations, and shall be selected for 2 times the supported weight. Hangers shall be supported with beam-clamps, concrete inserts, Phillips concrete fasteners, or rawl-bolts. Concrete inserts when used shall be installed in the exact location prior to the pouring of the concrete.
- G. All support rods shall be fully threaded, & hot dip galvanized.
- H. Piping shall be supported by adjustable hangers or supports, which shall provide a means of vertical & horizontal adjustment after erection.

PART-3: EXECUTION

3.1 Suspended Piping Supports:

- A. Unless otherwise indicated on drawings maximum spacing between pipe supports for straight runs of copper pipe shall be in accordance with recommended spacing shown in the table given below:

	Nominal Pipe Size, Ø Inch										
	5/8	7/8	1 1/8	1 5/8	2	2 1/8	3 1/8	3 5/8	4 1/8	5 1/8	6 1/8
Maximum Span, ft	5	6	7	9	9	10	12	13	14	14	14
Rod Size, Ø inch	3/8	3/8	3/8	3/8	3/8	1/2	1/2	1/2	1/2	5/8	5/8

- B. Pipe hangers and supports shall be spaced not over 5ft apart at heavy fittings and valves. A hanger shall be installed at not over 12inch from each change in direction of piping.
- C. Vertical Piping shall be guided or supported in the centre of each riser but not over 8ft on centres and shall be supported at the base of the riser on a base elbow or tee with a pipe stand only where required.

3.2 Pipe Sleeves:

- A. Pipes passing through concrete or masonry walls or concrete floors or roofs shall be provided with pipe sleeves fitted into place at the time of construction or afterwards if necessary. Each sleeve shall extend through its respective wall, floor or roof and shall be cut flush with each surface. Sleeves shall be of such size as to provide a minimum of 6mm all around clearance between bare pipe and sleeve or between jacket over insulation and sleeve. Sleeves shall be of steel pipe or cast iron pipe.

3.3 Other Supports:

- A. Equipment and any other plant component requiring supporting and anchoring shall be provided with properly engineered supports and anchors, as shown on the drawings, or as per manufacturer's recommendation or as directed by the Engineer/company representative in all cases drawings & submittals for supports & anchor system shall be submitted to the Engineer and approval obtained.



SPECIFICATIONS

PROJECT NO : 1890
PROJECT TITLE : SSGCL HEAD OFFICE BUILDING, KARACHI
DATED : 20TH APRIL, 2026

supplied and installed by this Contractor within the cost quoted. It is the intent of these specifications to obtain a completely operational system and the Contractor shall be responsible for providing the same.

6. Commissioning and Testing:

The water treatment system shall be commissioned and tested by the Contractor to the satisfaction of the Consultants. Test reports shall be submitted by the Contractor and approval obtained. During the maintenance period, the Contractor shall be responsible to make monthly service calls, conduct water analysis and submit a report on the findings to the Client/Consultants.

7. Spares:

Provide spares in accordance with requirement given under SPARES EQUIPMENT DATA SHEET (Section 2).

8. Reference Specification:

The following specifications shall be construed to be part of these specifications.

- 23 05 01 - Basic Mechanical Requirement
- 23 05 02 - Basic Mechanical Materials and Methods
- 23 05 10 - Equipment Installation
- 23 05 29 - Supports & Anchors

END OF SECTION 23 25 17

SPECIFICATIONS

PROJECT NO : 1890
PROJECT TITLE : SSGCL HEAD OFFICE BUILDING, KARACHI
DATED : 20TH APRIL, 2026

capacity and injection pressure ratings shall be appropriate for the application. Pump shall be complete with suction and injection fittings, polyethylene tubing and a pressure relief/anti-syphon valve.

Inhibitor and biocide feed pumps shall be similar to type as manufactured by LMI, USA.

- e) **Corporation Stop:** Bronze Corporation stops with CPVC nozzle assembly to allow chemical dispersion away from the pipe side wall to eliminate pipeline corrosion and to improve mixing of chemical in water and to allow easy nozzle withdrawal for servicing of injection check valve without shutdown of treated line.
- f) **Bleed-off Valve:** Solenoid operated cooling tower bleed-off valve shall be normally closed, 2-way, diaphragm, internally piloted valves with brass body and epoxy encapsulated UL listed coil and shall be suitable for outdoor use.

2. Chemicals:

- a) **General:** Water treatment chemicals, sufficient for two year's operation of the system at 70% average load, shall be supplied. Suitable professional test kits for testing water pre and post chemical dosing by operating personnel shall be supplied.

The quantity of chemicals to be supplied shall be based on the following operating hours:

- Office & commercial buildings-12 hours per day, 6 days per week.

The quantities of chemicals shall be based on actual analysis of water available for make-up and for this purpose; the contractor shall be responsible for obtaining and analysing sample of make-up water and must submit water analysis report along with detailed calculations for the verification of quantities of chemicals offered.

The following chemicals or approved equivalents, shall be supplied for the system:

- b) **Condenser Water System:** Non-chromate-based scale/corrosion inhibitor, similar to DREWGARD 308, to prevent scale and to inhibit corrosion.

Non-oxidising algaecide, similar to BIOSPERSE 250, to control microbiological growth.

Non-oxidising fungicide, similar to BIOSPERSE 280, to control microbiological growth.

Algaecide and fungicide shall have different chemical structures to prevent development of immunity by algae, slime etc.

Oxidising biocides will not be acceptable.

3. Water Analysis:

The Contractor shall be responsible for obtaining a water sample of the water to be used for makeup and having it chemically analysed to calculate the rate of addition of various chemicals.

4. Water Treatment Program:

This Contractor shall be responsible for providing a complete water treatment program for the water circuits. The program shall indicate the testing procedures, the rate of addition of chemicals, the concentration of chemicals to be maintained in the system, and type and frequency of service. All this information shall be submitted in an approved format bound in hard cover. 6 (Six) copies shall be submitted. Suitable professional test kits for testing water pre and post chemical dosing by operating personnel shall be supplied, with sufficient refills for two years of normal operation.

5. Installation:

The water treatment equipment shall be installed by the Contractor, complete in all respects. All necessary equipment and material required for a complete installation shall be

SPECIFICATIONS

PROJECT NO : 1890
PROJECT TITLE : SSGCL HEAD OFFICE BUILDING, KARACHI
DATED : 20TH APRIL, 2026

WATER TREATMENT SYSTEM FOR CONDENSER WATER CIRCUIT (LARGE SYSTEM)

1. Condenser Water System:

- a) **Flowmeter-Pulsar:** A Flowmeter-Pulsar shall continuously monitor the make-up water quantity to the cooling towers and shall feed inhibitor chemical to the make-up water line in direct proportion to the make-up water quantity, through a chemical metering pump.

The Flowmeter-Pulsar shall be magnetic drive turbine type meter with bronze body, straight reading register, centre sweep hand protected by high impact glass, permanently hermetically sealed between a glass dome and metal housing. The flowmeter shall have minimum 7 digit totalizer and shall be suitable for 0-55C service temperature and 10 bar maximum operating pressure. Flowmeter shall comply with or exceed all AWWA Class-1 turbine meter performance standards.

Flowmeter-Pulsar shall be similar to type RFP, as manufactured by LMI, USA.

- b) **Conductivity Controller:** A conductivity controller shall continuously monitor the system water conductivity. When the conductivity of the recirculating water reaches the pre-set maximum value, the controller shall automatically activate solenoid bleed-off valve to allow system water bleed-off.

The controller shall be menu-driven microprocessor based, with following features:

- i) Vacuum fluorescent alphanumeric digital display with 0-6000 micro Siemens control range.
- ii) LED type indicators for bleed, biocide-1 and biocide-2 outputs to indicate pump control status.
- iii) Isolated 4-20 mA recorder output signals for computer interface.
- iv) Lithium battery to provide non-volatile set point memory backup and to provide a 24-hour based real time clock.
- v) Two independent, alternating, programmable biocide feed functions, operating on a fourteen-day cycle with adjustable pre-set function and programmable lockout timer.
- vi) Flow switch with back flow check valve.
- vii) Temperature compensated, flat surface carbon electrode of PVC construction.

The controller shall be housed in a NEMA 4X fibreglass enclosure with hinged, lockable cover with gasketed, polycarbonate full view window and shall be similar to Model DC1000 as manufactured by LMI, USA.

- c) **Inhibitor Feed Pump:** Inhibitor feed pump shall be an instrument responsive electromagnetic positive displacement chemical metering pump, suitable to accept signals from the flow meter Pulsar and to automatically feed inhibitor chemical in proportion to the make-up water quantity. Pump shall be housed in a totally enclosed, corrosion proof glass fibre reinforced polypropylene housing. Pump output shall be adjustable by readily accessible dial knob for stroke length. Pump capacity and injection pressure ratings shall be appropriate for the application. Pump shall be complete with suction and injection fittings, polyethylene tubing and a pressure relief/anti-siphon valve.

- d) **Biocide Feed Pumps:** Biocide feed pumps shall be electromagnetic positive displacement diaphragm type chemical metering pumps. Pumps shall be housed in a totally enclosed, corrosion proof glass fibre reinforced polypropylene housing. Pump output shall be adjustable by readily accessible dial knob for stroke length. Pump



SPECIFICATIONS

PROJECT NO : 1890
PROJECT TITLE : SSGCL HEAD OFFICE BUILDING, KARACHI
DATED : 20TH APRIL, 2026

2. Vibration, with vibration analysis reports.
 3. Motor performance report.
 4. Impeller dia test.
 5. Pump performance, with no flow point & duty point plotted on pump curve
 6. Flow rate using ultra-sonic flow meter to cross-check flow.
- C. Impellers shall be trimmed for the proper flows after due approval by the Consultant.
- D. The Contractor shall be required to carry out tests, on forms to be supplied later by the Consultant, and obtain approval.

3.8 Cleaning:

- A. Refer Section 23 05 93.
- B. Remove labels after work is complete.
- C. Remove all splashed paint, cement splatter, protective paper, etc after work is complete, & deliver pumps in clean condition.

3.9 Protection of Finished Work:

- A. Protect all equipment & work from deterioration from any condition, till handing over.

END OF SECTION 23 21 30



SPECIFICATIONS

PROJECT NO : 1890
PROJECT TITLE : SSGCL HEAD OFFICE BUILDING, KARACHI
DATED : 20TH APRIL, 2026

D. Drainage of Free Water:

1. Make provision for free water to be caught, collected and drained away.

3.5 Foundation:

- A. Foundation for the pump shall be constructed of 1:2:4 concrete with nominal reinforcement, sized to provide an inertia block having a mass equal to 3 times the weight of the pump and motor. The foundation shall be isolated from the structure and plant room floor by using 40mm thick high density cork. Edges of the foundation shall be provided with 25×25×3mm angle iron frame work and painted with two coats of oil paint.
- B. Install dowel rods to connect concrete base to concrete floor. Unless otherwise indicated, install dowel rods on 18 inch (450mm) centers around full perimeter of concrete base.
- C. Coordinate sizes and locations of concrete bases with actual equipment provided. Cast epoxy-coated anchor-bolt inserts into bases.
- D. When shown on drawings, or with pumps mounted on upper floors, the pump's concrete foundation shall be supported on four suitably sized spring isolators.

3.6 Installation:

- A. The installation shall be carried out complete in all respects as per recommendations of the manufacturer & as specified herein.
- B. Install base-mounted pumps on cast-in-place concrete foundation.
- C. Pipe connections, electrical connections, drain connections, etc., shall be done by the Contractor complete in all respects.
- D. Pipe connections shall be installed through flexible connectors.
- E. Drain lines from pump base plate at drip pocket shall be installed.
- F. Pumps shall be properly leveled, grouted in and realigned before operation in accordance with the manufacturer's recommendations.

3.7 Commissioning & Testing:

- A. The pumps shall be commissioned and tested as per the manufacturer's recommendations, and shall be commissioned by a manufacturer's-authorized service representative. This Contractor shall be responsible to ensure that the intent of this clause is fully met.
- B. Commissioning shall as a minimum consist of the following:
 1. Complete installation and startup checks according to manufacturer's written instructions.
 2. Check piping connections for tightness.
 3. Clean strainers on suction piping.
 4. Perform the following start-up checks for each pump before starting:
 - a. Verify bearing lubrication.
 - b. Verify that pump is free to rotate by hand and that pump for handling hot liquid is free to rotate with pump hot and cold. If pump is bound or drags, do not operate until cause of trouble is determined and corrected.
 - c. Verify that pump is rotating in the correct direction.
 - d. Pump commissioning shall include reports on:
 1. Alignment of pumps, shafts & motor.



SPECIFICATIONS

PROJECT NO : 1890
PROJECT TITLE : SSGCL HEAD OFFICE BUILDING, KARACHI
DATED : 20TH APRIL, 2026

PART-3: EXECUTION

3.1 Examination:

- A. Before commencing work, verify that the pump is the correct one for the particular installation, that it is not damaged in any way, and that the space and surroundings are suitable for the installation and that adequate maintenance clearances are available.

3.2 Handling and Storage:

- A. Deliver pumps to site, completely identified in accordance with shop and certified drawings prepared for this work. Store in accordance with manufacturer's instructions, above ground, properly protected from the weather and construction activities.

3.3 Fabrication:

- A. All Pumps shall be fabricated in the manufacturer's works and delivered to site as a complete unit.

3.4 Installation:

A. Pre Installation Check:

1. Before beginning installation in any area, examine all parts of the adjoining work into which applicable work is to be placed. Should any conditions be found which will prevent the proper execution of the work, installation shall not proceed in that area until such conditions are corrected by the Contractor.
2. Ensure pumps are positioned to allow adequate space for maintenance and access.
3. Examine equipment foundations and anchor-bolt locations for compliance with requirements for installation tolerances and other conditions affecting performance of the Work.
4. Examine roughing-in for piping systems to verify actual locations of piping connections before pump installation.
5. Examine foundations and inertia bases for suitable conditions where pumps are to be installed.
6. Proceed with installation only after unsatisfactory conditions have been corrected.

B. Alignment:

1. Align pump and drive in accordance with manufacturer's recommendations. Engage a factory-authorized service representative to perform alignment service.
2. Comply with requirements in Hydronic Institute standards for alignment of pump and motor shaft. Add shims to the motor feet and bolt motor to base frame. Do not use grout between motor feet and base frame.
3. After alignment is correct, tighten foundation bolts evenly but not too firmly. Completely fill base-plate with non-shrink, nonmetallic grout while metal blocks and shims or wedges are in place. After grout has cured, fully tighten foundation bolts.

C. Pipeline Connections:

1. Support pumps independently from connecting pipe work to ensure no load is transmitted from pipe work to pump casing on pump suction and discharge.

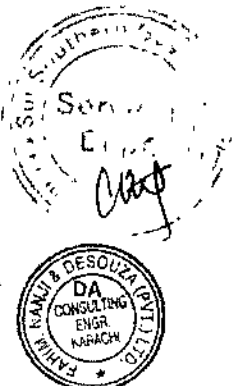

SPECIFICATIONS

PROJECT NO : 1890
PROJECT TITLE : SSGCL HEAD OFFICE BUILDING, KARACHI
DATED : 20TH APRIL, 2026

G. Mechanical Seals

1. Pumps shall be supplied with cartridge mechanical seals for ease of maintenance. The seals should be able to be replaced without removing the rotating assembly. The seals shall be located within the pump suction chamber with the pumped fluid providing lubrication and heat dissipation for the seal faces.
2. On positive suction conditions single cartridge seals will have seal faces positioned within pump suction passage to facilitate lubrication and cooling with no flush supply. On applications involving negative suction conditions flushing arrangement shall be provided to maintain positive pressures. This would normally be via re-circulation of the pumped fluid.

2.5 Vertical In-line Pumps- Special Requirements:

- A. Pump Design: The pump shall be of multi-stage vertical design suitable for vertical mode of operation, directly coupled to the motor. Arrangement shall allow access to the impeller for service and maintenance. Pump body shall incorporate in-line inlet and outlet connections.
- B. Casing: Pump body shall be of stainless steel AISI 304/DIN 14301.
- C. Bearings: Sealed-for-life type requiring no maintenance.
- D. Pump Seal: O-Ring shaft seals shall be used to produce a leak free pump, and failure of a pump seal shall not result in damage to the drive motor.

2.6 Close Coupled Centrifugal Pumps - Special Requirements:

- A. Pump Design: The pump shall be factory-assembled and tested, centrifugal, overhung impeller, close-coupled, in-line type, designed for installation with pump and motor shafts mounted horizontally or vertically.
- B. Pump Construction:
 1. Casing: Radially split, cast iron, with threaded gage tapings at inlet and outlet, replaceable bronze wear rings, and threaded/flanged connections.
 2. Impeller: ASTM B 584, cast bronze; statically and dynamically balanced, keyed to shaft, and secured with a locking cap screw.
 3. Pump Shaft: Stainless steel.
 4. Seal: Mechanical seal consisting of carbon rotating ring against a ceramic seat held by a stainless-steel spring, and [Buna-N] [EPT] bellows and gasket. Include water slinger on shaft between motor and seal.
 5. Pump Bearings: Permanently lubricated ball bearings.

2.7 Direct Drive, In-Line Centrifugal Pumps - Special Requirements:

- A. Pump Design: The pump shall be of single stage design suitable for horizontal or vertical mode of operation, with pump body incorporating inlet and outlet connections in line, to allow pump to be mounted in pipe work, directly coupled to the motor. Arrangement shall allow access to the impeller for service and maintenance.
- B. Casing: Non-Corrosive alloy.
- C. Bearings: Sealed-for-life type requiring no maintenance.
- D. Pump Seal Failure: Close coupled pumps shall be arranged such that the failure of a pump seal shall not result in damage to the drive motor.
- E. Twin Headed Pumps: Where twin headed pumps are specified, a spare blanking plate and two spare gasket sets shall be provided per pump set.



SPECIFICATIONS

PROJECT NO : 1890
PROJECT TITLE : SSGCL HEAD OFFICE BUILDING, KARACHI
DATED : 20TH APRIL, 2026

2.3 Separately Coupled, Base Mounted, End-Suction Centrifugal Pumps-Special Requirements:

- A. Pump Design: The pump shall be of single stage, vertically split casing design suitable for horizontal mode of operation, with end suction and top discharge.
- B. Casing: Casing shall be vertical split with centerline discharge, foot-supported.
- C. Casing Joint Gasket: An O-Ring shall be provided at the casing joint to prevent leakage.
- D. Bearing Frame: shall be rigid, one piece cast iron construction. Frame shall be provided with catch basin reservoir with tapped drain hole to collect and pipe away stuffing box leakage.
- E. Bearings: shall be ball type on both ends of the frame. The bearings shall have a L10 life of 50,000 hours. Both bearings shall be locked in place and be sized to provide long life under thrust loads encountered. Both bearings shall be enclosed by replaceable box. Ball bearings shall be grease lubricated with provisions for the addition & relief of grease.

2.4 Separately Coupled, Base Mounted, Horizontal Split Case Centrifugal Pumps - Special Requirements:

- A. Pump Design: The pump shall be of single/multi-stage horizontally split casing design. The impeller/shaft assembly shall be supported between bearings. Impellers shall be of the double entry shrouded type. Casing shall be of double volute design to reduce radial loading.
- B. Pump Casing
 1. Suction and delivery branches shall be incorporated in the bottom half casing and include NPT tapings for pressure gauges. Austenitic stainless steel drain plugs shall be provided at the lowest point of the casing and air release valves (of bronze or stainless steel construction) at the highest point.
 2. The pump removable half casing shall have eyebolts fitted for ease of lifting during disassembly. The removable half casing shall also have dowels for alignment and jacking screws.
- C. Pump casing split flange bolting shall be high tensile steel.
- D. Thrust/Journal Bearing: The generated axial and radial thrusts shall be taken by appropriate rolling element deep groove ball or paired angular contact bearing. The pump journal bearing shall be an appropriate deep grooved ball bearing, be grease lubricated.
- E. Rolling Element Bearings
 1. Rolling element bearings shall be rated to give a minimum L10 life of 50,000 hours at the rated operating load without replacement.
 2. All deep groove ball bearings shall be sealed for life using long life grease. All grease shall exceed calculated L 10 bearing life.
 3. On high-energy pumps requiring paired angular contact thrust bearings bearing arrangements involving grease replenishment are acceptable.
- F. Bearing Housings:
 1. The bearing housings shall be mounted for ease of realignment. The thrust bearing shall be locked and located axially on both the pump shaft and bearing housing.
 2. The journal bearing arrangement shall be such that the bearing position is free to allow axial movement within the bearing housing.



SPECIFICATIONS

PROJECT NO : 1890
PROJECT TITLE : SSGCL HEAD OFFICE BUILDING, KARACHI
DATED : 20TH APRIL, 2026

- I. Baseplate: shall be of heavy duty, fabricated steel or cast iron, designed to resist torsional movement and sufficiently rigid to support the pump and the driving motor and provided with tap hole to pipe away leakage and condensation.
- J. Pump Casing: The casing shall be of high grade cast iron to ASTM A48 class 40 (BS1452 Grade 250) or Ductile Iron to ASTM A536 Grade 60-40-18 (BS 2789 Gr. 400/18). Suction and delivery branches shall be incorporated in the casing and include NPT tapings for pressure gauges. Austenitic stainless steel drain plugs shall be provided at the lowest point of the casing and air release valves of bronze or stainless steel construction.
- K. Casing Wearing Rings: Easily replaceable casing wearing rings of suitable material for service shall be provided in front and rear of impeller. Casing wear rings shall be locked to prevent rotation by dowel or similar approved method. Ease of replacement shall be a major design criterion. Casing wear rings shall be incorporated on all rotating/stationary interfaces.
- L. Impeller: shall be the single/multi section enclosed type, of ASTM B584 cast bronze. Impeller shall be statically and hydraulically balanced in accordance with ISO 1940 G6.3. Impeller shall be keyed & locked to the shaft with a hexagonal head impeller nut and shall be easily removable without the use of special tools.
- M. Mechanical Seal: All pumps shall be fitted with mechanical seals of the self-adjusting type, suitable for the particular operating application, temperature and pressure. The pump construction shall allow for replacement of bearings/mechanical seals without dismantling pipe work or the motor. The mechanical seal shall be hydraulically balanced with the springs protected from the pumped fluid. The stationary seat shall be Silicon Carbide and the rotating face Carbon Graphite. All seal metallic components shall be Stainless Steel ASTM A351 Grade CF8M (BS EN 10213-4 No 1.4408) or better. The pump manufacturer shall specify the type, size and material of the mechanical seal he intends to supply.
- N. Pump Shaft: The shaft material shall be Stainless Steel to ASTM S43000 or better. Shaft critical speed should exceed the maximum operating speed by at least 50%. Shaft Deflections at mechanical seal faces should not exceed 0.05mm.
- O. Couplings: Flexible spacer couplings shall be provided as standard on horizontal arrangements to permit the removal of mechanical seals and bearings without removing the pump casing or motor.
- P. Coupling Guard: shall be metallic with guards fixed to either the pump set bed-plate; pump or motor whichever is appropriate, to ensure that couplings are totally enclosed. Openings at gland locations shall be guarded using perforated plate to allow viewing of leakage in the event of seal failure.
- Q. Bearings: Shall have a life L10 of 50,000 hours.
- R. Matching Flanges: Provide flanged pumps with matching flanges to relevant standards.
- S. Paint/Coating: Casing shall have approved listed "pump coating", suitable for the environmental conditions.
- T. Pump Connections: Pump connections shall be screwed for sizes up to 50mm and flanged on sizes 65mm and above.
- U. Rating Plates/Markings: Rating plates shall be fitted to all pumps, manufactured and fixed by corrosion resistant materials and shall include full details of the pump including type, serial number, duty point flow, head, speed, suction pressure, discharge pressure, year of manufacture, and min/max fluid temp.
- V. Spares: Provide spares as indicated under EQUIPMENT DATA SHEET.

SPECIFICATIONS

PROJECT NO : 1890
PROJECT TITLE : SSGCL HEAD OFFICE BUILDING, KARACHI
DATED : 20TH APRIL, 2026

1.10 Inspection & Testing:

- A. Each pump shall be statically hydraulically tested at the works to a pressure at least 50% greater than the maximum working pressure that it will incur. The test pressure shall be maintained for at least 30 minutes. During the test the pump shall show no signs of leakage or failure of any components.
- B. If required the pumps shall be tested in accordance with procedures described in BS EN ISO standards at the manufacturers premises to verify that the pump achieves the duty point values as specified.
- C. All pumps with a flow duty in excess of 150 litres/sec (2400 USgpm) shall be performance tested at manufacturer's works in accordance with BS EN ISO standards to verify that the pump achieves the duty point values as specified. Test data shall be submitted.
- D. If indicated in the BOQ, allow for inspection and witnessing by a Client and Consultant's representative. Allow for all Client and Consultant's representatives' travel, accommodation and subsistence expenses associated with the inspection/ witnessing.

PART-2: PRODUCTS

2.1 Approved Manufacturer or Product:

- A. Refer section 23 90 10- List of Approved Manufacturers.

2.2 Centrifugal Pumps- Common Requirements:

- A. Standards: All individual components of the pumps shall comply with the relevant standards and appropriate sections of this specification.
- B. Pressure Rating: Pump casing shall be designed to withstand the discharge pressure specified in the EQUIPMENT DATA SHEET plus the static head on the system, plus 50% of the total head, but not less than 125 psi (8.5 bars).
- C. Pump Selection: Select pump at or near most efficient part of performance curve for duty required. The pump curves shall be superimposed on system curves and operating conditions verified prior to ordering the pump.
- D. System Resistances: The pump heads indicated in the EQUIPMENT DATA SHEET are to be considered approximate and the Contractor shall calculate the actual resistance based on the coordinated installation drawings and on actual equipment selected.
- E. NPSH: The Contractor shall ensure that the pumps selected meet the actual NPSH available on site for the application.
- F. Pump Speed: The pump RPM shall be as specified in the EQUIPMENT DATA SHEET. If this is not indicated, other than multistage pumps and pumps that have a volumetric duty of less than 47 litres/s (750 USgpm), pump impeller speeds shall be less than 1500rpm. Where speeds do exceed 1500 rpm the pump shall utilize special quiet running bearings.
- G. Motor Size: Motors shall be selected with a Service Factor of 1.2 or as indicated on the EQUIPMENT DATA SHEET and shall also be sized to ensure non-overloading of motor for single pump operation in a parallel pumping configuration.
- H. Motor Specifications: Motors shall conform to specifications given under "Motors" (Section 23 05 13). Motors shall be mounted with pump on base-plate in manufacturer's plant and shipped as one unit.

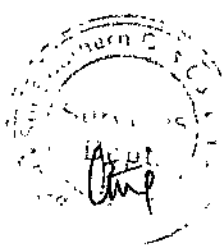

SPECIFICATIONS

PROJECT NO : 1890
PROJECT TITLE : SSGCL HEAD OFFICE BUILDING, KARACHI
DATED : 20TH APRIL, 2026

8. BS 5316-1, 1976; ISO 2548:1973-Specification for acceptance tests for centrifugal, mixed flow and axial pumps. Class C tests.
9. BS 5316-2, 1977; ISO 3555:1977-Specification for acceptance tests for centrifugal, mixed flow and axial pumps. Class B tests.
10. BS EN ISO 5198 Centrifugal, mixed flow and axial pumps. Code for hydraulic performance tests. Precision class.
11. BS EN ISO 9906:2012- Roto-dynamic pumps. Hydraulic performance acceptance tests. Grades 1, 2 and 3.

1.4 Submittals For Review:

A. Product Data: For each type of pump.

1. Include rated capacities, furnished specialties, and accessories for each pump.
2. Submit pump operating curves indicating pump head/flow; power absorbed/flow; overall efficiency/flow; pump efficiency; & NPSH/flow, with system operating conditions indicated.
3. Certified pump sound-power ratings.
4. Motor ratings and electrical characteristics, plus motor and electrical accessories.
5. Submit certification documents to substantiate certification specified:
6. Submit copies of test reports required to be performed on the proposed products.
7. Submit Manufacturer's Warranty in conformance to specifications given elsewhere.

1.5 Quality Assurance:

- A. Pumps shall be designed and constructed to operate satisfactorily for the specified application, and shall be the product of a manufacturer regularly engaged in the production and marketing of these pumps.
- B. Pumps shall conform to relevant BS, EN, ISO and relevant industry standard codes.
- C. All pumps shall be fully tested at works; with performance characteristics guaranteed in accordance with BS5316 Part-1&2 and BS EN ISO 5198 as appropriate.

1.6 Qualifications:

- A. Equipment shall meet or exceed the certification requirements specified.

1.7 Mock-Up:

- A. No requirements.

1.8 Environmental Requirements:

- A. Pumps shall be suitable for the environment in which they are sited and for the liquid that flows through it.
- B. The external environment shall be considered to be hot (up to 46°C), humid (up to 32°C saturated and moisture contents up to 0.030 kg/kg), dusty (up to 70 mg/m³). Installations close to shoreline cities shall also consider a saline environment.

1.9 Warranty:

- A. Submit Manufacturer's Warranty in accordance with contract requirements specified elsewhere.

SPECIFICATIONS

PROJECT NO : 1890
PROJECT TITLE : SSGCL HEAD OFFICE BUILDING, KARACHI
DATED : 20TH APRIL, 2026

CENTRIFUGAL PUMPS

PART-1: GENERAL

1.1 Scope of Work:

- A. This section describes the technical and workmanship requirements for the following pumps:
1. Separately coupled, base mounted, end-suction centrifugal pumps.
 2. Separately coupled, base mounted, horizontal split case centrifugal pumps.
 3. Vertical in-line multi-stage centrifugal pumps.
 4. Close-coupled, in-line centrifugal pumps.
 5. Direct Drive, In-Line Centrifugal Pumps.
- B. The Contractor shall furnish and install Centrifugal Pumps of configuration & capacities as scheduled in EQUIPMENT DATA SHEET, and specified hereunder.
- C. Furnish all labor, materials, plant, equipment and appliances and perform all necessary operations required to execute the work of this Section.

1.2 Related Sections:

- A. Drawings and General & Special Conditions of Contract apply to this Section.
- B. The Contractor shall become familiar with other Sections of the Specifications affecting work of this trade, and shall comply with them in carrying out work under this section.
- C. In particular the following should be referred:
1. 23 05 01- Basic Mechanical Requirements
 2. 23 05 02- Basic Mechanical Materials & Methods
 3. 23 05 10- Equipment Installation
 4. 23 05 13- Electric Motors
 5. 23 05 48- Vibration Isolation & Control
 6. 23 05 93- Cleaning, Adjusting, Testing and Commissioning
 7. 23 05 94- Test Run

1.3 Standards:

- A. The minimum standards for products specified in this section shall be those standards referred to or relevant BSI standards.
1. BS EN ISO 5199:2002 - Technical specifications for centrifugal pump.
 2. BS 5257:1975-Specification for horizontal end-suction centrifugal pumps (16bar).
 3. BS EN ISO 5199:2002 - Technical specifications for centrifugal pumps - Class II.
 4. EN ISO 9905:1994 - Technical specifications for centrifugal pumps - Class I.
 5. EN ISO 9908:1993 - Technical specifications for centrifugal pumps - Class III.
 6. BS EN ISO 14847:1999-Rotary positive displacement pumps - Technical requirements.
 7. BS EN ISO 21049:2004 - Pumps - Shaft sealing systems for centrifugal & rotary pumps. *



SPECIFICATIONS

PROJECT NO : 1890
PROJECT TITLE : SSGCL HEAD OFFICE BUILDING, KARACHI
DATED : 20TH APRIL, 2026

in each line immediately preceding the connection to each piece of equipment such as coils, pumps, control valves & other similar items.

11. Pipe Supports:

Refer Section 23 05 29, SUPPORTS & ANCHORS.

12. Pressure Testing:

Water and steam piping shall be hydrostatically tested at a pressure equal to 150% of the maximum operating pressure, but not less than 150psi (10 bars), for a period of time sufficient to inspect every joint in the system but in no case less than two hours. No loss of pressure will be allowed. Leaks found during tests shall be repaired by rewelding or replacing pipe or fittings. Caulking of joints will not be permitted. Concealed piping shall be tested in place before concealing. Tests shall be conducted in the presence of the Engineer or the Engineer's representative who shall be given 10 days notice before any test is to be conducted. All material, equipment or instruments required for tests shall be provided by the Contractor.

13. Reference Specification:

The following specifications shall be construed to be part of these specifications.

- 23 05 01 - Basic Mechanical Requirement
- 23 05 02 - Basic Mechanical Materials and Methods
- 23 05 10 - Equipment Installation
- 23 05 11 - Pipe Welding
- 23 05 23 - Valves & Strainers
- 23 05 29 - Supports & Anchors
- 23 05 48 - Vibration Isolation & Control
- 23 05 50 - Painting & Coating
- 23 05 53 - Mechanical Identification

END OF SECTION 23.21.13

SPECIFICATIONS

PROJECT NO : 1890
PROJECT TITLE : SSGCL HEAD OFFICE BUILDING, KARACHI
DATED : 20TH APRIL, 2026

- c) The instrument head shall comprise a switch unit and terminal block enclosed in a cast aluminium alloy housing with bolted cover and neoprene gasket.
- d) The mounting unit shall be of brass, and be screwed 25mm for insertion in the pipe work.
- e) Flow switches shall be suitable for the working pressures and temperatures encountered.

10. Installation:

- a) **General:** Pipes shall be cut accurately to measurements established at the job site and worked into place without springing or forcing, properly clearing all windows, doors and other openings. Excessive cutting or other weakening of the building structure to facilitate piping installation will not be permitted without written approval. Layout drawings required under the title of "Approval of Material & Equipment" shall show locations of all supports, the load imposed on each fastening or anchor, typical details for special anchorage, for suspended piping, valves, tank, pumps, converters, and other mechanical equipment. Where supports are required between structural framing members, suitable intermediate metal framing shall be provided and detailed. Pipe shall have burrs removed by reaming and shall be installed to permit free expansion and contraction without damage to joints and hangers. Changes in direction shall be made with fittings, except that bending of pipe 100mm and smaller will be permitted, provided a pipe bender is used and wide-sweep bends are formed. The centre line radius of bends shall not be less than 6 diameters of the pipe. Bent pipe showing kinks, wrinkles, flattening or other malformations will not be accepted. All piping shall be installed with sufficient pitch to ensure adequate drainage and venting. Piping connections to equipment shall be provided with unions or flanges. Open ends of pipelines or equipment shall be properly capped or plugged during installation to keep dirt and other foreign matters out of the system.
- b) **Screwed joints:** shall be made with tapered threads properly cut. Joints shall be made tight with a stiff mixture of lethargy and glycerine, or polytetrafluoroethylene (PTFE) tape, or approved thread joint compound applied to the male thread only. Not more than three threads shall show after the joint is made up. For steam piping do not use PTFE tape.
- c) **Welded joints:** shall be fusion welded by metal arc welding method unless otherwise required. Changes in direction of piping shall be made with welding fittings only. Mitering or notching pipe to form elbows & tees or other similar construction will not be permitted. Branch connections shall be made with welding tees or forged welding tees or forged welding outlets.

Field and shop bevels shall be in accordance with the recognised standards and shall be done mechanically by means of flame cutting. Where bevelling is done by flame cutting, surfaces shall be clean of scale and oxidation prior to welding.

Before welding, the component parts to be welded shall be aligned so that no strain is placed on the weld when finally positioned. Height shall be so aligned that no part of the pipe wall is offset by more than 20% of the wall thickness. Flanges and branches shall be set true. This alignment shall be preserved during the welding operation.

Removing and replacing defective welds shall be at no additional cost to the Owner. Repairing of defective welds by adding new material over the defects or by peeling will not be permitted. Electrodes shall be stored in a dry heated area and shall be kept free of moisture or dampness during fabrication operations. Electrodes that have lost part of their coating shall be discarded.

- d) **Flanges and Unions:** shall be faced true. Flanges shall be provided with 1.6mm gasket of material suitable for specified usage, but shall not use asbestos, and made square and tight. Except where copper tubing is used, union or flange joints shall be provided

SPECIFICATIONS

PROJECT NO : 1890
PROJECT TITLE : SSGCL HEAD OFFICE BUILDING, KARACHI
DATED : 20TH APRIL, 2026

appropriate U-bend, with the open end of each tee plugged tight. All drains connected to pressurised circuit shall be provided with Ø 20mm gate valves.

6. Automatic Air Vents for Liquid Systems:

Automatic air vents shall be suitable for liquid systems. Body and cover shall be of malleable iron. Float & Valve seat shall be of stainless steel. Valve head shall be of Vitone (Synthetic Rubber). Connections shall be 13mm or 20mm as specified, screwed BSP. Vents shall be suitable for service upto 125 SWP (8.5bars) & 250°F (120°C) service.

Vents shall be similar to model AE 550 manufactured by SPIRAX-SARCO.

Air vents shall be provided at all high points, on all water coils, and where shown on the drawings to ensure adequate venting of the piping system. A ball valve shall be provided to isolate the vent. The vent outlet shall be piped to a nearby convenient drain using suitable diameter flexible transparent PVC tubing.

7. Expansion Joints:

a) Where indicated on the drawings, expansion joints shall be provided. Expansion joints shall also provided in all lines subject to temperature changes where indicated or required to relieve strain developed in lines due to temperature increase or decrease.

Pipe alignment guides shall be installed as recommended by the joint manufacturer but in any case not more than 1.5m on each side of expansion joint, except in lines 100mm or smaller they may not be over 600mm on each side of joint.

b) Anchors shall be provided wherever necessary or indicated to localise expansion or to prevent undue strain on piping. Anchors shall consist of heavy steel collars with lugs and bolts for clamping and attaching anchor braces, unless otherwise indicated. Anchor braces shall be installed in the most effective manner to secure the desired results, using turnbuckles wherever required. Anchors, supports or stays shall be attached in places where such supports will not injure the construction during installation or damage the structure by the weight or expansion of the pipeline. Detailed drawings of pipe anchors shall be submitted for approval before installation.

8. Flexible Connectors:

Flexible connectors shall be constructed of rubber, tetrafluoroethylene resin, or corrosion resisting steel, bronze, monel or galvanised steel. The material used and the configuration shall be suitable for pressure, vacuum, temperature and circulation medium. The flexible sections may have threaded, welding, soldering, flanged or socket ends and shall be suitable for service intended. The flexible section may be reinforced with metal retaining rings, with built in reinforcement and restriction bolts or with wire braid cover suitable for the service intended. Flanged assemblies shall be equipped with limit bolts to restrict maximum travel within limits standard with the manufacturer. Unless otherwise shown on the drawings, the length of the flexible connector shall be as recommended by the manufacturer for the service intended. Internal sleeves or liners shall be provided when recommended by the manufacturer suitable for the circulating medium. Covers to protect the bellows will be provided where necessary or directed. Flexible connectors shall be designed for 125Psi (8.5 bars) service, and 250°F (120°C).

Flexible pipe connectors shall be installed on piping connected to equipment where indicated on the drawings. Installation shall be in accordance with manufacturer's recommendations.

9. Flow Switches:

- a) Flow switches shall be as per manufacturer's standard, comprising a water or air-immersed vane, deflection of which activates an adjustable electrical switch.
- b) Vane and spindle assembly shall be fabricated from stainless steel, the joint between vane and spindle being argon arc welded.

SPECIFICATIONS

PROJECT NO : 1890
PROJECT TITLE : SSGCL HEAD OFFICE BUILDING, KARACHI
DATED : 20TH APRIL, 2026

HYDRONIC PIPING & SPECIALITIES

1. Piping Material:

- a) **Seamless Black Steel Piping:** Seamless black-steel piping, Schedule 40 conforming to ASTM A53.
- b) **Mild Steel Pipe:** conforming to BS1387 (medium series), screwed upto 50mm (2 inch) & welded above \varnothing 50mm (2 inch).
- c) **Mild Steel Pipe:** conforming to ASTM A53, Schedule-40, screwed upto 50mm (2 inch).
- d) **Galvanised Iron Pipe:** G.I. Pipe shall conform to BS1387 of 1957 (Medium Series), welded type. Fittings shall be of galvanised malleable iron. Fittings upto 100mm shall be screwed.
- e) **Copper Tubing:** shall be type 'K' hard seamless, conforming to BS1172 and manufactured to BS2871; Pt.1, Table X. Fittings shall be of wrought copper conforming to BS864, Pt.2.
- f) **UPVC Piping:** Pressure piping conforming to ASTM D1785 or BS3505 of 1968. Jointing shall be solvent welded. Fittings shall be injection moulded of high density & shall be imported.

2. Application:

- a) **Chilled/Hot & Condenser Water Piping** shall be of material as specified under PIPING SCHEDULE in EQUIPMENT DATA SHEET (Section 2).
- b) **Natural Gas Piping** shall be of material as specified under PIPING SCHEDULE in EQUIPMENT DATA SHEET (Section 2).
- c) **Fan Coil Unit connections** shall be of material as specified under PIPING SCHEDULE in EQUIPMENT DATA SHEET (Section 2).
- d) **Make-up Water & Drain Lines** shall be of material as specified under PIPING SCHEDULE in EQUIPMENT DATA SHEET (Section 2).

3. Fittings & Flanges:

- a) Fittings shall be forged, compatible to the pipe. Welded fittings shall be butt-welding type. Galvanised piping shall be provided with galvanised fittings with threads. All fittings shall be rated for minimum 10 bars SWP.
- b) Flanges shall be slip-on type & shall conform to ANSI B16.5. Galvanised piping shall be provided with galvanised threaded flanges. All flanges shall be rated for minimum 10 bars SWP.

4. Valves & Strainers:

Refer Section 23 05 23, VALVES & STRAINERS.

5. Drains:

Shall be provided at all low points to ensure complete drainage of the piping. Drains from steam lines shall be provided with steam traps. All air handling units and fan coil units shall be provided with condensate drains, which shall be installed with a gradient of 1% (one percent) in the direction of the flow. Drains indicated to be connected to sanitary sewer system shall be connected by means of an indirect waste. Clean-outs and water seals shall be provided for cleaning. Water seals shall be provided in the condensate drains of all units. The depth of the seal shall be at least equal to 1.5 times the total static pressure rating of the unit to which the seal is connected. Water seals shall be constructed of two tees and an

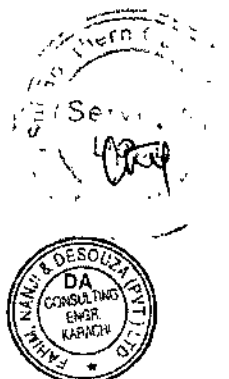

SPECIFICATIONS

PROJECT NO : 1890
PROJECT TITLE : SSGCL HEAD OFFICE BUILDING, KARACHI
DATED : 20TH APRIL, 2026

The SDC shall provide connectivity to the currently marketed FMCS solutions offered by the manufacturer. The SDC shall be interoperable these FMCS offerings for scheduling, global data sharing, energy demand limiting, alarming, optimised start/stop, and systems integrations for all other data within the entire FMCS. In addition, the SDC shall provide connectivity to existing DDC controllers currently marketed by the manufacturer.

The SDC shall be compliant with the current and previously marketed HMIs of the manufacturer, and shall be capable of full bi-directional communications through the LAN, with previously manufactured SDC controllers sold for the last ten years by the manufacturer.

9. Wiring:

All wiring used for control circuitry shall be single strand, colour coded multi-core cable, as recommended by the control manufacturer. Installation specifications as given under "Electrical Work" shall be generally followed for all electrical work for the control system.

10. Installation:

All control components shall be installed in a neat and workmanlike manner and as per strict recommendations of the control manufacturer. Prior to installation, complete wiring diagrams shall be submitted by this Contractor identifying control components, their location, interconnecting wires, etc., including installation details and the Engineer's approval obtained. The controls equipment and components shall be installed under the direct supervision of the manufacturer's representative for which suitable arrangements shall be made by this Contractor.

11. Commissioning and Testing:

After the completion of installation, testing of the control system by the control manufacturer's representative shall be arranged by this Contractor as required to ascertain specified operations. All control components shall be adjusted to the proper control point setting. A schedule of all settings shall be prepared by this Contractor. Before the air conditioning installation is handed over, the Contractor shall deliver to the Engineer's a statement from the controls manufacturer or his authorised agent certifying that the automatic control system has been inspected and found to be properly installed and functioning satisfactorily.

12. Project Records:

Complete project records describing individual component operation, system operation, and specific application, shall be provided at job completion. Project records shall provide complete and detailed step by step operating instructions.

As-built installation drawings shall be provided, indicating the mechanical & electrical equipment connected to the environmental control system.

During job acceptance, the contractor shall provide complete training of building personnel, utilising the project records outlined.

13. Control Sequence:

Shall be specified under sequence of operation of control system refer EQUIPMENT DATA SHEET (Section 2).

END OF SECTION 23 09 20



SPECIFICATIONS

PROJECT NO : 1890
PROJECT TITLE : SSGCL HEAD OFFICE BUILDING, KARACHI
DATED : 20TH APRIL, 2026

built-in interface. Systems that require the SDC to be removed from service while DDC control sequences are modified shall not be acceptable.

SDC controllers shall utilize true floating-point arithmetic capabilities. To accommodate tantalization of large totalised values, SDCs with reporting capability shall support the calculation, accumulation and display of values within the range of ± 10 to the 10th power. The SDC shall employ a multi-tasking, multi-user operating system.

All programming defining the functions to be performed by the SDC, including but not limited to application programs and point database within each SDC shall be protected from loss due to power failure for a minimum of six months. Systems not providing non-volatile memory shall provide a system rechargeable battery backup system sufficient to provide protection for the specified 6 month period.

SDC controllers shall be equipped with a minimum of two operator service ports for the connection of serial devices such as the GP, HMI, modems, printers, etc. Connection of a service device, to a service port, shall not cause the SDC controller to lose communications with its peers or other networked device controllers. The SDC shall be able to route alarms, trends, and reports to any serial device connected to the network. This shall also include auto-dialling to remote locations. The SDC shall be capable of dialling out to a minimum of ten remote locations for the annunciation of alarms. Alarms shall include the time, date, and alarm condition, in addition to a user-defined detailed message detailing the condition.

The SDC shall provide alarming, point trending and energy report generation capabilities. Alarming points shall be uniquely definable, with multiple alarms assignable to a single point. Such alarms shall be provided with a unique 80 character message. Systems utilizing an alarm messages library shall describe the size of the library and verify how all alarming within the SDC will be guaranteed unique 80 character messages.

The quantities of trended point values shall be limited only by total controller memory space. If necessary, a SDC may be dedicated fully to a trending task, allowing all controller memory to be available for the trend storage. Each unique trend report shall contain a minimum of 4 different points and a minimum of 128 samples per point. Trending frequency for each report shall be operator definable from a sample once a second to a sample once every 24 hours. Trend reports shall be internally formatted by the SDC and shall be reportable directly to a serial printer, a VT-100 display terminal, a CCS, CHS or any other device capable of receiving a formatted ASCII data file.

The energy reports shall not be limited in quantities only by available memory within the GDC. Each energy report shall be fully formatted and reportable to a serial printer, a VT-100 display terminal, a CCS, a CHS or any other device capable of receiving a formatted ASCII data file. As a minimum, each energy report shall provide a daily report and a monthly report with summary information such as outside air temperature, outside air humidity, total energy consumed and degree-day calculations.

The SDC controller shall provide a built-in operator interface, which consists of an alphanumeric LCD display of 4 lines x 20 characters, and a multi-function keyboard. Devices without such built-in displays shall provide a permanently connected HMI as described elsewhere in this specification, one per SDC.

The SDC shall provide for logical grouping of network variables and allow for viewing and editing of system parameters. Logical grouping menus shall allow for detailed descriptions of system variables of a minimum of 20 characters.

The SDC shall communicate via the FMCS Network Interfaces to the enterprise LAN, whether dedicated or common. The SDC shall provide communications connectivity to the LonWorks bus and shall support any LONMARK/LonWorks compliant devices.

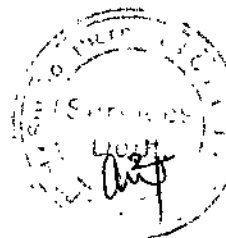

SPECIFICATIONS

PROJECT NO : 1890
PROJECT TITLE : SSGCL HEAD OFFICE BUILDING, KARACHI
DATED : 20TH APRIL, 2026

5. Actuators:

Actuators shall be electro-thermal or electro-hydraulic type and shall have a minimum number of moving parts.

Actuators shall have remote override & minimum positioning capability.

- a) Damper Actuators shall be provided with all necessary mounting brackets, rods etc.
- b) Valve Actuators shall mount directly on the control valve without requiring any adjustment of the actuator stroke. Actuators shall have manual operation capability.

6. Control Valves:

Control valves 50mm and below shall be threaded connection. Valves 65mm and above shall be flanged. Valves shall be supplied with a minimum body pressure rating of 10 bars.

Threaded valves shall be of gunmetal (bronze) and flanged valves of cast iron (up to 25 bar) or cast steel (40 bar).

All valves whether two ports or three ports shall be closed when the spindle is in the up position. Two port valves shall have an equal percentage control characteristic. Three port valves shall have an equal percentage characteristic on the through port and linear characteristic on the bypass port.

Valves shall be sized to have a full flow pressure drop equal to or greater than the pressure drop through the water coil being controlled, but not more than 40 kPa.

Two port valves shall have a close off capability equal to or greater than the maximum possible system differential pressure (As determined by the pump head or the system differential pressure bypass control setting).

Three port valves shall have closed off capability equal to or greater than the combined full flow pressure drops of the coil plus the valves itself.

Two port control valves for differential pressure bypass control applications shall be sized to handle at least the full flow through one chiller at the desired pressure setting. The valve shall be capable of closing off against this pressure and of operation at this pressure for long periods without internal wear or noise.

7. Water Flow Switch:

Water flow switch shall be paddle type to sense the flow in pipe lines. The paddle shall be available in different sizes to suit the pipe size. Flow switch shall be rain tight & with suitable enclosure to use in high humidity atmospheres and shall be suitable to work with 10 bars liquid pressure and 250°F (105°C) temperature. Electrical switch rating shall be minimum 5 Amps at 230 volts.

8. Stand-alone Digital Controllers:

Stand-alone Digital Controllers (SDC) shall be electronic microprocessor type, consisting of an electronic module with a case and a plug in connection terminal block. The SDC shall have a terminal connection to connect SDC on a 2 wire communication bus to form a centrally controlled building automation system.

The SDC shall be suitable for mounting on panel doors, inside panels or in rack assemblies. The terminal block shall carry markings to clearly identify the function of all wires connected to it.

The SDC shall offer a choice of proportional (P), proportional plus integral plus derivative (PID) control action, which shall be field selectable.

The SDC shall permit the simultaneous operation of all control, communication facilities management and operator interface software, as programmed by the Contractor or User. Modification of the on-board SDC controller database shall be performed on-line using the

SPECIFICATIONS

PROJECT NO : 1890
PROJECT TITLE : SSGCL HEAD OFFICE BUILDING, KARACHI
DATED : 20TH APRIL, 2026

AUTOMATIC CONTROL SYSTEM

1. General Requirements:

- a) Furnish and install an automatic control system for the monitoring and control of the mechanical equipment specified. The system shall be electronic type, with connections to the auxiliary equipment, sensors, controlled devices and all other equipment required for a fully operational control system.
- b) It is the intent of these specifications to describe the performance requirements of an automatic electronic control system. Therefore, these specifications describe the operational functions of the system and present guideline requirements for equipment to accomplish these functions. Any deviations from the desired performance specified, shall be detailed in writing, clearly indicating what it will do and what it will not do, and submitted with the bid.
- c) The environmental control manufacturer shall have at least a five year successful history in manufacturing electronic control systems for HVAC equipment.
- d) The control manufacturer's local representative shall have successfully commissioned 5 equal or larger size jobs. A reference list to this effect shall be submitted. The local representative for Pakistan shall also have at least one factory trained engineer on its payroll. The certificates for their successful completion of training shall be submitted.
- e) Bid submitted must be accompanied with a technical proposal describing equipment specifications, capabilities, future expansion, and operation. A schematic drawing of the control system must be submitted showing all components necessary to perform the function intended. It will be the contractor's responsibility to include all items required for a complete functional system.

2. Temperature Sensors:

- a) Temperature sensors shall be of the Balco resistance element type, 1000 ohms $\pm 0.1\%$ at 21°C & changes 2.2 ohms per 0.5°C at 21°C . Sensors shall be factory calibrated & shall not require compensation for cable lengths, etc.
- b) Room sensors shall have NEMA Type-1 location suitability & sensing range $4-60^{\circ}\text{C}$.
- c) Duct sensors shall have an insertion element of at least 200mm. Sensors shall have separate mounting flange to permit sensor removal from its enclosure. Sensing range shall be -40 to $+121^{\circ}\text{C}$. Where specified, averaging sensors shall be provided with an element length of 1.5m or 6m.
- d) Immersion sensors shall be provided complete with immersion well. Insertion length shall be at least 150mm. Sensing ranges -40 to $+120^{\circ}\text{C}$.

3. Humidity Sensors:

Humidity sensors shall employ a hygroscopic ribbon as humidity sensing element. Sensors shall have a range of 15-95% RH & shall have NEMA Type 1 location suitability.

4. Air Differential Pressure Switch:

The switch shall sense a change in the differential pressure as air pressure in the ducts, across filter or fan changes. Pressure switch shall have single pole double throw type contacts. Adjustable set point, range scale & metal enclosure with high and low pressure connector ports.

The range shall be 0.05 to 5 inch (12 to 1250 Pa) of water column with 0.04 inch (10 Pa) sensitivity at minimum set point. Differential switch shall be capable to withstand double the pressure of working range. Electrical switch rating shall be minimum 5 Amps at 230 volts.



SPECIFICATIONS

PROJECT NO : 1890
PROJECT TITLE : SSGCL HEAD OFFICE BUILDING, KARACHI
DATED : 20TH APRIL, 2026

5. Buried Steel Piping:

A. The bare steel piping, or the steel cladding of an insulated pipeline shall be externally painted with one coat of Asphalt primer 2000 (National Petrocarbon Pvt. Ltd.) followed by two coats of Hykote Enamel (National Petrocarbon) reinforced with one layer of glass fibre wrap. The primer and enamel shall be applied strictly in accordance with manufacturer's recommendations.

6. Adhesive:

A. shall be "MOWLITH" as manufactured by HOEST, Pakistan.

7. Insulation Tapes:

A. At all insulation joints use 75mm wide self-adhesive tape consisting of reinforced aluminium foil and white Kraft paper.

8. Reference Specification:

A. The following specifications shall be construed to be part of these specifications.

1. 23 05 01 - Basic Mechanical Requirement
2. 23 05 02 - Basic Mechanical Materials and Methods

END OF SECTION 23 07 19



PROJECT NO : 1890
 PROJECT TITLE : SSGCL HEAD OFFICE BUILDING, KARACHI
 DATED : 20TH APRIL, 2026

PIPING INSULATION

(HVAC)

1. Piping Insulation:

- A. **Insulation Installation:** No insulation shall be applied to any system of piping until all foreign matter has been removed from the surface to be insulated, and until the piping has been tested, cleaned out and made tight and painted. All insulation shall be applied in a manner consistent with good practice and methods. All longitudinal joints of pipe shall be top and bottom. Insulation shall be continuous through walls, floors, ceiling and partitions etc.
- B. **Insulation:** All cold & hot water piping shall be insulated as indicated under INSULATION EQUIPMENT DATA SHEET (Section 2). Insulation shall be in preformed sections with tongue and groove attachment. All insulation shall be fixed to the pipe with approved adhesive. Insulation shall be continuous and gaps if any shall be filled up. Circumferential and longitudinal joints of vapour barrier and jacket shall be over-lapped at least 50mm.
- C. **Vapour Barrier:** shall be as specified under INSULATION EQUIPMENT DATA SHEET (Section 2). Vapour barrier shall be fixed to the insulation with approved adhesive covering at least 75% area. All circumferential and longitudinal joints shall be over-lapped at least 40mm. Vapour barrier shall be completely continuous. All scratches, tears, etc., shall be made good by pasting fresh layers of the vapour barrier on the discontinuity.
- D. **Jacket:** shall be as specified under INSULATION EQUIPMENT DATA SHEET (Section 2). All circumferential and longitudinal joints shall be overlapped at least 40mm. The jacket shall be stretched tight over the insulation using adhesive which shall cover 100% area. Cut edges shall not be visible. All longitudinal joints shall be on top for horizontal piping and hidden from view for vertical piping. Circumferential joints shall be equally distant and equal to the width of the jacket roll. Patches shall not be permitted.
- E. **Vapour Barrier Coating:** shall be as specified under INSULATION EQUIPMENT DATA SHEET (Section 2).
- F. **Cladding:** All chilled and hot water piping shall be provided with cladding as specified below.

2. Valves, Fittings & Other Specialities:

- A. shall be insulated with preformed adjoining insulation, cut to suitable shapes and sections, to closely fit around valves and fittings. Insulation thickness shall not be less than the adjoining straight pipe insulation thickness. The adjoining insulation near these fittings shall be mitred and trimmed into suitable sections to fit closely around the valves, flanges and fittings. All trimmed sections shall be secured by wrapping of approved type of self-adhesive tape to form a complete vapour seal. There shall be a clear break between adjoining pipe insulation & valve/specialities insulation; so that when valve/specialities insulation is opened for maintenance the adjoining pre insulation is not affected.

3. Condensate Drains:

- A. shall be insulated as specified under INSULATION EQUIPMENT DATA SHEET (Section 2).

4. Cladding:

- A. All insulated pipes shall be provided with a cladding of 26 gauge 0.55mm G.I. sheet. At all flanges and valves the cladding shall be openable type. Valves shall be provided with valve boxes with quick opening clamps. Large valve boxes may be held together using "Jubilee Clamps".

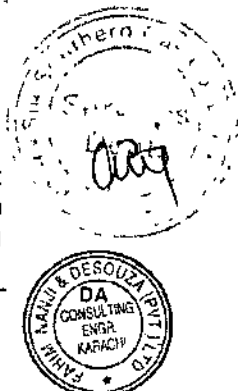

SPECIFICATIONS

PROJECT NO : 1890
PROJECT TITLE : SSGCL HEAD OFFICE BUILDING, KARACHI
DATED : 20TH APRIL, 2026

DUCT WORK INSULATION

1. Insulation:

All supply air ducting and return air ducting shall be insulated with insulation indicated in INSULATION EQUIPMENT DATA SHEET (Section 2). Panels shall be cut to size to fit duct being insulated, and shall be fixed to the duct with approved adhesive. Adhesive shall cover at least 75% of duct area. Sheet metal hooks will not be allowed. The insulation is to be installed flush with the duct, but so as not to lessen the thickness of the insulation. Insulation shall be continuous, and no gaps, crevices, or other discontinuities shall be acceptable. The insulation shall be held in place additionally by using polyethylene packaging bands, 10mm wide.

2. Jacket:

To provide mechanical protection to the insulation shall be provided in mechanical rooms, on ducts which are installed at or below 2m height. Jacket shall be as indicated under INSULATION EQUIPMENT DATA SHEET (Section 2), pasted to insulation using approved adhesive. All circumferential and longitudinal joints shall be over-lapped at least 40mm.

3. Cladding:

All insulated ducting exposed to the atmosphere shall be provided with a cladding of 24 gage (0.70mm) G.I sheet over the insulation. All joints shall be sealed with "Silicon Sealant", so that the cladding becomes completely water-proof. Cladding shall also be installed at all other locations shown on the drawings.

4. Insulation Tapes:

At all insulation joints use 75mm wide self-adhesive tape consisting of reinforced aluminium foil and white Kraft paper.

5. Adhesive:

Adhesive shall be rubber reinforced co-polymeric compound, equivalent in all respects to Zahabiya (Pakistan) ZGPA-7/223.

6. Reference Specification:

The following specifications shall be construed to be part of these specifications.

- 23 05 01 - Basic Mechanical Requirement
- 23 05 02 - Basic Mechanical Materials and Methods

END OF SECTION 23 07 13

SPECIFICATIONS

PROJECT NO : 1890
PROJECT TITLE : SSGCL HEAD OFFICE BUILDING, KARACHI
DATED : 20TH APRIL, 2026

TEST RUN

1. After satisfactory commissioning of the entire system, the Contractor shall carry out a Test Run in summer for a period stated in the BOQ. The Completion Certificate shall be provided on completion of the test run period to the satisfaction of the Engineer and in keeping with the stipulations of relevant clauses of the General and Special Conditions of Contract. This Test Run shall be construed to form a part of the "PERFORMANCE TESTS" specified here in before.
2. If winter heating is specified the Contractor shall return in winter to carry out the heating test run, which shall be conducted for a period indicated in the BOQ.
3. During the Test Run Period the Contractor shall maintain logs of all the operational parameters of all the equipment, & shall also log any operational difficulties/shortages indicated during the Test Run Period. He shall also remove all such deficiencies/shortages immediately to the satisfaction of the Engineer.
4. The format of the log data sheets shall be submitted to the Engineer & approval obtained.
5. The Contractor shall submit the filled logs to the Engineer & Engineer on a daily basis the satisfactory completion of the Test Run.

END OF SECTION 23 05 94

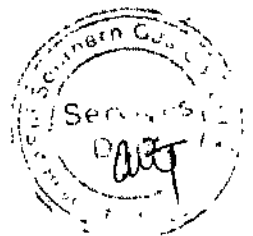

SPECIFICATIONS

PROJECT NO : 1890
PROJECT TITLE : SSGCL HEAD OFFICE BUILDING, KARACHI
DATED : 20TH APRIL, 2026

Cooling Tower: Air quantity in cubic feet per minute at full load operation, entering air dry bulb and wet bulb temperature, leaving air dry bulb and wet bulb temperature, motor load in amperes and voltage.

END OF SECTION 23 05 93



SPECIFICATIONS

PROJECT NO : 1890
PROJECT TITLE : SSGCL HEAD OFFICE BUILDING, KARACHI
DATED : 20TH APRIL, 2026

CLEANING, TESTING, ADJUSTING & BALANCING

Cleaning and Adjusting:

Pipe shall be cleaned free of scale and thoroughly flushed of all foreign matter & further flushed using an approved proprietary chemical used in accordance with manufacturer's recommendations. Temporary bypass shall be provided for all water coils to prevent flushing water from passing through coils. Strainers and valves shall be thoroughly cleaned of all debris and blown free of all small particles of rubbish and dust before installation of outer faces. Equipment shall be wiped clean of all traces of oil, dust and paint spots removed. Temporary filters shall be provided for all fans that are operated during construction, and after all construction dirt has been removed from the building, new filters will be installed. Bearings shall be properly lubricated with oil or grease as per recommendations of the manufacturer. Belts shall be tightened to proper tension. All control valves and other miscellaneous equipment requiring adjustment shall be adjusted to setting indicated or directed. Fans shall be adjusted to speed indicated by the manufacturer to meet the specified conditions.

Balancing:

Water piping system shall be balanced to produce water quantities as indicated with all automatic control valves open. This shall apply to steam piping also.

Duct system shall be balanced to produce air quantities within 5% of that indicated.

Performance Tests:

After cleaning, balancing, and testing operations have been completed, as here in before specified, the system shall be tested as a whole to see that all items perform as an integral part of the system, and that temperature and conditions are evenly controlled throughout the building. Corrections and adjustments shall be made as necessary to produce the conditions indicated, at no additional cost to the Owner.

Test Data:

System test-data shall be obtained by an independent testing agency, arranged by the Owner, who shall provide the Engineer with typewritten schedules of readings taken during the balancing and testing operation for the following items. The Contractor shall be responsible to carry out all rectification measures to adjust and balance the system to provide operation compatible to the design.

Air Balances:

Fans: Size, type, speed in revolutions per minute, static pressure in inches of water, air quantity in cubic feet per minute and motor load in amperes and voltage.

Coils: Size, face velocity in feet per minute, air-condition on-and-off uni-wet-bulb and dry-bulb temperature in °F., water temperature drop through heating/ cooling coil, temperatures entering coil in °F.

Ducts: Size, velocity in feet per minute, and air quantity in ft³/min.

Air Outlets and Inlets: Size, velocity in feet per minute, and air quantity in cubic feet per minute.

Water Balance:

Pumps: GPM, suction head, discharge head, rpm, motor load in amperes and voltage.

Chillers: Evaporator gpm, evaporator pressure drop, evaporator entering and leaving water temperature, condenser gpm, condenser pressure drop, condenser entering and leaving water temperature; power consumption, suction temperature and pressure; discharge temperature and pressure, oil pressure and temperature.

Air Handling Unit/Fan Coil Unit: GPM through each Air Handling Unit/Fan Coil Unit.



SPECIFICATIONS

PROJECT NO : 1890
PROJECT TITLE : SSGCL HEAD OFFICE BUILDING, KARACHI
DATED : 20TH APRIL, 2026

- ii) Near each branch, excluding short take-offs for fixtures and terminal units. Mark each pipe at branch, where flow pattern is not obvious.
- iii) Near locations where pipes pass through walls, floors, ceilings or enter non-accessible enclosures.
- iv) At access doors, manholes and similar access points that permit view of concealed piping.
- v) Near major equipment items and other points of origination and termination.
- vi) Spaced at a maximum of 15 meters intervals along each run. Reduce intervals to 8 meters in congested areas of piping and equipment.
- vii) On piping above removable acoustical ceilings, except omit intermediately spaced markers.

5. Labelling & Identifying Valves:

Identification Tags shall be installed on all valves, controls and other parts of the system where necessary. Tags shall be either of engraved laminated plastic as approved by Engineer, 3mm thick (black in front and white behind) 1.6 inches (40mm) round or square with letters or numbers 0.5 inches (12mm) high and fastened securely with brass "S" hooks or chains.

The Contractor shall further provide charts, diagrams, of size and type as approved designating numbers, service or function and location of each tagged item.

6. Labelling & Identifying Ducts:

- a) Duct Systems: Identify air supply, return, exhaust, intake and relief ducts with stencilled signs and arrows, showing duct system service and direction of flow.
 - i) Location: In each space where ducts are exposed or concealed by removable ceiling system, locate signs near points where ducts enter into space and at maximum intervals of 15 meters.
- b) Adjusting: Relocate identifying devices, which become visually blocked by work of this Division or other Divisions.

END OF SECTION 23 05 53

SPECIFICATIONS

PROJECT NO : 1890
PROJECT TITLE : SSGCL HEAD OFFICE BUILDING, KARACHI
DATED : 20TH APRIL, 2026

MECHANICAL IDENTIFICATION

1. General:

The Contractor shall install mechanical identification tags, shield, plates, etc., where specified below, shown on drawings, or directed by the Engineers. All components of the identification system shall be submitted to the Engineers for approval & approval obtained prior to installation.

2. Manufacturer's Equipment Name Plates:

All equipment shall be provided by manufacturer installed metal nameplate with operational data engraved or stamped; permanently fastened to equipment at an accessible & visible location. Nameplate shall have name of manufacturer, product name, model number, serial number, capacity, operating and power characteristics, labels of tested compliances and similar essential data.

- a) Manufacturer's standard pre-printed, permanent adhesive, color-coded, pressure-sensitive vinyl pipe markers, conforming to ASME A13.1 shall also be accepted.

3. Equipment Data Plates:

(i) Contractor shall install Equipment Data Plates on all equipment; Equipment Data Plates shall be permanently fastened at a suitable accessible and visible location of the equipment. Data plates shall be of minimum 3mm thick laminated plastic of suitable size (min. 150mm x 100mm) fastened securely to the equipment. The plates shall generally display the following data:

- a) Engineer's equipment identification symbol/number.
b) Fluid flow rates.
c) Pressure, pressure drops.
d) Cooling capacities or other capacities.
e) Motor data.
f) Any other matter required by the Engineers.
- (ii) Size of Name Plate: Name plates shall be 200mm x 150mm or as approved by the Engineer.
- (iii) Lettering Size: Main identification letters shall be 20mm high, with smaller size for subsequent text, as approved by the Engineer.
- (iv) Text of Signs: Provide text as approved by the Engineer. Text shall inform operator of operational requirements, indicate safety and emergency precautions and warn of hazards and improper operations, in addition to name of identified unit.

4. Labelling & Identifying Piping:

The Contractor shall attach a stencil near each valve on the pipe, indicating the name of the fluid. Also an arrow should be painted next to the legend indicating the direction of flow in pipe. The legend shall be placed in a location so that it can be easily read from the floor. The legend shall conform in size of letters and colour to ASA A-13.1 of 1975, "Scheme for the Identification of Piping System", but shall not be less than 32mm letters for duct work, and not less than 19mm letters for access door sign & similar operational instructions.

Install pipe markers as follows on each system, wherever piping is exposed in finished spaces, machine rooms, accessible maintenance spaces (shafts, tunnels, plenums) and exterior non-concealed locations. Include arrows showing normal direction of flow:

- i) Near each valve and control device.



SPECIFICATIONS

PROJECT NO : 1890
PROJECT TITLE : SSGCL HEAD OFFICE BUILDING, KARACHI
DATED : 20TH APRIL, 2026

3.2.2 Un-insulated Surfaces

Piping, valves, and fittings, tanks, etc., shall be painted with two coats of primer followed by two coats of enamel paint.

3.2.3 Insulated Surfaces

Piping, valves, fittings, vessels, etc., shall be painted with two coats of primer.

3.2.4 Insulated Piping

Provided with cladding, installed in ceiling cavities & concealed shafts, need not be painted. Exposed insulated piping and piping in Mechanical Equipment Rooms, with or without cladding, shall be painted with galvanising primer and two finish coats of enamel paint.

3.2.5 Galvanised Piping

Exposed to view shall be painted with special primer and two coats of enamel paint.

3.2.6 Hangers & Supports

All supports shall be hot-dipped galvanised, and need not be painted.

3.2.7 Copper piping

Copper piping shall not be painted.

3.3 Surface Preparation:

- Surface to be painted shall be dry and free from burrs, weld spatter, flux, dirt, dust, rust, loose mill scale, grease, oil and other foreign matter before any paint is applied.
- All rust and loose mill scale etc. shall be removed by thoroughly chipping, scraping and wire brushing. Oil, grease, dust etc. shall be removed by washing down with a suitable solvent, as recommended by the paint manufacturer, and wiping with clean rags.
- The minimum acceptable standard for surface preparation shall be SSPC-SP2, 'Hard Tool Cleaning'.
- All tools shall be used in such a manner so as not to leave rough or sharp surfaces. No cuts shall be made on steel surfaces.
- Before applying the finish coat the primed surface shall be scuffed lightly with sand paper recommended by the paint manufacturer.

3.4 Field Quality Control:

Perform Work in accordance with relevant paint manufacturer's recommendations. Ensure that surface preparation is properly done and get Engineer's approval before painting. Also get approval after each coat of paint is completed.

3.5 Reference Specification:

The following specifications shall be construed to be part of these specifications.

- 23 05 01 – Basic Mechanical Requirement
- 23 05 02 – Basic Mechanical Materials and Methods

END OF SECTION 23 05 50

SPECIFICATIONS

PROJECT NO : 1890
PROJECT TITLE : SSGCL HEAD OFFICE BUILDING, KARACHI
DATED : 20TH APRIL, 2026

- d) All paint supplied from factory shall be ready for application. The application of thinners or any other material shall be subject to approval by the Engineer. In any case all instructions of the paints manufacturer shall be strictly followed.

2.2 Galvanising:

- a) Galvanising shall comply with BS 729. The term 'galvanised' shall apply to hot dip or electrolytic galvanising, zinc spraying or cadmium plating. All surfaces shall be degreased, washed with mineral turpentine and given a coat of latex based primer prior to the application of final coats.
- b) After fabrication, pickle or abrasive blast clean all steelworks to be hot dipped galvanized.

2.3 Powder Coating:

- a) All surfaces to be powder coated shall be cleaned as for galvanising. Powder shall be applied by using an electrostatic gun in a clean atmosphere to ensure that no dust particles or other impurities blemish the final product.
- b) Coated components shall be baked in special ovens at controlled and accurately predetermined temperatures, and powder applied to a thickness of 0.0125mm on wearing surfaces and 0.01mm on non-wearing surfaces, unless otherwise specified.

PART-3: EXECUTION

3.1 General:

- a) All material shall be applied in strict accordance with the paint manufacturer's directions unless otherwise specified.
- b) Paint shall be applied by brush, spray or any other paint manufacturer's approved method in such a manner that a uniform thickness (as per manufacturer's recommendation) is maintained in each coat and no defects are produced in the previous coats.
- c) Each coat shall preferably be of a different colour so as to produce a contrast assuring complete covering by the next coat. Sufficient time shall be allowed between coats to permit drying. A minimum of 24 hours between applications on any one surface shall be allowed unless otherwise specified by the manufacturer.
- d) No painting work shall be done on exterior surfaces during rainy, damp, foggy or dusty weather and no painting material shall be applied if the temperature is above 122°F (50°C) or below 41°F (5°C). Painting work shall be avoided in cases where the surface is damp or when there is dirt and dust deposition due to blowing winds. The Owner's representative shall determine whether the conditions are suitable for painting or not.
- e) The primer coat of paint shall be applied as soon as possible after the surface preparation but, in any case, on the same day.
- f) Before application of painting material, the Company/Engineer's representative shall inspect and approve the quality of surface preparation and the preparation of painting material.

3.2 Paint System:

3.2.1 Materials & Equipment

All materials & equipment factory fabricated, imported or otherwise shall be provided with a fresh coat of paint of same colour as the original factory paint, if in the opinion of the Engineer the same has deteriorated to an extent to require fresh painting. Paint shall be applied as per the accepted norms and as directed by the Engineer.



SPECIFICATIONS

PROJECT NO : 1890
PROJECT TITLE : SSGCL HEAD OFFICE BUILDING, KARACHI
DATED : 20TH APRIL, 2026

PAINTING AND COATING

PART-1: GENERAL

1.1 System Description:

- a) Furnish labour, materials, equipment, ladders, scaffolding, protective covers, other items required to prepare and finish surfaces of work specified herein or in any of the other sections.
- b) Paint colour scheme shall be specified at the time of painting or earlier and shall be based on American Standard "Scheme for Identifications of Piping System" ASA A-13.1 of 1975 & shown on FND detail drawing no: FND/D/57 & 58, which form part of these specifications.

1.2 Submittals:

1.2.1 Tendering Stage Submittals

Bidder shall submit all required documentation to establish conformance to specifications, as indicated in Section-23 05 02, Clause 1.4, as well as any special requirements noted below.

1.2.2 Technical Approval Stage Submittals

Contractor shall submit all required documentation to establish conformance to specifications, as indicated in Section-23 05 02, Clause 1.4, as well as any special requirements noted below.

1.2.3 Construction Stage Submittals

Contractor shall submit all required documentation to establish conformance to specifications, as indicated in Section-23 05 02, Clause 1.4, as well as any special requirements noted below:

- Sample of pipe, with paint & coatings applied. The sample shall show progressive application of layers with colour added to show separate layers. The preparing of piping surface, as specified, shall also be shown.

1.2.4 Close-Out Submittals

Contractor shall submit all required documentation to establish conformance to specifications, as indicated in Section-23 05 02, Clause 1.4, as well as any special requirements noted below.

1.3 Delivery, Storage, and Handling:

Paint and coatings shall be stored in accordance with the manufacturer's recommendations. Care shall be taken as all paints and coatings are inflammable.

1.4 Warranty:

Contractor shall guarantee the paint work carried out against defects in materials and/or workmanship for a period of one year from date of Substantial Completion.

PART-2: PRODUCTS

2.1 Paint:

- a) Primer for Iron Surfaces shall be Dulux Synthetic Red Primer as manufactured by ICI. This shall be Lead free.
- b) Primer for Galvanised Surfaces shall be ETCH PRIMER AND "ZINC CHROMATE YELLOW PRIMER" as manufactured by ICI.
- c) Finishing Paint shall be generally enamel paint, unless the application requires special paint, in which case suitable special paint shall be used.



SPECIFICATIONS

PROJECT NO : 1890
PROJECT TITLE : SSGCL HEAD OFFICE BUILDING, KARACHI
DATED : 20TH APRIL, 2026

2. All clevis or trapeze supported conduits suspended by hanger rods where the point of attachment is less than 12" in length from the structure to the structural connection of the clevis or trapeze.

D. Suspended Equipment

1. VAV boxes and fan powered equipment weighing less than 50lbs. And rigidly connected to the supply side of the duct system and supported with a minimum of 4 hanger rods.

END OF SECTION 23 05 49



SPECIFICATIONS

PROJECT NO : 1890
PROJECT TITLE : SSGCL HEAD OFFICE BUILDING, KARACHI
DATED : 20TH APRIL, 2026

F. Seismic Restraint of Electrical Services:

1. All electrical conduit 2½" in diameter and larger shall be restrained with specification type 12 seismic cable restraints or specification type 13 for seismic solid brace restraints.
 2. All electrical bus ducts, cable trays and ladder trays shall be restrained with specification type 12, seismic cable restraints or specification 13 seismic solid brace restraints.
 3. Transverse restraints shall occur at 30' intervals or both ends if the electrical run is less than the specified interval. Transverse restraint shall be installed at each electrical services turn and at each end of the electric run.
 4. Longitudinal restraints shall occur at 60' intervals with at least one restraint per electric run. Transverse restraints for one electric section may also act as a longitudinal restraint for a duct for an electric section connected perpendicular to it if the restraints are installed within 4' of the intersection of the electric run and if the restraints are sized for the larger electric run.
 5. All rigid floor mounted equipment must have a resilient media between the equipment mounting hole and the anchor bolt. Anchor bolts shall be designed in accordance with section 1.06 seismic forces. Neoprene bushings shall be specification type 4 and anchor bolts shall be specification type 18 or 19.
 6. Wall mounted panels shall be mounted with specification type 3 bushings. Floor mounted panels shall be mounted on specification type 4 bushings. Anchor bolts shall be specification type 18 or 19.
- G. All fire protection piping shall be braced in accordance with NEPA-13 & 14.
- H. All mechanical equipment shall be vibration isolated and seismically restrained as per the schedules in part 4 of this specification.
- I. All fire protection equipment is considered life safety equipment and shall be seismically restrained using the seismic force levels for life safety equipment in Table 1.06-1. If higher levels are shown.

3.03 Seismic Restraint Exclusions:

A. Piping

1. All piping less than 2½" in diameter except those listed below.
2. All gas piping and medical gas piping less than 1" I.D.
3. All piping in boiler and mechanical equipment rooms less than 1¼" I.D.
4. All clevis or trapeze supported piping suspended from hanger rods where the point of attachment is less than the 12" in length from the structure to the structural connection of the clevis or trapeze.
5. All PVC and fibreglass suspended waste or vent pipe 6" in diameter and smaller.

B. Duct Work

1. Rectangular, square or oval ducts less than 6 sq.ft in cross sectional area.
2. Round duct less than 28" in diameter.
3. Duct supported by hanger rods where the point of attachment is less than 12" in length from the structure to the structural connection of the duct work.

C. Electrical

1. All conduits less than 2½" diameters suspended by individual hanger rods.



SPECIFICATIONS

PROJECT NO : 1890
PROJECT TITLE : SSGCL HEAD OFFICE BUILDING, KARACHI
DATED : 20TH APRIL, 2026

greater than the restraint loads in addition to the loads induced by expansion or contraction.

5. For fuel oil and all gas piping transverse restraints must be at 20' maximum and longitudinal restraints at 40' maximum spacing.
6. Transverse restraint for one pipe section may also act as a longitudinal restraint for a pipe section of the same size connected perpendicular to it if the restraint is installed within 24" of the elbow or TEE or combined stresses are within allowable limits at longer distances.
7. Hold down clamps must be used to attach pipe to all trapeze members before applying restraints in a manner similar to clevis supports.
8. Branch lines may not be used to restrain main lines.
9. Cast iron pipe of all types, glass pipe and any other pipes joined with a four band shield and clamp assembly in Zones 2B, 3 and 4 shall be braced as in sections 3.02.C.2 and 3. For Zones 0, 1 and 2A, 2 band clamps may be used with reduced spacing's of ½" of those listed in sections 3.02.C.2 and 3.

D. Vibration Isolation of Ductwork:

1. All discharge runs for a distance of 50' from the connected equipment shall be isolated from the building structure by means of specification 10 hangers or specification 5 floor isolators. Spring deflection shall be a minimum of 0.75.
2. All duct runs having air velocity of 1000 fpm or more shall be isolated from the building structure by specification 11 hangers or 5 floor supports. Spring deflection shall be a minimum of 0.75.

E. Seismic Restraint of Ductwork:

1. Seismically restrain all duct work with specification 12 or 13 restraints as listed below:
 - a. Restrain rectangular ducts with cross sectional area of 6 sq.ft. or larger.
 - b. Restrain round ducts with diameters of 28" or larger.
 - c. Restrain flat oval ducts the same as rectangular ducts of the same nominal size.
2. Transverse restraints shall occur at 30' intervals or at both ends of the duct run if less than the specified interval. Transverse restraints shall be installed at each duct turn and at each end of a duct run.
3. Longitudinal restraints shall occur at 60' intervals with at least one restraint per duct run. Transverse restraints for one duct section may also act as a longitudinal restraint for a duct section connected perpendicular to it if the restraints are installed within 4' of the intersection of the ducts and if the restraints are sized for the larger duct. Duct joints shall conform to SMACNA duct construction standards.
4. The ductwork must be reinforced at the restraint locations. Reinforcement shall consist of an additional angle on top of the ductwork that is attached to the support hanger rods. Ductwork is to be attached to both upper angle and lower trapeze.
5. A group of ducts may be combined in a larger frame so that the combined weights and dimensions of the ducts are less than or equal to the maximum weight and dimensions of the duct for which bracing details are slotted.
6. Walls, including gypsum board non-bearing partitions, which have ducts running through them, may replace a typical transverse brace. Provide channel framing around ducts and solid blocking between the duct and frame.



SPECIFICATIONS

PROJECT NO : 1890
PROJECT TITLE : SSGCL HEAD OFFICE BUILDING, KARACHI
DATED : 20TH APRIL, 2026

30. Horizontal thrust restraint shall consist of a spring element in series with a neoprene molded cup as described in specification 5 with the same deflection as specified for the mountings or hangers. The spring element shall be designed so it can be preset for thrust at the factory and adjusted in the field to allow for a maximum of ¼" movement at start and stop. The assembly shall be furnished with 1 rod and angle brackets for attachment to both the equipment and the duct work or the equipment and the structure. Horizontal restraints shall be attached at the centreline of thrust and symmetrical on either side of the unit. Horizontal thrust restraints shall be type WBI/WBD as manufactured by Mason Industries, Inc.

PART 3 - EXECUTION

3.01 General:

- A. All vibration isolators and seismic restraint systems must be installed in strict accordance with the manufacturers written instructions and all certified submittal data.
- B. Installation of vibration isolators and seismic restraints must not cause any change position of equipment, piping or duct work resulting in stresses or misalignment.
- C. No rigid connections between equipment and the building structure shall be made that degrades the noise and vibration control system herein specified.
- D. The contractor shall not install any equipment, piping, duct or conduit, which makes rigid connections with the building unless isolation is not specified. "Building" includes, but is not limited to, slabs, beams, columns, studs and walls.
- E. Coordinate work with other trades to avoid rigid contact with the building.
- F. Any conflicts with other trades which will result in rigid contact with equipment or piping due to inadequate space or other unforeseen conditions should be brought to the architects/engineers attention prior the installation. Corrective work necessitated by conflicts after installation shall be at the responsible contractor's expense.
- G. Bring to the architects/engineers attention any discrepancies between the specifications and the field conditions or changes required due to specific equipment selection, prior to installation. Corrective work necessitated by discrepancies after installation shall be at the responsible contractor's expense.
- H. Correct, at no additional cost, all installations which are deemed defective in workmanship and materials at the contractor's expense.
- I. Overstressing of the building structure must not occur because of overhead support of equipment. Contractor must submit loads to the structural engineer all records for approval. Generally bracing may occur from:
 - a. Flanges of structural beams
 - b. Upper truss cords in bar joist construction.
 - c. Cast in place inserts or wedge type drill-in concrete anchors.
- J. Specification 12 cable restraints shall be installed slightly slack to avoid short circuiting the isolated suspended equipment, piping or conduit.
- K. Specification 12 cable assemblies are installed taut on non-isolated systems. Specification 13 seismic solid braces may be used in place of cables on rigidly attached systems only.
- L. At locations where specification 12 or 13 restraints are located, the support rods must be braced when necessary to accept compressive loads with specification 14 braces.
- M. At all locations where specification 12 or 13 restraints are attached to pipe clevis's, the clevis cross bolt must be reinforced with specification type 15 braces.



SPECIFICATIONS

PROJECT NO : 1890
PROJECT TITLE : SSGCL HEAD OFFICE BUILDING, KARACHI
DATED : 20TH APRIL, 2026

retention. 14" and allowable pressure to 190 psi at 250°F. 16" and larger connectors are rated 180 psi at 190°F and 135 psi at 250°F. Safety factors to burst and flange pullout shall be a minimum of 3/1. All joints must have permanent markings verifying a 5 minute factory test at twice the rated pressure. Concentric reducers to the above specifications may be substituted for equal ended expansion joints.

- 24. Expansion joints shall be installed in piping gaps equal to the length of the expansion joints under pressure. Control rods need only be used in unanchored piping locations where the manufacturer determines the installation exceeds the pressure requirement without control rods, as control rods are not desirable in seismic work. If control rods are used, they must have ½" thick Neoprene washer bushings large enough in area to take the thrust at 1000 psi maximum on the washer area. Expansion joints shall be installed on the equipment side of the shut off valves.
- 25. Submittals shall include two test reports by independent Engineers showing minimum reductions of 20 DB in vibration accelerations and 10 DB in sound pressure levels at typical blade passage frequencies on this or a similar product by the same manufacturer. All expansion joints shall be installed on the equipment side of the shut off valves. Expansion joints shall be SAFEFLEX SFDEJ, SFEJ, SFDCR or SFU and Control Rods CR as manufactured by Mason Industries, Inc.
- 26. Flexible stainless steel hose shall have stainless steel braid and carbon steel fittings. Sizes 3" and larger shall be flanged. Smaller sizes shall have male nipples. Minimum lengths shall be as tabulated: All dimensions in inches.

Flanged		Male Nipples	
3 x 14	10 x 26	½" x 9	1½" x 13
4 x 15	12 x 28	¾" x 10	2 x 14
5 x 19	14 x 30	1 x 11	2½" x 18
6 x 20	16 x 32	1¼" x 12	
8 x 22			

Hoses shall be installed on the equipment side of the shut-off valves horizontally and parallel to the equipment shafts wherever possible. Hoses shall be type BSS as manufactured by Mason Industries, Inc.

- 27. All directional acoustical pipe anchor, consisting of two sizes of steel tubing separated by a minimum ½" thick 60 durometer neoprene. Vertical restraint shall be provided by similar material arranged to prevent vertical travel in either direction. Allowable loads on the isolation material should not exceed 500 psi and the design shall be balanced for equal resistance in any direction. All directional anchors shall be type ADA as manufactured by Manson Industries, Inc.
- 28. Pipe guides shall consist of a telescopic arrangement of two sizes of steel tubing separated by a minimum ½" thickness of 60 durometer neoprene. The height of the guides shall be preset with a shear pin to allow vertical motion due to pipe expansion or contraction. Shear pin shall be removable and reinsertable to allow for selection of pipe movement. Guides shall be capable of ±1⅝" motion, or to meet location requirements. Pipe guides shall be type VSG as manufactured by Mason Industries, Inc.
- 29. Split Wall seals consist of two bolted pipe halves with minimum ¾" thick neoprene sponge bonded to the inner faces. The seal shall be tightened around the pipe to eliminate clearance between the inner sponge face and the piping. Concrete may be packed around the seal to make it integral with the floor, wall or ceiling if the seal is not already in place around the pipe prior to the construction of the building member. Seals shall project a minimum of 1" past either face of the wall. Where temperatures exceed 240°F, 10# density fibreglass may be used in lieu of the sponge. Seals shall be type SWS as manufactured by Mason Industries, Inc.



SPECIFICATIONS

PROJECT NO : 1890
PROJECT TITLE : SSGCL HEAD OFFICE BUILDING, KARACHI
DATED : 20TH APRIL, 2026

have a safety shoulder which fully supports the wedge ring under load. The stud anchors shall have an evaluation report snubber form the I.C.B.O. Evaluation service, Inc. verifying its allowable loads. Drill-in stud wedge anchors shall be type SAS as manufactured by Mason Industries, Inc.

19. Female wedge anchors are preferred in floor locations so isolators or equipment can be slid into place after the anchors are installed. Anchors shall be manufactured from full diameter wire, and shall have a safety shoulder to fully support the wedge ring under load. Female wedge anchors shall have an evaluation report number from the I.C.B.O. Evaluation service, Inc. verifying its allowable loads. Drill-in female wedge anchors shall be type SAB as manufactured by Mason Industries, Inc.
20. Vibration isolation manufacturer shall furnish integral structural steel bases. Rectangular bases are preferred for all equipment. Centrifugal refrigeration machines and pump bases may be T or L shaped where space is a problem. Pump bases for split case pump shall include supports for suction and discharge elbows. All perimeter members shall be steel beams with a minimum depth equal to $1/10$ " of the longest dimension of the base. Base depth need not exceed 14 provided that the deflection and misalignment is kept within acceptable limits as determined by the manufacturer. Height saving brackets shall be employed in all mounting locations to provide a base clearance of 1". Bases shall be type WF as manufactured by Mason Industries, Inc.
21. Vibration isolation manufacturer shall furnish rectangular steel concrete pouring forms for floating and inertia foundations. Bases for split case pumps shall be large enough to provide for suction and discharge elbows. Bases shall be a minimum of $1/12$ f the longest dimension of the base but no less than 6". The base depth need not exceed 12" unless specifically recommended by the base manufacturer for mass or rigidity. Forms shall include minimum concrete reinforcing consisting of $1/2$ " bars welded in place on 6" centres running both ways in a layer $1 1/2$ " above the bottom. Forms shall be furnished with steel templates to hold the anchor bolts sleeves and anchors while concrete is being poured. Height saving brackets shall be employed in all mounting locations to maintain a 1" clearance below the base. Wooden formed bases leaving a concrete rather than a steel finish are not acceptable. Base shall be type BMK or K as manufactured by Mason Industries, Inc.
22. Curb mounted rooftop equipment shall be mounted on spring isolation curbs. The lower member shall consist of a sheet metal Z section containing adjustable and removable steel springs that support the upper floating section. The upper frame must provide continuous support for the equipment and must be captive so as to resiliently resist wind and seismic forces. All directional neoprene snubber bushings shall be a minimum of $1/4$ " thick. Steel springs shall be laterally stable and rest on $1/4$ " thick rust resistant finish. The curbs waterproofing shall consist of a continuous galvanized flexible counter flashing nailed over the lower curbs waterproofing and joined at the corners by EPDM bellows. All spring locations shall have access ports with removable waterproof covers. Lower curbs shall have provision for 2" of insulation. The roof curbs shall be built to seismically contain the rooftop unit. The unit must be solidly fastened to the top floating rail, and the lower Z section anchored to the roof structure. Curb shall have anchorage preapproval "R" from OSHPD in the state of California attesting to the maximum certified horizontal and vertical load ratings. Curb shall be type RSC as manufactured by Mason Industries, Inc.
23. Flexible spherical expansions joints shall employ peroxide cured EPDM in the covers liners and Dacron tire cord fractioning. Solid steel rings shall be used within the raised face rubber ends to prevent pull-out. Flexible cable bead wire is not acceptable. Sizes 2" and larger shall have two spheres reinforced with a ring between spheres to maintain shape and complete with split ductile iron or steel flanges with hooked or similar interlocks. Sizes 16" to 24" may be single sphere. Sizes $3/4$ " to $1 1/2$ " may have threaded bolted flange assemblies, one sphere and cable

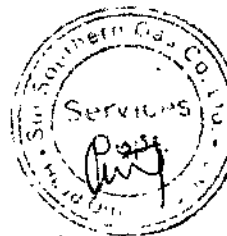

SPECIFICATIONS

PROJECT NO : 1890
PROJECT TITLE : SSGCL HEAD OFFICE BUILDING, KARACHI
DATED : 20TH APRIL, 2026

to final installation angle and utilize two clamping bolts to provide proper cable engagement. Cables must not be allowed to bend across sharp edges. Cable assemblies shall have an Anchorage Preapproval "R" number from OSHPD in the State of California verifying the maximum certified load ratings. Cable assemblies shall be type SCB at the ceiling and at the clevis bolt, SCBH between the hanger rod nut and the clevis or SCBV if clamped to a beam all as manufactured by Mason Industries, Inc.

13. Seismic solid braces shall consist of steel angles or channels to resist seismic loads with a minimum safety factor of 2 and arranged to provide all directional restraint. Seismic solid brace end connectors shall be steel assemblies that swivel to the final installation angle and utilize two through bolts to provide proper attachment. Seismic solid brace assembly shall have anchorage preapproval "R" number form OSHPD in the state of California verifying the maximum certified load ratings. Solid seismic brace assemblies shall be type SSB as manufactured by Mason Industries, Inc.

Note: Specifications 12-14 apply to trapeze as well as clevis hanger locations. At trapeze anchor locations piping must be shackled to the trapeze. Specifications apply to hanging equipment as well.

14. Steel angles, sized to prevent buckling, shall be clamped to pipe or equipment rods utilizing a minimum of three ductile iron clamps at each restraint location when required. Welding of support rods is not acceptable. Rod clamp assemblies shall have an Anchorage Preapproval "R" number from OSHPD in the state of California. Rod clamp assemblies shall be type SRC as manufactured by Mason Industries, Inc.
15. Pipe clevises cross bolt braces are required in all restraint locations. They shall be special purpose preformed channels deep enough to be held in place by bolts passing over the cross bolt. Clevis cross braces shall have an Anchorage Preapproval "R" number OSHPD in the state of California. Clevis cross brace shall be type CCB as manufactured by Mason Industries, Inc.
16. All directional seismic snubbers shall consist of interlocking steel members restrained by a one-piece molded neoprene bushing of bridge bearing neoprene. Bushing shall be replaceable and a minimum of ¼" inch thick. Rated loadings shall not exceed 1000 psi. A minimum air gap of ⅛" inch shall be incorporated in the snubber design in all directions before contact is made between the rigid and resilient surfaces. Snubber end caps shall be removable to allow inspection of internal clearances. Neoprene bushings shall be rotated to insure no short circuits exist before systems are activated. Snubbers shall have an Anchorage Preapproval "R" number OSHPD in the state of California verifying the maximum certified horizontal and vertical load ratings. Snubber shall be type Z-1225 as manufactured by Mason Industries, Inc.
17. All directional seismic snubbers shall consist of interlocking steel members restrained by shock absorbent rubber materials compounded to bridge bearing specifications. Elastomeric materials shall be replaceable and a minimum of ¾" thick. Rated loadings shall not exceed 1000 psi. snubbers shall be manufactured with an air gap between hard and resilient material of not less than ⅛" nor more than ¼". Snubbers shall be installed with factory set clearances. The capacity of the seismic snubber at ⅝" deflections shall be equal or greater than the load assigned to the mounting grouping controlled by the snubber multiplied by the applicable "G" force. Submittals shall include the load deflection curves up to ½" deflection in the X, Y and Z planes. Snubbers shall have an anchorage preapproval "R" number from OSHPD in the state of California verifying the maximum certified horizontal and vertical load ratings. Snubber shall be type Z-1011 as manufactured by Mason Industries, Inc.

18. Stud wedge anchors shall be manufactured form full diameter wire, not from undersized wire that is "roled up" to create the thread. The stud anchor shall also



SPECIFICATIONS

PROJECT NO : 1890
PROJECT TITLE : SSGCL HEAD OFFICE BUILDING, KARACHI
DATED : 20TH APRIL, 2026

operating heights are equal. A minimum clearance of $\frac{1}{2}$ " shall be maintained around restraining bolts and between the housing and the spring so as not to interfere with the spring action. Limit stops shall be out of contact during normal operation. Since housings will be bolted or welded in position there must be an internal isolation pad. Housing shall be designed to resist all seismic forces. Mountings shall have Anchorage Preapproval "R" Number from OSHPD in the state of California certifying the maximum certified horizontal and vertical load ratings. Mountings shall be SLR as manufactured by Mason Industries, Inc.

7. Spring mountings as in specification 5 built into a ductile iron or steel housing to provide all directional seismic snubbing. The snubber shall be adjustable vertically and allow a maximum of $\frac{1}{4}$ " inch travel in all directions before contacting the resilient snubbing collars. Mountings shall have an Anchorage Preapproval "R" number from OSHPD in the State of California verifying the maximum certified horizontal and vertical load ratings. Mountings shall be SSLFH as manufactured by Mason Industries, Inc.
8. Air springs shall be manufactured with upper and lower steel sections connected by a replaceable flexible nylon reinforced neoprene element. Air spring configuration shall be multiple bellows to achieve a maximum natural frequency of 3 Hz. Air Springs shall be designed for a burst pressure that is a minimum of three times the published maximum operating pressure. All air spring systems shall be connected to either the building control air or a supplementary air supply and equipped with three levelling valves to maintain levelling within plus or minus $\frac{1}{8}$ ". Submittals shall include natural frequency, load and damping tests performed by an independent lab or acoustician. Air Springs shall be type MT and levelling valves type LV as manufactured by Mason Industries, Inc.
9. Restrained air spring mountings shall have an MT air spring as described in specification 8, within a rigid housing that includes vertical limit stops to prevent air spring extension when weight is removed. The housing shall serve as blocking during erection. A steel spacer shall be removed after adjustment. Installed and operating heights are equal. A minimum clearance of $\frac{1}{2}$ " shall be maintained around restraining bolts and between the housing and the air spring so as not to interfere with the air spring action. Limit stops shall be out of contact during normal operation. Housing shall be designed to resist all seismic forces. Mountings shall be SLR-MT as manufactured by Mason Industries, Inc.
10. Hangers shall consist of rigid steel frames containing minimum $1\frac{1}{4}$ " thick neoprene elements at the top and a steel spring with general characteristics as in specification 5 seated in a steel washer reinforced neoprene bushings projecting through the steel box. To maintain stability the boxes shall not be articulated as clevis hangers nor the neoprene element stacked on top of the spring. Spring diameters and hanger box lower hole sizes shall be large enough to permit the hanger rod to swing through a 30° arc from side to side before contacting the rod bushing and short circuiting the spring. Submittals shall include a hanger drawing showing the 30° capability. Hangers shall be type 30N as manufactured by Mason Industries, Inc.
11. Hangers shall be as described in 10, but they shall be pre-compressed and locked at the rated deflection by means of a resilient seismic unstop to keep the piping or equipment at a fixed elevation during installation. The hangers shall be designed with a release mechanism to free the spring after the installation is complete and the hanger is subjected to its full load. Deflection shall be clearly indicated by means of a scale. Submittals shall include a drawing of the hanger showing the 30 degree capability. Hangers shall be type PC30N as manufactured by Mason Industries, Inc.
12. Seismic Cable Restraints shall consist of galvanized steel aircraft cables sized to resist seismic loads with a minimum safety factor of two and arranged to provide all-directional restraint. Cable and connections shall be steel assemblies that swivel



PROJECT NO : 1890
 PROJECT TITLE : SSGCL HEAD OFFICE BUILDING, KARACHI
 DATED : 20TH APRIL, 2026

PART 2 – PRODUCTS

2.01 Intent:

- A. All vibration isolators and seismic restraints described in this section shall be the product of a single manufacturer. Mason Industry's products are the basis of these specifications; products of other manufacturers are acceptable provided their systems strictly comply with the specification and have the approval of the specifying engineer. Submittals and certification sheets shall be in accordance with section 1.02.
- B. For the purposes of this project, failure is defined as the discontinuance of any attachment point between equipment and structure, vertical permanent deformation greater than 1/8" inch and/or horizontal permanent deformation greater than 1/4" inch.

2.02 Product Descriptions:

- A. Vibration Isolators and Seismic Restraints Specifications.
 - 1. Two layers of 3/4" thick neoprene pad consisting of 2" square waffle modules separated horizontally by a 16 gauge galvanized shim. Load distribution plates shall be used as required. Pads shall be Type Super "W" as manufactured by Mason Industries, Inc.
 - 2. Bridge-bearing neoprene mountings shall have a minimum static deflection of 0.2" and all directional seismic capability. The mount shall consist of a ductile iron casting containing two separated and opposing molded neoprene elements. The elements shall prevent the central threaded sleeve and attachment bolt from contacting the casting during normal operation. The shock absorbing neoprene materials shall be compounded to bridge-bearing specifications. Mountings shall have an Anchorage Preapproval "R" Number form OSHPD in the State of California verifying the maximum certified horizontal and vertical load ratings. Mountings shall be Type BR as manufactured by Mason Industries, Inc.
 - 3. Sheet metal panels shall be bolted to the walls or supporting structure by assemblies consisting of a neoprene bushing cushioned between 2 steel sleeves. The outer sleeve prevents the sheet metal from cutting into the neoprene. Enlarge panel holes as required. Neoprene elements pass over the bushing to cushion the back panel horizontally. A steel disc covers the inside neoprene element and the inner steel sleeve is elongated to act as a stop so tightening the anchor bolts does not interfere with panel isolation in 3 planes. Bushing assemblies can be applied to the ends of steel cross members where applicable. All neoprene shall be bridge bearing quality. Bushing assemblies shall be type PB as manufactured by Mason Industries, Inc.
 - 4. A one piece molded bridge bearing neoprene washer/bushing. The bushing shall surround the anchor bolt and have a flat washer face to avoid metal to metal contact. Neoprene bushings shall be type HG as manufactured by Mason Industries, Inc.
 - 5. Spring isolators shall be free standing and laterally stable without any housing and complete with a molded neoprene cup or 1/4" neoprene acoustical friction pad between the baseplate and the support. All mountings shall have leveling bolts that must be rigidly bolted to the equipment. Spring diameters shall be no less than 0.8 of the compressed height of the spring at rated load. Springs shall have minimum additional travel to solid? Equal to 50% of the rated deflection. Submittals shall include spring diameters, deflection, compressed spring height and solid spring height. Mountings shall be type SLF as manufactured by Mason Industries, Inc.
 - 6. Restrained spring mountings shall have an SLF mounting as described in Specification 5, within a rigid housing that includes vertical limit stops to prevent spring extension when weight is removed. The housing shall serve as blocking during erection. A steel spacer shall be removed after adjustment. Installed and



SPECIFICATIONS

PROJECT NO : 1890
PROJECT TITLE : SSGCL HEAD OFFICE BUILDING, KARACHI
DATED : 20TH APRIL, 2026

C. Attachments

1. Contactor shall supply restraint attachment plates cast into housekeeping pads, concrete inserts, double sided beam clamps, etc. in accordance with the requirements of the vibration vendor's calculations.

1.06 Seismic Force Levels:

A. The following force levels will be used on this project based on IBC-2000, IBC-2003, TI-809-04 and NFPA-5000.

Table 1.06-1

MINIMUM F_D (G's) FORCES EQUAL TO OR EXCEEDING BUILDING CODE LISTED IN 1.03

IBC 2000 TI-809-04	IBC-2003/NFPA-5000	G ₁ Forces for all pipe, ducts & conduit		G ₁ Forces for Rigidly Mounted Equipment		G ₁ Forces for Vibration Isolated Equipment & Pipe		G ₁ Forces for Low Deformability Pipe	
		Horiz.	Vert.	Horiz.	Vert.	Horiz.	Vert.	Horiz.	Vert.
Lower Levels & Ground Level	Ss less than 0.15	0.08	0.05	0.08	0.05	0.10	0.05	0.08	0.05
	Ss between 0.15 & 0.25	0.13	0.08	0.13	0.08	0.17	0.08	0.13	0.08
	Ss between 0.26 & 0.50	0.17	0.11	0.17	0.11	0.23	0.11	0.18	0.11
	Ss between 0.51 & 1.00	0.22	0.15	0.22	0.15	0.29	0.15	0.23	0.15
	Ss greater than 1.50	0.30	0.20	0.30	0.20	0.40	0.20	0.32	0.20
Above Ground Level up to ¼ of the Height of Building	Ss less than 0.15	0.08	0.05	0.08	0.05	0.15	0.05	0.12	0.05
	Ss between 0.15 & 0.25	0.13	0.08	0.13	0.08	0.25	0.08	0.20	0.08
	Ss between 0.26 & 0.50	0.17	0.11	0.17	0.11	0.34	0.11	0.27	0.11
	Ss between 0.51 & 1.00	0.22	0.15	0.22	0.15	0.44	0.15	0.35	0.15
	Ss greater than 1.50	0.30	0.20	0.30	0.20	0.60	0.20	0.48	0.20
Above ¼ up to ½ of the Height of the Building	Ss less than 0.15	0.08	0.05	0.08	0.05	0.20	0.05	0.16	0.05
	Ss between 0.15 & 0.25	0.13	0.08	0.13	0.08	0.34	0.08	0.27	0.08
	Ss between 0.26 & 0.50	0.17	0.11	0.18	0.11	0.46	0.11	0.36	0.11
	Ss between 0.51 & 1.00	0.22	0.15	0.23	0.15	0.58	0.15	0.47	0.15
	Ss greater than 1.50	0.30	0.20	0.32	0.20	0.80	0.20	0.64	0.20
Above ½ up to ¾ of the Height of the Building	Ss less than 0.15	0.08	0.05	0.10	0.05	0.25	0.05	0.20	0.05
	Ss between 0.15 & 0.25	0.13	0.08	0.17	0.08	0.42	0.08	0.34	0.08
	Ss between 0.26 & 0.50	0.17	0.11	0.23	0.11	0.57	0.11	0.46	0.11
	Ss between 0.51 & 1.00	0.22	0.15	0.29	0.15	0.73	0.15	0.58	0.15
	Ss greater than 1.50	0.30	0.20	0.40	0.20	1.00	0.20	0.80	0.20
Above ¾ of the Height of Building up to the Roof	Ss less than 0.15	0.09	0.05	0.12	0.05	0.30	0.05	0.24	0.05
	Ss between 0.15 & 0.25	0.14	0.08	0.20	0.08	0.50	0.08	0.40	0.08
	Ss between 0.26 & 0.50	0.20	0.11	0.27	0.11	0.68	0.11	0.54	0.11
	Ss between 0.51 & 1.00	0.25	0.15	0.35	0.15	0.88	0.15	0.70	0.15
	Ss greater than 1.50	0.34	0.20	0.48	0.20	1.20	0.20	0.96	0.20
	Ss greater than 1.50	0.57	0.33	0.80	0.33	0.33	0.33	1.60	0.33

S.S Values for Pakistan

- Islamabad-1.68
- Karachi-1.65
- Lahore-0.62
- Peshawar-1.65



SPECIFICATIONS

PROJECT NO : 1890
PROJECT TITLE : SSGCL HEAD OFFICE BUILDING, KARACHI
DATED : 20TH APRIL, 2026

3. Seismic Certification and Analysis

- a. Seismic restraint calculations must be provided for all connections of equipment to the structure. Calculations must be stamped by a registered professional engineer with at least five years of seismic design experience.
- b. All restraining devices shall have a preapproval number from California OSHPD or some other recognized government agency showing maximum restraint ratings. Preapprovals based on independent testing are preferred to preapprovals based on calculations. Where preapproved devices are not available, submittals based on independent testing are preferred. Calculations (including the combining of tensile and shear loadings) to support seismic restraint designs must be stamped by a registered professional engineer with at least five years of seismic design experience. Testing and calculations must include both shear and tensile loads as well as one test or analysis at 45° to the weakest mode.
- c. Analysis must indicate calculated dead loads, static seismic loads and capacity of materials utilized for connections to equipment and structure. Analysis must detail anchoring methods, bolt diameter, embedment and/or welded length. All seismic restraint devices shall be designed to accept, without failure, the forces detailed in section 1.06 acting through the equipment centre of gravity. Overturning moments may exceed forces at ground level.

1.03 Code and Standards Requirements:

A. Typical Applicable codes and Standards

1. To the specifying engineer: Please see section 1.03 Code and Standards Requirements in the instruction Manual for applicable codes. You will be referencing 1 or more codes in 1.03A depending on geographical location. The maps on pages 6 & 7 may be of value to you.

1.04 Manufacturer's Responsibility:

- A. Manufacturer of vibration isolation and seismic control equipment shall have the following responsibilities:
 1. Determine vibration isolation and seismic restraint sizes and locations.
 2. Provide vibration isolation and seismic restraints as scheduled or specified.
 3. Provide calculations and materials if required for restraint of un-isolated equipment.
 4. Provide installation instructions, drawings and trained field supervision to insure proper installation and performance.

1.05 Related Work:

A. Housekeeping Pads

1. Housekeeping pad reinforcement and monolithic pad attachment to the structure details and design shall be prepared by the restraint vendor if not already indicated on the drawings.
2. Housekeeping pads shall be coordinated with restraint vendor and sized to provide a minimum edge distance of ten (10) bolt diameters all around the outermost anchor bolt to allow development of full drill-in wedge anchor ratings. If cast-in anchors are to be used, the housekeeping pads shall be sized to accommodate the ACI requirements for bolt coverage and embedment.

B. Supplementary Support Steel

1. Contractor shall supply supplementary support steel for all equipment, piping, ductwork, etc. including roof mounted equipment, as required or specified.



SPECIFICATIONS

PROJECT NO : 1890
PROJECT TITLE : SSGCL HEAD OFFICE BUILDING, KARACHI
DATED : 20TH APRIL, 2026

C. Definitions

1. Life Safety Systems

- a. All systems involved with fire protection including sprinkler piping, fire pumps, jockey pumps, fire pump control panels, service water supply piping, water tanks, fire dampers and smoke exhaust systems.
- b. All systems involved with and/or connected to emergency power supply including all generators transfer switches, transformers and all flowpaths to fire protection and/or emergency lighting systems.
- c. All medical and life support systems.
- d. Fresh air relief systems on emergency control sequence including air handlers, conduit, duct, dampers, etc.

2. Positive Attachment

- a. A positive attachment is defined as a cast-in anchor, a drill-in wedge anchor, a double sided beam clamp loaded perpendicular to a beam, or a welded or bolted connection to structure. Single sided "C" type beam clamps for support rods of overhead piping, ductwork, fire protection, electrical conduit, bus duct, or cable trays, or any other equipment are not acceptable on this project as seismic anchor points.

3. Transverse Bracing

- a. Restraint(s) applied to limit motion perpendicular to the centreline of the pipe, duct or conduit.

4. Longitudinal Bracing

- a. Restraint(s) applied to limit motion parallel to the centreline of the pipe, duct or conduit.

1.02 Submittal Data Requirements:

- A. The manufacturer of vibration isolation and seismic restraints shall provide submittals for products as follows:

1. Descriptive Data

- a. Catalogue cuts or data sheet on vibration isolators and specific restraints detailing compliance with the specification.
- b. Detailed schedules of flexible and rigidly mounted equipment, showing vibration isolators and seismic restraints by referencing numbered descriptive drawings.

2. Shop Drawings

- a. Submit fabrication details for equipment bases including dimensions, structural member sizes and support point locations.
- b. Provide all details of suspension and support for ceiling hung equipment.
- c. Where walls, floors, slabs or supplementary steel work are used for seismic restraint locations, details of acceptable attachment methods for ducts, conduit and pipe must be included and approved before the condition is accepted for installation. Restraint manufacturers' submittals must include spacing, static loads and seismic loads at all attachment and support points.
- d. Provide specific details of seismic restraints and anchors; include number, size and locations for each piece of equipment.

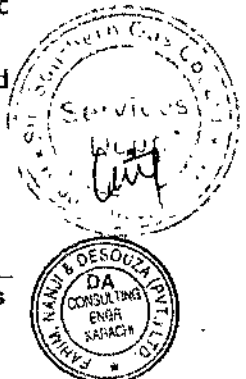
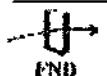

SPECIFICATIONS

PROJECT NO : 1890
PROJECT TITLE : SSGCL HEAD OFFICE BUILDING, KARACHI
DATED : 20TH APRIL, 2026

SEISMIC RESTRAINTS

PART 1 - GENERAL

1.01 Description:

A. Intent

1. All mechanical equipment, piping and ductwork as noted on the Equipment Data Sheet or in the specification shall be mounted on vibration isolators to prevent the transmission of vibration and mechanically transmitted sound to the building structure. Vibration isolators shall be selected in accordance with the weight distribution so as to produce reasonably uniform deflections.
2. All isolators and isolation materials shall be of the same manufacturer and shall be certified by the manufacturer.
3. It is the intent of the seismic portion of this specification to keep all mechanical and electrical building system components in place during a seismic event.
4. All such systems must be installed in strict accordance with seismic codes, component manufacturer's and building construction standards. Whenever a conflict occurs between the manufacturers or construction standards, the most stringent shall apply.
5. This specification is considered to be minimum requirements for seismic consideration and is not intended as a substitute for legislated, more stringent, national, state or local construction requirements.
6. Any variance or non-compliance with these specification requirements shall be corrected by the contractor in an approved manner.
7. Seismic restraints shall be designed in accordance with seismic force levels as detailed in section 1.06.

B. The work in this section includes, but is not limited to the following:

1. Vibration isolation for piping, ductwork and equipment.
2. Equipment isolation bases
3. Flexible piping connections
4. Seismic restraints for isolated equipment
5. Seismic restraints for non-isolated equipment.
6. Certification of seismic restraint designs and installation supervision
7. Certification of seismic attachment of housekeeping pads
8. All mechanical and electrical systems. Equipment buried underground is excluded but entry of services through the foundation wall is included. Equipment referred to below is typical. (Equipment not listed is still included in this specification).

AC Units	Chillers	Fans (All Types)	Tanks (All Type)
Air Distrib. Boxes	Compressors	Generators	Transformers
Air Handling Units	Comp. Room Units	Heat Exchangers	Unit Heaters
Air Separators	Condensers	Light Fixtures	Unit Substations
Battery Racks	Condensing Units	Motor Control Ctrs.	Var. Freq. Drives
Boilers	Conduit	Piping	Water Heaters
Bus Ducts	Cooling Towers	Pumps (All types)	-
Cabinet Heaters	Ductwork	Rooftop Units	-
Cable Trays	Electrical Panels	Switching Gear	-



SPECIFICATIONS

PROJECT NO : 1890
PROJECT TITLE : SSGCL HEAD OFFICE BUILDING, KARACHI
DATED : 20TH APRIL, 2026

- f) Isolated drains shall consist of a two member housings designed to be cast into floating slab and structural slab with no rigid contact between the two members.

PART-3: EXECUTION

3.1 Installation:

A. For Floating Floor

1. Ensure all areas to receive sound isolation are dry, and cleared of debris.
2. Set and adhere perimeter isolating boards to all curbs and penetrations.
3. Roll out isolation material with mounts and acoustical blanket attached in accordance with manufacturer's drawings and installation instructions. Insert additional mounts for high load area as detailed in drawings.
4. Lay plywood pouring form sheets on top of isolation mounts, staggering joints, and connect edges using junction plates and screws as per manufacturer's recommendations.
5. Install two layers of polyethylene sheet over entire floor area, extending up and over perimeter isolation. Seams shall be overlapped 4" and continuously taped to prevent against concrete leakage.
6. Install reinforcing and pour floating slab.
7. After concrete has cured, remove filler strip from perimeter and caulk all joints with perimeter sealant.

3.2 Field Quality Control:

A. For Floating Floors

Notification shall be given by the Contractor to the Architect, Engineer and field representative of the isolation material manufacturer to inspect the installation at the following stages:

1. Upon completion of all areas prior to the placement of the isolation materials. All surfaces shall receive Engineers approval before installation of isolation materials.
2. Upon completion of placement of isolation material prior to placement of form-work. The manufacturer's representative shall be on hand to assist in the initial stages of placement of isolation material to insure the proper procedures and techniques are strictly followed.
3. Upon completion of the finished floor and installation of sealant. The final inspection of the isolation system shall be made at this time. Any evidence of faulty performance shall be evaluated and such imperfections shall be corrected at no cost to the Owner.

END OF SECTION 23 05 48

SPECIFICATIONS

PROJECT NO : 1890
PROJECT TITLE : SSGCL HEAD OFFICE BUILDING, KARACHI
DATED : 20TH APRIL, 2026

2. Curb Mounted Base:

Curb isolation systems shall have spring isolation with a watertight and airtight curb assembly. The roof curbs must accommodate the small diameter of the springs within the rails, with static deflection in the 1 to 3 in. range.

3. Structural Base:

Structural bases shall be used where equipment cannot be supported at individual locations and/or where some means is necessary to maintain alignment of component parts in equipment. These bases can be used with spring or rubber isolators and should have enough rigidity to resist all starting and operating forces without supplemental hold-down devices. Bases are made in rectangular configurations using structural members with a depth equal to one-tenth the longest span between isolators, with a minimum depth of 4 in. maximum depth is limited 12 in. unless specified.

4. Structural Rails:

Structural rails shall be used to support equipment that does not require a unitary base or where the isolators are outside the equipment and the rails act as cradle. Structural rails can be used with spring or rubber isolators and should be rigid enough to support the equipment without fixing. Use structural members with a depth one-tenth of the longest span between isolators with a minimum depth of 4 in. maximum depth is limited to 12 in. unless otherwise specified.

E. Floating Floors

1. General:

- a) The extent of the sound isolation floor is shown on the drawings.
- b) Concrete, reinforcement and water-proofing shall conform to specifications given for civil works.
- c) The floating floor shall be completely isolated from the building structure by resilient isolation mounting supporting the floating floor, and by resilient perimeter isolation material at all adjoining curbs. All penetrations e.g. piping, ductwork, drains shall be isolated from the floating floor so that no rigid contact exists between floating floor and structure.
- d) All sound isolation materials shall be provided by a single manufacturer to assure single responsibility for proper performance.
- e) Installation of materials is to be done by workmen familiar with this type of work.

2. Materials:

- a) Pre-compressed glass fibre isolation materials shall consist of 2" high isolation mounts bonded to a 1½" thick low density fibreglass noise absorption blanket. Mount spacing and location shall be as per manufacturer's recommendation and drawings.
- b) Perimeter isolating boards shall be ¾" thick, closed cell neoprene/expanded polyethylene.
- c) Perimeter sealant shall be non-hardening, non-drying, and non-bleeding rubber based sealant.
- d) Plywood pouring forms shall be minimum ½" thick exterior grade attached using metal junction plates.
- e) Polyethylene sheeting for bond breaker and temporary water proofing shall be of 6 mil thickness.



SPECIFICATIONS

PROJECT NO : 1890
PROJECT TITLE : SSGCL HEAD OFFICE BUILDING, KARACHI
DATED : 20TH APRIL, 2026

both sides of the fabric. Fabric shall be a heavy glass fibre fabric coated with neoprene.

C. Vibration Isolators

1. Rubber Pads or Mounts: Rubber isolators shall be either pad type or molded mount type. Material of molded isolators shall be in the range of 30-70 durometer. Isolators shall be designed for up to 0.5 in. deflection, but used where 0.3 in. or less deflection is required. Solid rubber and composite fabric and rubber pads shall be used as noise barriers under columns and for pipe supports where shown on drawing or where needed. Metal loading plates shall be used for even distribution of load on the pad surface.
2. Pre-Compressed glass fibre isolation pads: Glass fiber pads shall be used for the isolation of concrete foundations and floating floor construction or for application where shown. Pre-compressed glass fiber isolation pads shall be of inorganic inert material and shall be available in thickness of 1 to 4 in. and in capacities of up to 500 psi. The manufacturing process shall assure long life and a constant natural frequency of 7 to 15 Hz over the entire load range. Pads shall be covered with an elasto-meric coating to increase damping and to protect the glass fiber.

3. Spring Isolators:

All spring isolators shall have a rubber acoustical barrier to reduce transmission of high-frequency vibration and noise that can migrate down the steel spring coil. They should be corrosion-protected if installed outdoors or in a corrosive environment.

- Open spring isolators shall consist of a top and bottom load plate with an adjustment bolt for levelling. Springs shall be designed with a horizontal stiffness at least 100% of the vertical stiffness to assure stability, 50% travel beyond rated load and safe solid stresses.
- Restrained spring isolators shall have hold-down bolts to limit vertical movement. Spring criteria shall be the same as for open spring isolators, and restraints shall have adequate clearance so that they are activated only when a temporary restraint is needed.
- All Boilers, chillers and cooling towers shall be provided with Restrained Spring Isolators.

4. Air Springs:

For applications where the resulting deflection with spring type isolators is more than 6 inch and/or where natural frequency of equipment is 1.33 Hz or below, air springs shall be used to replace high deflection springs with the approval of the Engineer.

5. Isolation Hangers:

Isolation Hangers shall be used for suspended pipe and equipment and shall have rubber, springs, or a combination of spring and rubber elements. Criteria should be the same as for open spring isolators. Swivel or traveller arrangements may be necessary for connections to piping systems subject to large thermal movements.

D. Vibration Isolated Bases

1. Concrete Base/Inertia Base:

Concrete bases shall consist of a steel pouring form with welded-in reinforcing bars, provision for equipment hold-down, and isolator brackets. It shall have a depth equal to one-tenth the longest span between isolators, with a minimum of 6 in. Base depth shall not exceed 12 in. unless specified.

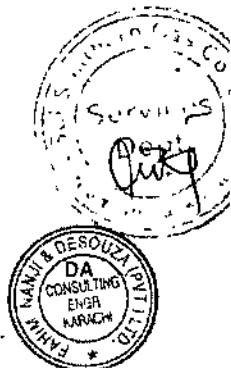

SPECIFICATIONS

PROJECT NO : 1890
PROJECT TITLE : SSGCL HEAD OFFICE BUILDING, KARACHI
DATED : 20TH APRIL, 2026

VIBRATION ISOLATION AND CONTROL

PART-1: GENERAL

1.1 Performance Requirements:

- A. The Contractor shall install vibration isolation and control products as specified herein and ensure that unacceptable vibration is not transferred to the building structure.

1.2 Submittals:

A. Tendering Stage Submittal

The tenderer shall indicate the vibration isolation device he intends to use and shall provide their source.

B. Construction Stage Submittal

The contractor shall provide complete details of all vibration control devices to be used, and shall obtain Engineer approval.

1.3 Quality Assurance:

- A. During installation & during operation checking shall be carried out to ensure that vibration isolation products are performing as desired.

1.4 Warranty:

- A. Manufacturer shall guarantee the equipment and components against defects in materials and/or workmanship for a period of one year from date of initial operation or 18 months from date of shipment, whichever occurs first, unless otherwise stated elsewhere in this document.

PART-2: PRODUCTS

2.1 Equipment:

A. Flexible Connectors for Pipelines

Flexible connectors shall be constructed of rubber, tetrafluoroethylene resin, or corrosion resisting steel, bronze, monel or galvanised steel. The material used and the configuration shall be suitable for pressure, vacuum, temperature and circulation medium. The flexible sections may have threaded, welding, soldering, flanged or socket ends and shall be suitable for service intended. The flexible section may be reinforced with metal retaining rings, with built in reinforcement and restriction bolts or with wire braid cover suitable for the service intended. Flanged assemblies shall be equipped with limit bolts to restrict maximum travel within limits standard with the manufacturer. Unless otherwise shown on the drawings, the length of the flexible connector shall be as recommended by the manufacturer for the service intended. Internal sleeves or liners shall be provided when recommended by the manufacturer suitable for the circulating medium. Covers to protect the bellows will be provided where necessary or directed. Flexible connectors shall be designed for a minimum of 125 Psi (8.5 bars) service, and 250°F (120°C), or higher as required.

Flexible pipe connectors shall be installed on piping connected to equipment where indicated on the drawings. Installation shall be in accordance with manufacturer's recommendations.

B. Flexible Duct Connectors for Air-Moving Equipment

All air ducts attached to a fan, air handling unit or other mechanical equipment shall be provided with an air-tight flexible joint to isolate the vibration & noise.

This shall consist of an air-tight flexible fabric mechanically intertwined into sheet metal seams at its two edges to provide a 3 inch fabric and 3 inch metal connector on



SPECIFICATIONS

PROJECT NO : 1890
PROJECT TITLE : SSGCL HEAD OFFICE BUILDING, KARACHI
DATED : 20TH APRIL, 2026

3.4 Reference Specification:

- A. The following specifications shall be construed to be part of these specifications.
1. 23 05 01 - Basic Mechanical Requirement
 2. 23 05 02 - Basic Mechanical Materials and Methods

END OF SECTION 23 05 29



SPECIFICATIONS

PROJECT NO : 1890
PROJECT TITLE : SSGCL HEAD OFFICE BUILDING, KARACHI
DATED : 20TH APRIL, 2026

DUCT WORKS & ACCESSORIES

1. Sheet Metal:

Sheet metal duct work shall be constructed of galvanised sheet steel conforming to ASTM A653, lock-forming quality, uncoiled, regular spangle and having a minimum coating of 275 g/m².

2. Duct Construction and Installation Standards:

- a) All duct construction and installation shall be carried out in accordance with current SMACNA HVAC Duct Construction Standards and SMACNA Accepted Industry Practice for Industrial Duct Construction, unless otherwise indicated herein.
- b) Each duct system shall be constructed for the specific duct pressure requirements of the project as per the external static pressure.
 - 1" WG pressure class shall be the minimum basis of compliance with the standards, regardless of the velocity in the duct, except when the system is variable volume. Measurement of duct velocity to be entirely the responsibility of the Contractor.
 - All variable volume duct up-stream of VAV boxes shall have a 2" minimum basis of compliance. Measurement of duct velocity to be entirely the responsibility of the Contractor.
 - 2" WG pressure class shall be the minimum basis of compliance for all ducts having velocity greater than 2000fpm and less than or equal to 2500fpm. Measurement of duct velocity to be entirely the responsibility of the Contractor.
 - 3" WG pressure class shall be the minimum basis of compliance for all ducts having velocity greater than 2500fpm and less than or equal to 4000fpm. Measurement of duct velocity to be entirely the responsibility of the Contractor.
- c) Minimum sheet thickness to be used shall be as follows, unless static pressure requirements dictate higher thickness as per SMACNA standards see TABLE-3 & 4 on pages 23 31 13-7 & 23 31 13-8 respectively.

Table-1A: (Applicable for Duct Velocities ≤ 2000fpm)

Largest Dimension of Ducting Inches (mm)	U.S.S. Gauge	Minimum Nominal Thickness Inches (mm)
Upto 27" (675mm)	24	0.028 (0.70)
28" - 51" (700mm-1275mm)	22	0.034 (0.86)
52" - 81" (1300mm-2000mm)	20	0.04 (1.02)
Above 81" (2025mm)	18	0.052 (1.32)

In the event U.S.S gauge sheets are not available, the minimum nominal thickness indicated shall be followed.

Table-1B: (Applicable for Duct Velocities > 2000fpm & ≤ 4000fpm)

Largest Dimension of Ducting Inches (mm)	U.S.S. Gauge	Minimum Nominal Thickness Inches (mm)
Upto 12" (300mm)	22	0.034 (0.86)
13" - 40" (325mm-1000mm)	22	0.034 (0.86)
41" - 60" (1025mm-1500mm)	20	0.04 (1.02)
61" - 90" (1525mm-2250mm)	18	0.052 (1.32)

- d) Ducts shall be sealed in accordance with TABLE-2 below:



SPECIFICATIONS

PROJECT NO : 1890
PROJECT TITLE : SSGCL HEAD OFFICE BUILDING, KARACHI
DATED : 20TH APRIL, 2026

Table-2: Duct Sealing Requirements

Seal Class	Sealing Required	Static Pressure Construction Class
A	All transverse joints, longitudinal seams and duct wall penetrations	4" w.g. and up
B	All transverse joints and longitudinal seams	3" w.g.
C	Transverse joints	2" w.g.
	In addition to the above any variable air volume system duct of 1" and ½" w.g construction class that is upstream of the VAV boxes shall also meet Seal Class C.	

- e) Unless otherwise specified or allowed rectangular ductwork shall be constructed in accordance with TABLE-3 to 6 herein.
- f) Unless otherwise specified, reinforcement shall be galvanised steel.
- g) Duct sides that are 19" and over and are 20 gauge or less with more than 10 sq.ft. of unbraced panel area shall be beaded.
- h) Fittings shall be reinforced similarly to sections of straight duct. On size change fittings the greater fitting dimension determines the duct gauge.
- i) For ducts 97 inches & above, tie rods shall be provided to provide internal support to ducts. The tie-rod shall be located at equal sub-divisions of width, but spacing shall not exceed 60 inches.
- j) Tie rod shall be galvanised steel of ¾" inch (10mm) minimum diameter.
- k) Transverse joints shall be selected and used consistent with the static pressure class, applicable sealing requirements, materials involved, duct support intervals and other provisions for proper assembly of duct work outlined in the SMACNA Standards.
- l) Where bar or angle stock is incorporated in a joint it shall be secured with a fastener. Fastener shall be steel if used on a steel duct & shall be zinc or cadmium coated.
- m) Longitudinal Seams shall be suitably selected for the material, pressure classification and other construction details applicable for the service as recommended in the SMACNA Standards.
- n) Installation Standards for rectangular ducts using flexible liner.
- o) Unless otherwise indicated, the net free area of the duct dimension given in the contract drawings shall be maintained. The duct dimensions shall be increased as necessary to compensate for liner thickness.
- p) Unless otherwise approved ducts shall conform accurately to the dimensions indicated and shall be straight and smooth on the inside, with joints neatly finished. Ducts shall be secured to the structural slab in the building, and the method of anchoring and/or fastening shall be as detailed on the drawings. Ducts shall be constructed and installed so as to be completely free from all vibrations under all conditions of operation. Layout drawings required under the clause APPROVAL OF MATERIALS AND EQUIPMENT shall show, for suspended duct work, the location of all supports, typical details for anchorages, and details for special anchorages.
- q) Curved elbows shall have a centreline radius not less than 1.5 times the width or diameter of the duct.
- r) Transformations shall be made with sides pitched not to exceed a maximum of 20° or 40° included angle, for diverging air flow and 30°, or 60° included angle, for converging air flow, or as indicated on the drawings.



SPECIFICATIONS

PROJECT NO : 1890
PROJECT TITLE : SSGCL HEAD OFFICE BUILDING, KARACHI
DATED : 20TH APRIL, 2026

- s) Splitter dampers, quadrant volume dampers, air deflectors, fire doors and fire dampers, duct access doors and duct test holes shall be installed where shown on the drawings and where required for the proper operation of the system even though not shown on the drawings.
- t) Other details for duct construction, casing construction, access doors, hangers and supports, duct joints, volume damper, penetration of casing, casing curb detail, hood construction etc., shall be as indicated on the drawings or as per SMACNA Duct Construction Standards, or as directed by the Engineer. All connections of ducting to air handling units, dampers, plenums, etc., shall be through removable flanges. Installation of items not shown in detail or not covered by detailed specifications shall be as set forth in the SMACNA Construction Standards.
- u) Ducts passing through walls shall be provided with 20 gauge GI Sheet sleeve covering the full width of wall, and fabricated with necessary edges and stiffness.
- v) All joints shall be sealed with an approval duct sealant such as Silicon Sealant or approved equivalent. Putty shall not be used.

3. Round Duct Construction Standards:

- a) Round ducts shall be constructed in accordance with TABLE-5.
- b) Fittings shall be wall thickness not less than that specified for longitudinal seams straight ducts.
- c) For round ducts with static pressure between 4 to 7 inches, maximum reinforcing shall be at 96 inches distance.
- d) Where other limitations are not provided, mitred elbows shall be based on velocity of flow and shall be constructed to apply with following TABLE-6.

Table-5: Round Duct Gauge Selection Galvanised Steel

Duct Diameter In Inches	Maximum 2" w.g Static Positive		Maximum 10" w.g Static Positive		Maximum 2" w.g Static Negative	
	Spiral Seam Gauge	Longitudi- nal Seam Gauge	Spiral Seam Gauge	Longitudi- nal Seam Gauge	Spiral Seam Gauge	Longitudi- nal Seam Gauge
3 through 8	28	28	26	24	28	24
9 through 14	28	26	26	24	26	24
15 through 26	26	24	24	22	24	22
27 through 36	24	22	22	20	22	20
37 through 50	22	20	20	20	20	18
51 through 60	20	18	18	18	18	16
61 through 84	18	16	18	16	16	14

Table-6: Mitred Elbows

Duct Velocity	R/D Ratio Centreline Radius to Duct Diameter	Number of Mitred Pieces		
		90°	60°	45°
Upto 1000 fpm	0.6	3	2	2
1001 to 1500 fpm	1.0	4	3	2
Above 1500 fpm	1.5	5	4	3

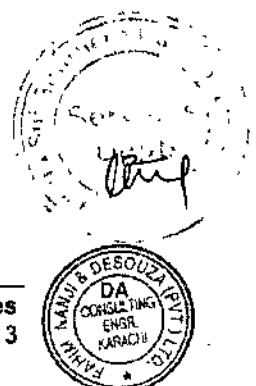

SPECIFICATIONS

PROJECT NO : 1890
PROJECT TITLE : SSGCL HEAD OFFICE BUILDING, KARACHI
DATED : 20TH APRIL, 2026

4. Hanging & Supporting System:

Rigid round, rectangular metal ducts shall be installed with support systems indicated in TABLE-7&8 given below, and additionally as required to maintain alignment. Horizontal ducts shall have a support within 2 feet of each elbow and within 4ft of each branch intersection.

Table-7: Rectangular Duct Hangers Minimum Size

Maximum Half of Duct Perimeter (Inches)	Rod Dia Pair (Inches)	Maximum Spacing (Ft.)
30	3/8"	10'
72	3/8"	8'
96	3/8"	8'
120	3/8"	8'
168	3/8"	5'
192	3/8"	4'
193 & UP	Special Analysis Required as Approved by Engineer.	

Table-8: Minimum Hanger Sizes for Round Duct

Dia	Maximum Spacing	Rod
10" dn.	12'	¼"
11-18"	10'	3/8"
19-24"	10'	3/8"
25-36"	10'	3/8"
37-50"	10'	Two 3/8"
51-60"	10'	Two 3/8"
61-84"	08'	Two 3/8"

5. Duct Leakage Test:

Ducts, Plenums and casings shall be tested and made substantially air tight at static pressure indicated for the system before covering with insulation or concealing in the masonry. The term substantially air tight shall be construed to mean that no air leakage is noticeable through the senses of feeling or hearing.

For Low Pressure System, up to 2" w.g. (500 Pa), all joints shall be sealed with sealant and physically inspected for light penetration from outside to inside. For system operating pressure above 2 inches of Wg. (500 Pa), smoke test will be performed by connecting a fan to the duct system to build up the operating pressure, and checking for leakage at all joints, which shall then be sealed with silicone sealant and the system retested.

All ducting and related airside equipment and accessories for low grain application (40 grains-14 grains) must be fully sealed with silicone sealant only and made fully air-tight.

6. Galvanising:

All hangers, angle iron bracing & other iron work shall be hot dip galvanised. Cut surfaces shall be painted with two coats of primer paint.



SPECIFICATIONS

PROJECT NO : 1890
PROJECT TITLE : SSGCL HEAD OFFICE BUILDING, KARACHI
DATED : 20TH APRIL, 2026

7. Ductwork Accessories:

- a) **General:** Following ductwork accessories shall be installed where specified and shown on drawings. All accessories shall be constructed of galvanised iron sheet metal conforming to specifications given.
- b) **Splitter Damper:** Shall be fabricated of sheet metal, two gauges heavier than the duct gauge in which the damper is installed. Damper shall be fabricated of wood of an aerofoil shape, over which sheet metal shall be formed to completely cover the wood. Damper shall be operated by a 10mm dia rod brought through the side of the duct with brass locking set-screw and bushing. Two operators shall be required on splitters over 8"(200mm) wide. For insulated ducts, bushing shall be of thickness equal to the thickness of the duct insulation. Locking set screw shall be $\varnothing \frac{1}{4}$ " (6mm), arranged for easy locking of the damper operator at the desired position. Damper shall be installed with full length hinge. Rubber gaskets shall be installed to minimise air leakage. Damper operator shall be galvanised and shall be designed for convenience of operation.
- c) **Quadrant Volume Damper:** shall be multi-leaf opposed blade type, with a maximum blade width of 8" (200mm) operated by a train of gears installed within the damper casing with the gears protected against direct impingement of the air stream. Dampers shall be constructed of galvanised sheet metal, machine formed of aerofoil design to provide tight shut-off & low leakage. Leakage data at various pressure differentials shall be submitted. They shall be operated by quadrant operators manufactured of brass. Bushing shall be of brass, nylon or hard acetal. Operators shall be provided with stand-off mountings on thermally insulated ducts to provide clearance between the ducts surface and operator, equal to the thickness of the insulation. Quadrant operator shall be heavy duty, capable of being locked at desired position conveniently. The casing width shall be larger than the full open width length of the blades. Damper shall be provided with flanges for duct connection.

Dampers for smoke control application shall be heavy ducting with material selected to with stand fire exposure as per NFPA recommendations.

- d) **Air Deflectors:** shall be provided in all square elbows, duct mounted supply outlets, take-off or extension collars to supply outlets and tap-in-branch take-off connections. Air deflectors will be factory-fabricated units consisting of curved turning vanes or louver blades for uniform air distribution and change of direction with minimum turbulence and pressure loss. Square elbows shall be provided with curved vanes.
- e) **Duct Access Doors:** Hinged access doors shall be provided at all volume control dampers, splitter dampers, automatic dampers, fire dampers, coils, thermostats, plenums, filters and other apparatus requiring services and inspection in the duct system. Doors shall be 15" to 18" (380 to 450mm) wide unless otherwise required. Where size of duct will not accommodate this size, the doors shall be made as large as practical. Doors shall be rigid and provided with airtight rubber gaskets. Doors shall be provided with galvanised hinges with bronze pins and two approved brass fasteners. Doors 24 by 24 inches 600mm by 600mm or larger shall be provided with fasteners operable from both sides. Doors in insulated ducts shall be of the insulated type, with the insulation fully enclosed between sheet metal unless otherwise indicated, doors shall so swing that fan pressure or suction holds the door closed.
- f) **Duct Test Holes:** At suitable points throughout the duct work system including mains and all branches, where the air flow is stable, duct test holes shall be in-stalled suitable for pitot tube insertion. On each duct test hole shall be installed a "Duct Test Hole Attachment" consisting of a die-formed attachment & provided with a rubber sealing cap with hand screw tightening arrangement.
- g) **Fire Dampers:** shall be provided where shown on drawings & shall be similar to model FK as manufactured by TROX. Fire doors and fire dampers shall be automatic operating



SPECIFICATIONS

PROJECT NO : 1890
PROJECT TITLE : SSGCL HEAD OFFICE BUILDING, KARACHI
DATED : 20TH APRIL, 2026

type approved for the protection of openings in one, two and four hour fire-rated walls and partitions and shall be installed in accordance with the Engineer's directives. Suitable hand-hole openings with tightly fitted access covers or doors shall be provided in the fire dampers to make all fire doors and fire dampers accessible for inspection and maintenance. Unless otherwise shown, the installation details given in SMACNA Fire Damper Guide for fire dampers shall be followed except minimum thickness of metal for all sleeves provided for the fire dampers shall be not lighter than 14 gauge (1.90mm). All necessary items associated with the fire doors and fire dampers such as retaining angles, sleeves, breakaway connections and access doors shall be provided. The fire dampers shall have a mechanism to show the open-closed status of the fire dampers by means of an indicating lever visible below the false ceiling.

Materials shall be as follows:

- ◆ Casing..... steel, minimum 12 gages
- ◆ Blade Steel, minimum 12 gages
- ◆ Fusible Link..... to operate at 72°C
- ◆ Bushes Stainless Steel

8. Reference Specification:

The following specifications shall be construed to be part of these specifications. ▀

- 23 05 01 – Basic Mechanical Requirement
- 23 05 02 – Basic Mechanical Materials and Methods
- 23 05 10 – Equipment Installation
- 23 05 29 – Supports & Anchors
- 23 05 48 – Vibration Isolation Control
- 23 05 50 – Painting & Coating
- 23 05 53 – Mechanical Identification



SPECIFICATIONS

PROJECT NO : 1890
PROJECT TITLE : SSGCL HEAD OFFICE BUILDING, KARACHI
DATED : 20TH APRIL, 2026

TABLE 3 – RECTANGULAR DUCT THICKNESS & REINFORCEMENT

STATIC PRESSURE	1" WG	2" WG	3" WG	4" WG	6" WG
GREATER DUCT DIMENSION IN INCHES	MINIMUM RIGIDITY CLASS, THICKNESS & REINFORCEMENT	MINIMUM RIGIDITY CLASS, THICKNESS & REINFORCEMENT	MINIMUM RIGIDITY CLASS, THICKNESS & REINFORCEMENT	MINIMUM RIGIDITY CLASS, THICKNESS & REINFORCEMENT	MINIMUM RIGIDITY CLASS, THICKNESS & REINFORCEMENT
24 US SHEET METAL GAUGE					
10 & BELOW	NO REINFORCEMENT	NO REINFORCEMENT	NO REINFORCEMENT	NO REINFORCEMENT	A 3/4"x1/8" ⊕ 5' C/C MAX
11, 12	↓	A 3/4"x1/8" ⊕ 8' C/C MAX	A 3/4"x1/8" ⊕ 5' C/C MAX	A 3/4"x1/8" ⊕ 5' C/C MAX	↓
13, 14	A 3/4"x1/8" ⊕ 10' C/C MAX	↓	↓	↓	A 3/4"x1/8" ⊕ 10' C/C MAX
15, 16	↓	↓	↓	↓	↓
17, 18	↓	↓	↓	↓	B 3/4"x1/8" ⊕ 4' C/C MAX
19, 20	↓	B 3/4"x1/8" ⊕ 6' C/C MAX	↓	B 3/4"x1/8" ⊕ 4' C/C MAX	↓
21, 22	A 3/4"x1/8" ⊕ 8' C/C MAX	↓	B 3/4"x1/8" ⊕ 5' C/C MAX	↓	C 3/4"x1/8" ⊕ 4' C/C MAX
23, 24	↓	↓	↓	C 3/4"x1/8" ⊕ 4' C/C MAX	C 3/4"x1/8" ⊕ 3' C/C MAX
25, 26	↓	↓	C 3/4"x1/8" ⊕ 5' C/C MAX	↓	↓
22 US SHEET METAL GAUGE					
27, 28	C 3/4"x1/8" ⊕ 10' C/C MAX	D 3/4"x1/8" ⊕ 6' C/C MAX	C 3/4"x1/8" ⊕ 5' C/C MAX	D 1"x1/8" ⊕ 5' C/C MAX	B 1"x1/8" ⊕ 4' C/C MAX
29, 30	↓	↓	↓	↓	↓
31-38	D 1"x1/8" ⊕ 8' C/C MAX	D 1"x1/8" ⊕ 5' C/C MAX	D 1"x1/8" ⊕ 4' C/C MAX	E 1 1/2"x1/8" ⊕ 4' C/C MAX	E 1 1/2"x1/8" ⊕ 3' C/C MAX
37-42	D 1"x1/8" ⊕ 6' C/C MAX	↓	↓	E 1 1/2"x1/8" ⊕ 3' C/C MAX	E 1 1/2"x1/8" ⊕ 2 1/2' C/C MAX
43-48	D 1 1/2"x1/8" ⊕ 6' C/C MAX	D 1"x1/8" ⊕ 4' C/C MAX	D 1"x1/8" ⊕ 3' C/C MAX	↓	G 1 1/2"x3/16" ⊕ 2 1/2' C/C MAX
20 US SHEET METAL GAUGE					
49-54	E 1 1/2"x1/8" ⊕ 6' C/C MAX	E 1 1/2"x1/8" ⊕ 4' C/C MAX	G 1 1/2"x3/16" ⊕ 3' C/C MAX	G 1 1/2"x3/16" ⊕ 3' C/C MAX	H 2"x1/8" ⊕ 2 1/2' C/C MAX
55-60	G 1 1/2"x3/16" ⊕ 5' C/C MAX	G 1 1/2"x3/16" ⊕ 4' C/C MAX	↓	H 2"x1/8" ⊕ 3' C/C MAX	↓
61-72	↓	H 2"x1/8" ⊕ 3' C/C MAX	H 2"x1/8" ⊕ 3' C/C MAX	I 2"x3/16" ⊕ 2 1/2' C/C MAX	I 2"x3/16" ⊕ 2' C/C MAX
18 US SHEET METAL GAUGE					
73-84	I 2"x3/16" ⊕ 5' C/C MAX	E 1 1/2"x1/8" ⊕ 4' C/C MAX	J 2 1/2"x1/8" ⊕ 5' C/C MAX	J 2 1/2"x1/8" ⊕ 2 1/2' C/C MAX	K 2 1/2"x3/16" ⊕ 2' C/C MAX
85-96	I 2"x3/16" ⊕ 4' C/C MAX	G 1 1/2"x3/16" ⊕ 3' C/C MAX	K 1 1/2"x3/16" ⊕ 2 1/2' C/C MAX	K 2 1/2"x3/16" ⊕ 2' C/C MAX	L 2 1/2"x1/4" ⊕ 2' C/C MAX
96-UP	H 2"x1/8" ⊕ 2 1/2' C/C MAX	H 2"x1/8" ⊕ 2 1/2' C/C MAX	H 2"x1/8" ⊕ 2' C/C MAX	L 2 1/2"x1/4" ⊕ 2' C/C MAX	H 2"x1/8" ⊕ 2' C/C MAX

- NOTES:**
1. ALL REINFORCEMENT IS OF EQUAL ANGLE IRON OF SPECIFIED SIZE
 2. TRANSVERSE JOINTS GIVEN IN TABLE-3 ARE TO BE SELECTED ON THE BASIS OF THE FOLLOWING:

Fahim, Nanji & deSouza (Pvt.) Ltd.
 Consulting Engineers

Duct Works & Accessories
 Section 23 31 13-7

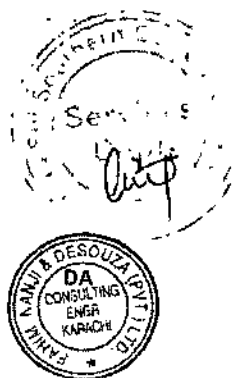

SPECIFICATIONS

PROJECT NO : 1890
PROJECT TITLE : SSGCL HEAD OFFICE BUILDING, KARACHI
DATED : 20TH APRIL, 2026

TABLE 4 - TRANSVERSE JOINT REINFORCEMENT

MINIMUM RIGIDITY CLASS	EI	T-2 STANDING DRIVE-SLIP		T-10 STANDING S		T-11 STANDING S		T-12 STANDING S		T-13 STANDING S		T-14 STANDING S	
		H x T	WT / LF	H x T	WT / LF	H x T	WT / LF	H x T	WT / LF	H x T - HR	WT / LF	H x T - HR	WT / LF
A	0.5	↑		↑		1/2 x 26 ga.	.5	↑		↑			
B	1.0	1 1/8 x 26 ga.	.5	↑		1/2 x 22 ga.	.7						
C	2.5	1 1/8 x 22 ga.	.8	1 x 26 ga.	.6	1 x 26 ga.	.6						
D	5	NOT GIVEN		1 x 24 ga.	.7	1 x 24 ga.	.7	1 1/8 x 26 ga.	.7				
E	10			1 1/8 x 20 ga. w = 3/16"	.9	NOT GIVEN		1 1/8 x 18 ga.	1.4				
F	15			1 5/8 x 22 ga. w = 3/16"	1.0			1 1/2 x 24 ga.	1.0	1 1/2 x 24 ga.	1 1/2 x 1/8 Bar	1.5	
G	25			1 5/8 x 18 ga. w = 3/16"	1.5			1 1/2 x 18 ga.	1.7	1 1/2 x 22 ga.	1 1/2 x 1/8 Bar	1.6	
H	50			NOT GIVEN				NOT GIVEN		1 1/2 x 20 ga.	1 1/2 x 1 1/2 x 3/16	2.9	
I	75									2 x 20 ga.	2 x 2 x 1/8 ga.	2.9	
J	100									2 x 20 ga.	2 x 2 x 3/16	3.7	
K	150									NOT GIVEN			
L	200	↓		↓		↓		↓					

See page 1-15 Nominal EI exact number listed times 10⁴.
 Joints T-2 and T-10 through T-14 are restricted to 30" length at 4" w.g., to 36" length at 3" w.g. and are not recommended for service above 4" w.g.



SPECIFICATIONS

PROJECT NO : 1890
 PROJECT TITLE : SSGCL HEAD OFFICE BUILDING, KARACHI
 DATED : 20TH APRIL, 2026

TABLE 5 - TRANSVERSE JOINT REINFORCEMENT

MINIMUM RIGIDITY CLASS	POCKET LOCK T-17		BAR REINFORCED POCKET LOCK T-18		T-20 CAPPED FLANGE	T-22 COMPANION ANGLES	T-23 FLANGED	T-24 FLANGED			
	MINIMUM	MAXIMUM	MINIMUM	MAXIMUM							
CLASS	EI	H	LOCK T, DUCT T, HR	WT / LF	H x T	U	WT / LF	H x T	WT / LF	H x T	WT / LF
A	0.5		▲					▲		▲	
B	1.0		▲		3/4 x 26 ga.	26 ga.	.4	▲		▲	
C	2.5	T-17 1"	26 ga. Lock on 26 ga.	.6	1 x 24 ga.	24 ga.	.5			1 x 24 ga.	1.0
D	5	T-17 1"	24 ga. Lock, on 24 ga.	.7	1 x 22 ga.	22 ga.	.8			1 x 22 ga.	1.0
E	10	T-18 1"	22 ga. Lock, 1 x 1/8 Bar	1.4	1 1/2 x 24 ga.	22 ga.	.8	TWO 1 x 1/8	1.7	1 x 16 ga. 1 1/2 x 24 ga.	1.0
F	15	T-17 1 1/2"	22 ga. Lock.	1.0	1 1/2 x 20 ga.	20 ga.	1.0	▲		1 1/2 x 22 ga. 1 1/2 x 20 ga.	1.0 1.0
G	25	T-18 1 1/2"	22 ga. Lock, 1 1/2 x 1/8 Bar	1.6	▲	▲		TWO 1 1/4 x 1/8	2.1	1 1/2 x 18 ga.	1.5
H	50	T-19 1 1/2"	20 ga. Lock, 1 1/2 x 3/16 Angle	2.9	2 x 16 ga.	20 ga.	1.5	TWO 1 1/2 x 1/8	2.6	2 x 18 ga.	1.5
I	75	T-19 1 1/2"	20 ga. Lock, 2 x 1/8 Angle	2.8	2 x 16 ga. **			TWO* 1 1/2 x 3/16	3.7	2 x 16 ga.	2.0
J	100	T-19 1 1/2"	20 ga. Lock, 2 x 3/16 Angle	3.5				TWO* 1 1/2 x 1/4	4.7	2" x 18 ga. WITH TIE RODS	
K	150	T-19 1 1/2"	20 ga. Lock, 2 1/2 x 3/16 Angle	4.2				TWO* 2 x 3/16	4.9		
L	200		NOT GIVEN		▼			TWO* 2 x 1/4	6.5	▼	⊗

1 page 115 Nominal EI equals number listed times 10⁶.
 The rod option also Use Class H plus one tie rod. **A tie must be used on each mating flange within 1" of joint center.



SPECIFICATIONS

PROJECT NO : 1890
 PROJECT TITLE : SSGCL HEAD OFFICE BUILDING, KARACHI
 DATED : 20TH APRIL, 2026

TABLE 6 - TRANSVERSE JOINT REINFORCEMENT

MINIMUM RIGIDITY CLASS	T-15 STANDING SEAM		STANDING SEAM OR WELDED FLANGE REINFORCED						T-21 WELDED FLANGE	
	EI	H _S x T	26 TO 22 GA. DUCT			28 TO 16 GA. DUCT			H _S x T	WT/LF
			H _S	H x H x T	WT/LF	H _S	H x H x T	WT/LF		
A	0.5	1/2 x 24 ga.							1/2 x 22 ga.	1
B	1.0	3/4 x 24 ga.						1/2 x 16 ga. 3/4 x 22 ga.	2	
C	2.5	1 x 24 ga.						3/4 x 18 ga. 1 x 22 ga.	3	
D	5	3/4 x 18 ga. 1 x 20 ga.	1"	1 x 1 x 16 ga.	1.0			1 x 18 ga. 1 1/4 x 22 ga.	2 3	
E	10	1 x 16 ga. 1 1/2 x 24 ga.	1"	1 x 1 x 1/8	1.4	1"	1 x 1 x 16 ga.	1.0	1 1/4 x 18 ga. 1 1/2 x 22 ga.	5 4
F	15	1 1/2 x 20 ga.	1 1/2"	1 1/2 x 1 1/2 x 16 ga.	1.8	1 1/2"	1 1/2 x 1 1/2 x 16 ga.	1.7	1 1/4 x 16 ga. 1 1/2 x 20 ga.	6 4
G	25	1 1/2 x 18 ga.	1 1/2"	1 1/2 x 1 1/2 x 1/8 2 x 2 x 16 ga.	2.0	1 1/2"	1 1/2 x 1 1/2 x 1/8	2.4	1 1/2 x 16 ga.	7
H	50	SEE T-16 AND TIE ROD OPTIONS	1 1/2"	2 x 2 x 1/8*	2.7	1 1/2"	1 1/2 x 1 1/2 x 3/16 2 x 2 x 16 ga.	2.8 2.0	SEE T-21a AND TIE ROD OPTIONS	
I	75					1 1/2"	2 x 2 x 1/8*	2.7		
J	100			1 1/2"	2 x 2 x 3/16*	3.5	1 1/2"	2 x 2 x 3/16*	3.5	
K	150			1 1/2"	2 1/2 x 2 1/2 x 3/16*	4.1				
L	200			1 1/2"	2 1/2 x 2 1/2 x 1/4	5.3	1 1/2"	2 1/2 x 2 1/2 x 3/16*	4.1	

See page 1-15. Nominal EI equals number label times 10⁵. *See tie rod option.

END OF SECTION 23 31 13



SPECIFICATIONS

PROJECT NO : 1890
PROJECT TITLE : SSGCL HEAD OFFICE BUILDING, KARACHI
DATED : 20TH APRIL, 2026

PLUG FAN

1. General:

The Contractor shall supply fans of the type specified below, and conforming to the data given in the EQUIPMENT DATA SHEET (Section 2). The Contractor shall be responsible for the proper selection of the fans so that the specified operating conditions are obtained. Motors shall conform to specification under MOTOR (Section 23 05 13) and shall be sized to provide the required BHP for meeting the specified conditions without overloading.

2. Plug Fans:

Shall be direct driven single rotor, Class-I, II or III as required or indicated in the EQUIPMENT DATA SHEET (Section 2) for the design system pressure.

Fan Wheels: shall be rigidly constructed, accurately balanced both statically & dynamically on precision electronic balancers, and shall be free from objectionable noise and vibration.

Each wheel shall be designed for critical speed of at least 1.25 times the maximum class speed. Up to 27 inches fan blades may be forward curved, backward curved or airfoil design. Fan blades over 27 inches shall have backward curved or airfoil design, unless otherwise specified under EQUIPMENT DATA SHEET (Section 2). Forward or backward curved wheel shall be of steel plate, while aerofoil wheels shall be of cast-aluminium, or formed steel with cavity filled.

Fan Shaft: Fans shall have shafts of solid hot rolled steel, accurately turned, ground, polished & ring gauged for accuracy. Close tolerances must be maintained where the shaft makes contact with the bearings. Shaft diameter, must have first critical speed at least 1.35 times the maximum class speed of the fan.

Bearings: Fans shall have heavy duty, grease lubricated, precision anti-friction ball or roller, self-aligning, pillow block type bearings, selected for minimum average bearing life of 125,000 hours when operating at maximum catalogued class conditions. Bearings shall be provided with suitable arrangements for re-lubrication.

Mounting & Drive: The fan and motor drive shall be mounted on heavy steel framing. Drive arrangement shall be as specified, or as recommended by AMCA for the condition of operation. Drive shall be selected for minimum 1.2 BHP.

Painting & Coating: Each fan component shall be thoroughly degreased, phosphatised and provided with two coats of special anti-rust primer and two coats of stove enamelled paint.

3. Installation:

Fans shall be rigidly secured so that they operate without vibration and transmission of vibration to structure shall be isolated. Connection to ducting shall be through flexible connectors. Ducting connection to fan shall ensure lowest turbulence and smooth transition of sides. All supporting arrangement of the fans shall be drawn up by this contractor and submitted to the Engineer for approval.

Floor mounted fan shall be installed as a 100mm high concrete foundation with edges provided with 2x25x3mm angle iron.

4. Commissioning and Testing:

The fans shall be commissioned and tested by this contractor. Test forms, supplied by the Engineers shall be filled in and the Engineer's approval obtained.

5. Reference Specification:

The following specifications shall be construed to be part of these specifications.

- 23 05 01- Basic Mechanical Requirement



SPECIFICATIONS

PROJECT NO : 1890
PROJECT TITLE : SSGCL HEAD OFFICE BUILDING, KARACHI
DATED : 20TH APRIL, 2026

- 23 05 02 – Basic Mechanical Materials and Methods
- 23 05 10 – Equipment Installation
- 23 05 13 – Electric Motors
- 23 05 29 – Supports & Anchors
- 23 05 48 – Vibration Isolation Control
- 23 05 50 – Painting & Coating
- 23 05 53 – Mechanical Identification

END OF SECTION 23 34 17

Handwritten signature



PROJECT NO : 1890
 PROJECT TITLE : SSGCL HEAD OFFICE BUILDING, KARACHI
 DATED : 20TH APRIL, 2026

AIR FILTERS

1. General:

Each air system shall have its own air filters, and shall be of capacities and sizes as given in specifications herein, or in the EQUIPMENT DATA SHEET.

The air-handling unit filter shall be mounted in an air-tight flat or angular filter box of galvanised steel or aluminium sheet so that they can be removed from either end for replacement and cleaning. In an air handling unit the filter section shall be a standard module from the AHU manufacturer.

In selecting the sizes of the air filters, the space available in the Plant Room and air handling units etc., should be kept in view.

The Contractor shall provide the following information for each of the air filters proposed to be supplied by them.

- a) Capacities in CFM and media air velocity.
- b) Initial and Recommended Final air pressure drop in inch of WG (Pa) for each type of filters.
- c) Manufacturer's performance guarantee certificate and technical bulletins.

The Contractor shall install a multi-blade damper in the plenums of air handling unit having high efficiency filters to balance the air system when the filtering media is new with low initial resistance.

2. Viscous Impingement Filters (Filter Class G2 to EN 779):

Filters shall conform to filter Class G2 to CEN Standard EN 779, & provide a Dust Arrestance Efficiency of 65% to 80%.

Filters shall be 2 inch (50mm) thick, permanent viscous impingement, washable, all metal, panel type. Media shall be corrugated strips of aluminium screen enclosed in an 18-gauge aluminium frame with flush mitred corners. The corrugation shall be tapered to form a series of pyramid shaped pockets to prevent dust-laden air from drifting through the filters. Expanded metal shall be placed on both sides of the filtering media to add strength and for mechanical protection.

Resistance to airflow of a clean filter shall not exceed 0.1 inch WG. Pressure drop across the filter and final pressure drop shall not exceed 0.5 inch of WG. The filters shall be selected for face velocities not exceeding 500 fpm (2.5 m/s).

Provide filter adhesive in suitable containers in sufficient quantity for three month's requirement, based on operating the system for 10 hours a day. Provide a filter-washing tank suitable for washing of the particular size of filter.

3. Replaceable Panel Filter (Filter Class G2 to EN 779):

Filters shall conform to filter Class G2 to CEN Standard EN 779, & provide Dust Arrestance Efficiency of 65% to 80%.

This filter shall consist of 2 inch (50mm) thick glass fibre mat coated with dust binding adhesive (Viscosine) as the filtering media. The filtering media shall be fixed into a U-shaped metal frame and a metal grid shall be provided for additional support.

The filter shall be supplied with a 50mm deep galvanised steel cell (holding) frame with quick release clamps or hinge type spring clips for positive airtight clamping of the filter.

The filter shall have a rated face velocity of 500 FPM (2.5 m/s) with maximum initial resistance of 0.24 inch of WG (60 Pa) and final pressure drop of 0.72 inch of WG (180 Pa).



SPECIFICATIONS

PROJECT NO : 1890
PROJECT TITLE : SSGCL HEAD OFFICE BUILDING, KARACHI
DATED : 20TH APRIL, 2026

4. Throwaway Disposable Synthetic Media Panel Filters (Filter Class G4 to EN 779):

Filters shall conform to filter Class G4 to CEN Standard EN 779, & provide Dust Arrestance Efficiency of greater than 90%.

This filter shall be a pleated disposable filter utilizing synthetic media securely sealed in a die-cur beverage board frame. The filter shall be 2 inch (50mm) thick.

The filter shall be supplied with a 50mm deep galvanised steel cell (holding) frame with quick release clamps or hinge type spring clips for positive airtight clamping of the filter.

The filter shall have a rated face velocity of 500 FPM (2.5m/s) with maximum initial resistance of 0.30 inch of WG (75 Pa) and final pressure drop of 0.72 inch of WG (200 Pa).

5. Medium Efficiency Bag Filters (Filter Class F6 to EN 779):

Filters shall conform to filter Class F6 to CEN Standard EN 779, & provide Average Atmospheric Dust Spot Efficiency of 60% to 80%.

These filters shall be extended surface air filters, pocket type having a minimum of 8 pockets; with either a retainer device designed to give full top, bottom and side support to each pleat, or with the pleats so designed as not to require a supporting retainer. Retainer device, if used, shall be of galvanised wire with PVC coating.

Filter media shall be ultra-fine fibreglass specifically manufactured for filtration.

Filters shall be provided with holding frames lined with sealing gasket with quick-release clamps, for side access application, designed to ensure a positive seal against leakage of unfiltered air. The filters shall have a rated filter face velocity of 500 FPM (2.5 m/s), providing a maximum Initial Resistance of 0.24 inch of WG (60 Pa) and a recommended final resistance of 1 inch WG (250 Pa). Filter depth shall be 22 inches (560mm).

6. Medium Efficiency Bag Filters (Filter Class F7 to EN 779):

Filters shall conform to filter Class F7 to CEN Standard EN 779, & provide Average Atmospheric Dust Spot Efficiency of 80% to 90%.

These shall be similar to Class F6 Bag Filters as specified above. The filter shall have a rated filter face velocity of 500 FPM (2.5m/s), providing a minimum initial resistance of 0.3 inch of WC (75 Pa), and a recommended final resistance of 1 inch WG (250 Pa).

7. High Efficiency Bag Filters: (Filter Class F8 to EN 779):

Filters shall conform to filter Class F8 to CEN Standard EN 779, & provide Average Atmospheric Dust Spot Efficiency of 90% to 95%.

These shall be similar to Class F6 Bag Filters specified above, except that the filters shall have a minimum of eight pockets and shall have a rated filter face velocity of 500 FPM (2.5 m/s), providing a maximum Initial Resistance of 0.35 inch of WG. (88 Pa), and a recommended final resistance of 1 inch WG (250 Pa). Filter depth shall be 22 inches (560mm).

8. High Efficiency Pleat Filters (Filter Class F9 to EN 779):

Filters shall conform to filter Class F9 to CEN Standard EN 779, & provide Average Atmospheric Dust Spot Efficiency of greater than or equal to 95%. These shall be of high efficiency extended surface rigid type, consisting of galvanised steel holding frame and replaceable filter.

The holding frame shall be of 16-gauge galvanised steel, minimum 70mm in depth, and designed to provide positive seal against leakage of unfiltered air. The frames shall be provided with integral spring type latches to firmly hold the filter against neoprene rubber gaskets.



SPECIFICATIONS

PROJECT NO : 1890
PROJECT TITLE : SSGCL HEAD OFFICE BUILDING, KARACHI
DATED : 20TH APRIL, 2026

The filters shall be made from water-resistant ultra-fine glass fibres. The media shall be pleated and shall have crimped aluminium separators to maintain uniform spacing between pleats. The filter casing shall be of galvanised steel.

The rated filter velocity shall be 500 FPM (2.5 m/s) providing a maximum Initial Resistance of 0.60 inch of WG (150 Pa) and a Recommended Final Resistance of 1.2 inch WG (300Pa). Filter depth shall be 292mm.

9. Activated Carbon Filters:

These filters shall consist of activated carbon filter cells for removal of odour and harmful vapours by adsorption process.

Filter housing shall be constructed of 16 gauge galvanised steel sheet with internal stiffener bars. Top and bottom slide track inserts shall be one-piece moulded corrosion resistant plastic.

Filter cell frame shall consist of moisture resistant chipboard with neoprene seals. The activated carbon cells shall be of wedge formation securely fixed to the frames. The activated carbon used shall have cylindrical shaped granules. Filter shall be minimum 1 inch (25mm) thick. Carbon trays shall be rechargeable and manufactured of high impact plastic with internal separators to prevent settling of the carbon beds. Two beads of caulking, one on either side of the mounting holes and around the framework to allow the filters to seal against each other shall be provided.

The filters shall have a rated filter velocity of 500 fpm (2.5 m/s), providing a maximum initial resistance of 0.5 inch of WG (125 Pa). Minimum service life shall be one year.

10. Reference Specification:

The following specifications shall be construed to be part of these specifications.

- 23 05 01 - Basic Mechanical Requirement
- 23 05 02 - Basic Mechanical Materials and Methods

END OF SECTION 23 41 10



SPECIFICATIONS

PROJECT NO : 1890
PROJECT TITLE : SSGCL HEAD OFFICE BUILDING, KARACHI
DATED : 20TH APRIL, 2026

WATER COOLED CENTRIFUGAL CHILLERS-VARIABLE SPEED

PART-1: GENERAL

1.1 Section Scope:

- A. The contractor shall supply microprocessor/microcontroller/PLC based electric operated water cooled centrifugal chillers of the capacity and performance as given in the CENTRIFUGAL CHILLER EQUIPMENT DATA SHEET. Manufacturer's are advised to focus on quoting high efficiency chillers requiring the least kw/TR, as the selection of the chiller shall be based on life cycle cost analysis.
- B. Chillers shall use refrigerant 134a/410c and 514a as specified in the data sheet.
- C. The Contractor shall also supply a Chiller Plant Controller/Optimizer to sequence all the centrifugal chillers and operate them to achieve maximum plant efficiency.
- D. Facilitation to Company Representative at Karachi port during clearing of equipment.
- E. Commissioning & Testing.
- F. Test Run.
- G. Service Contract.

1.2 Submittals:

A. Tendering Stage Submittals

1. Bidder shall submit the following documentation:
 - a) Equipment catalogue/drawings having specifications, selection data; assembled equipment dimensions, operating weights and load distribution, required service and access clearances etc
 - b) Factory certified selection documentation.
 - c) Product data in table form indicating NPLV (kW/ton), amount of refrigerant charge (kg), and amount of oil required (Litre), etc.
 - d) Product data indicating options and specialties, electrical requirements and wiring diagrams and connections
 - e) Electrical control panel diagram and information
 - f) Microprocessor (Microcontroller) control panel information
 - g) Crating information
 - h) Shipment information;
 - i) Certificate of Origin.
 - j) Equipment Compliance Statement & Quality Assessment Forms supplied by the Engineers, dully filled.
 - k) Statement of conformance to specifications and deviation from specifications.

B. Construction Stage Submittals

1. Contractor shall submit the following documentation at appropriate times:



SPECIFICATIONS

PROJECT NO : 1890
PROJECT TITLE : SSGCL HEAD OFFICE BUILDING, KARACHI
DATED : 20TH APRIL, 2026

- a) Certified dimensional drawings of the equipment.
- b) Equipment Installation, Operation & Maintenance Manual.
- c) Field Wiring Diagram.
- d) Provide manufacturer's assurance that equipment will operate over complete range (10 percent - 100 percent rated capacity) without the use of hot gas bypass and without surging.
- e) Part load performance data in accordance with ARI 550/590-03. Plot chiller performance from 100 percent to 10 percent in 10 percent increments with constant entering condenser water temperatures at 86, +80 +75 + 70 + 65 + 60 degrees F for every 10 percent reduction.
- f) Chiller load performance data in accordance with ARI relief with a capacity reduction from 100 percent to 10 percent in 10 percent increments.
- g) Chiller Sound: The chiller shall be rated for sound as per AHRI 575-94. The part-load sound should not exceed the full load sound \pm 1dBA. The chiller supplier should ensure proper insulation on the compressor/condenser to meet the above requirement.
- h) Factory Performance Test Protocol

C. Close-Out Submittals

1. Contractor shall submit the following documentation at the close-out of the project:
 - a) Commissioning Reports, as per manufacturer's standard, duly signed by the commissioning engineer.
 - b) 5 sets of operation & maintenance manual.
 - c) 5 sets of service/spare parts manual.

1.3 Reference Standards:

- A. ANSI/ASHRAE STANDARD 15-1994 - Safety Code for Mechanical Refrigeration.
- B. ANSI/ASHRAE 90A - Energy Conservation in New Building Design.
- C. ASME SEC VIII - Boiler and Pressure Vessel Code or applicable code as per country of origin.
- D. ANSI/UL 465 - Central Cooling Air Conditioners.
- E. AHRI STANDARD 550/590-98 - Centrifugal, Helical Rotary, Scroll, and Reciprocating Water Chillers.
- F. AHRI Standard 575-94 Method of Measuring Machinery Sound within Equipment Rooms.
- G. AFBMA 9 - Load Ratings and Fatigue Life of Roller Bearings.
- H. ASHRAE STANDARD 34 - Number Designation and Safety Classification of Refrigerants.

1.4 Quality Assurance:

A. Standard & Regulatory Requirements

1. Conform to AHRI Standard 550/590-98 code for rating and testing of water chillers.

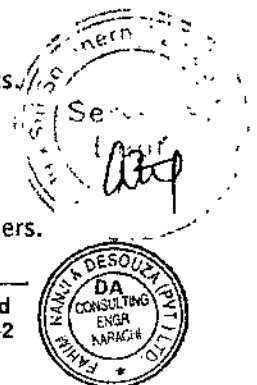

SPECIFICATIONS

PROJECT NO : 1890
PROJECT TITLE : SSGCL HEAD OFFICE BUILDING, KARACHI
DATED : 20TH APRIL, 2026

2. Conform to UL 1995 for Safety for Heating and Cooling Equipment.
3. Conform to ANSI/ASME SECTION VIII Boiler and Pressure Vessel Code for construction and testing of centrifugal chillers as applicable or applicable code as per country of origin.
4. Conform to ANSI/ASHRAE STANDARD 15-1994 code for construction and operation of centrifugal chillers.
5. Conform to ASHRAE Guideline 3 - Reducing Emission of Halogenated Refrigerants in Refrigeration and Air-conditioning Equipments and Systems
6. Conform to National Electrical Code (N.E.C.)
7. Unit shall bear the AHRI Certification Label for Water Chillers as applicable.
8. Equipment manufacturer shall be a company specializing in manufacture, assembly, and field performance of provided equipment with a minimum of five (5) years experience.
9. Chiller Sound: The chiller shall be rated for sound as per AHRI 575-94. The part-load sound should not exceed the full load sound \pm 1dBA. The chiller supplier should ensure proper insulation on the compressor/condenser to meet the above requirement.

B. Factory Test

1. Each chiller shall undergo a series of standard factory tests to ensure that the unit is leak tight, that all electrical components operate as intended, and that every aspect of unit fabrication meets stringent quality standards in accordance with good practice and the manufacturer's quality assurance requirements.
2. All machine wiring shall undergo an insulation resistance test. The machine control centre and all electrical components shall also be functionally tested to verify continuity and proper electrical operation.
3. Final assembly inspection shall consist of verifying dimensional accuracy, and that all valves, controls, instrumentation, pumps, purge components, name-plate and all other machine components have been properly installed on the machine.

C. Factory Performance Test (FPT)

1. If indicated in the BOQ, one chiller of each model or capacity shall be factory tested by the manufacturer at his works at specified full load conditions and part load conditions (part load only if indicated in the BOQ), in accordance with AHRI 550/590 & 551/591.
2. The Contractor shall submit the full factory testing protocol to the Engineer two months prior to the date of testing.
3. Full/part load operating parameters to be verified during factory performance test shall demonstrate complete conformance of the chiller in accordance with specifications.

SPECIFICATIONS

PROJECT NO : 1890
PROJECT TITLE : SSGCL HEAD OFFICE BUILDING, KARACHI
DATED : 20TH APRIL, 2026

4. The manufacturer shall provide the test result obtained having the testing immediately & submit a complete Performance Test Report within two weeks of the completion of the testing.
5. In the event that Performance Testing results do not meet the capacity requirements in accordance with AHRI 550/590 & 551/591, the manufacturer shall make necessary rectifications on the chillers/test set-up and put the modified chillers or test set-up to re-test until specified capacity of the chillers are met. This shall apply to all chillers that are under order by the Company Representative.
6. If the manufacturer not be able to meet the specified capacity requirements, the contractor hereby agrees to a reduction in cost of the chillers @1.5 times the quoted price per ton of the chiller calculated on the shortfall capacity.
7. The Company Representative shall be at liberty to have a third party witnessing of the test.
8. All cost of testing, modifications and re-testing shall be borne by the Contractor.

D. Factory Acceptance Test (FAT)

1. If indicated in the BOQ, the factory Performance Test shall be carried out in the presence of Company Representative and the Engineer and shall be called the Factory Acceptance Test, and the test results, if satisfactory, shall be signed by the Company Representative and Engineer's representative.
2. The number of representatives from the Company Representative & contractor shall be a minimum of one each or additional as indicated in the special terms & condition and BOQ.
3. The cost of travelling, boarding & lodging of the Company Representative & Engineer's representatives from Pakistan to the factory and back shall be borne by the Contractor.
4. Additionally factory Performance Test shall also be witnessed by representatives appointed by Company Representative for third party inspection. If the test results are satisfactory shall be signed by the third party inspection team as acceptance of chillers by the Company Representative. Responsibilities of the 3rd party inspection firm are attached after SSGC general terms and conditions.
5. The cost of travelling & lodging of the Company Representative third party inspection team to the factory shall be borne by the Company Representative.

E. Site Training of Company Representative Staff

1. Training will be carried out for executives and staff not extended beyond 10 persons.
2. The proposed training programme shall be submitted in advance to Company Representative/ Engineer for comment and approval to ensure that the specific operation and maintenance requirements of the chillers are adequately addressed.

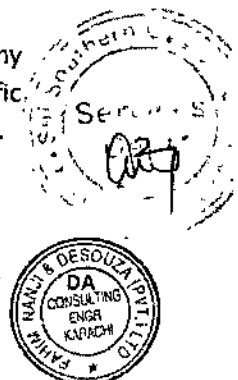

SPECIFICATIONS

PROJECT NO : 1890
PROJECT TITLE : SSGCL HEAD OFFICE BUILDING, KARACHI
DATED : 20TH APRIL, 2026

3. The length of the training shall be in accordance with the standard training course offered by the manufacturer and to be mutually agreed by the Company Representative, to certify the Company Representative representative as a manufacturer certified chiller operator & technician.
4. Training will be carried out at a reputable venue within Karachi premises.

1.5 Delivery, Storage, and Handling:

- A. Chiller shall be shipped with nameplates indicating name of manufacturer, model size, serial number, and all other pertinent machine data.
- B. Chiller shall include shipping rails as standard for ease of sliding or moving a unit into position to simplify installation.
- C. Protect internals from entry of foreign material by temporary caps on flanged openings.

1.6 Warranty:

- A. Manufacturer shall guarantee the chiller against defects in materials and/or workmanship for a period as stated in Section-300, Special terms & condition.
- B. The Engineer should establish a mechanism to verify and validate the performance of the 375RT chillers during the commissioning phase, ensuring compliance with design requirements.
- C. Any part/equipment/allied component and accessory failure within one month after commissioning would be treated as manufacturing fault and must be replaced.
- D. Contractor shall provide availability of spares and technical support for at least 10 (Ten) years.

PART-2: PRODUCTS

2.1 General:

- A. The contractor shall furnish and install factory assembled & tested centrifugal water chillers as per these specifications & as per CENTRIFUGAL CHILLER EQUIPMENT DATA SHEET. The units shall produce the specified tonnage per the scheduled data in accordance with AHRI 550/590-98.
- B. These specifications are based on chillers using refrigerant R34a/410c and R514a as specified in the data sheet. Chillers with equivalent specifications using Refrigerant R123 may also bid, as the selection of the chillers will be made after a detailed review of technical proposal and financial quotes and comparative life cycle costing of all quoted chillers.
- C. Performance shall be certified or rated in accordance with the latest edition of AHRI Standard 550/590 as applicable.
- D. Only chillers that are listed in the AHRI Certification Program for Water Chilling Packages Using the Vapor Compression Cycle are acceptable.
- E. Each unit will be completely factory-packaged including evaporator, variable speed drive, condenser, compressor, motor, microprocessor control centre and all interconnecting unit piping and wiring. The chiller will be painted prior to shipment and will be packaged to protect the unit during shipment.



SPECIFICATIONS

PROJECT NO : 1890
PROJECT TITLE : SSGCL HEAD OFFICE BUILDING, KARACHI
DATED : 20TH APRIL, 2026

- F. For chillers with dual compressors, provide each compressor with a dedicated motor and motor controller, and provide for continued operation when either compressor- drives assembly fails or is being serviced.

2.2 Refrigerant:

- A. Provide centrifugal chillers utilizing high efficiency, zero Ozone Depleting Potential (ODP), refrigerant HFC-134a, 410c and 514a as specified in the data sheet.
- B. The initial charge of refrigerant and oil will be shipped loose for each unit and charged by the chiller supplier service technician during start-up. The oil charge, relief device, and other miscellaneous materials shall be packed separately.
- C. Spare refrigerant shall be supplied with the Chillers as indicated in Data sheet i.e. 50% of one chiller.

2.3 Compressors:

- A. The compressor will be a single-stage or double-stage centrifugal type powered by an open-drive, Semi-hermetic or hermetic electric motor. The housing will be fully accessible with vertical circular joints, with the complete operating assembly removable from the compressorhousing. Compressor castings shall be designed for a minimum 235 psig working pressure and hydrostatically pressure tested at a minimum 352 psig for R-134a units.
- B. The rotor assembly will consist of a heat treated alloy steel drive shaft and impeller shaft with cast alloy aluminium, fully shrouded impeller. The impeller will be designed for balanced thrust, dynamically balanced and over-speed tested for smooth, vibration free operation. Insert-type journal and thrust bearings will be fabricated of aluminium alloy, precision bored and axially grooved.
- C. Internal single helical gears with crowned teeth will be designed so that more than one tooth is in contact at all times to provide even load distribution and quiet operation. Each gear will be individually mounted in its own journal and thrust bearings to isolate it from impeller and motor forces. Shaft seal shall be provided in double bellows, double-seal, and cartridge-type.
- D. A gravity-fed oil reservoir will be provided into the top of the compressor to provide lubrication during coast-down in the case of a power failure.
- E. Capacity control shall be accomplished by the adaptive capacity control, providing optimal relationship between compressor speed and inlet pre-rotation vane position. Control shall automatically compensate for adverse operating conditions, such as fouled tubes and adjust to prior operation after correction of these conditions. The unit will be provided with variable refrigerant orifice technology to allow stable chiller operation with entering condenser water temperatures down to 13°C, and shall be capable of continuous, reliable operation with low temperature cooling tower water during part-load operation in accordance with AHRI Standard 550/590. Pre-rotation vane position will be automatically controlled by an external electric actuator to maintain constant leaving chilled water temperature.
- F. Part Load Performance: Provide chiller efficiencies at 10% load increments at the following entering condenser water temperatures (ECWTs): 90°F 85°F, 80, 75, 70, 65

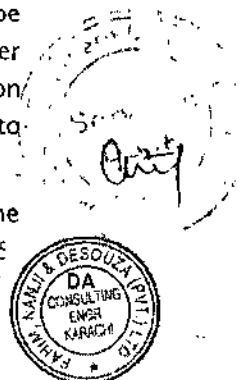

SPECIFICATIONS

PROJECT NO : 1890
PROJECT TITLE : SSGCL HEAD OFFICE BUILDING, KARACHI
DATED : 20TH APRIL, 2026

60, 55 and minimum possible. Demonstrate that the chiller will provide more than 100% design capacity at the minimum possible ECWT. The chiller should be capable of unloading till 15% at constant condenser entering water temperature without the use of hot gas bypass valve.

- G. Compressors using an unloading system that requires dynamic penetrations through the compressor housing or linkages, or both that must be lubricated and adjusted are acceptable provided the manufacturer provides a five-year inspection agreement consisting of semi-annual inspection, lubrication, and annual change out of any compressor seals.

2.4 Motors:

- A. Power shall be supplied to the compressor motor at 400V/3ph/50Hz.
- B. Motors shall be hermetic drive, semi-hermetic drive or open drive conforming to the specifications given below.
- C. Hermetic & Semi-Hermetic Drive Motors:
1. Provide chiller with a driveline designed for service including and electric motor that is outside of the refrigerant stream.
 2. Hermetic motors must include motor winding temperature RTDs, one per phase.
 3. In Semi Hermetic Motor stator shall be arranged for service or removal with only minor compressor disassembly and without removing main refrigerant piping connections.
- D. Open Drive Motors:
1. The open-drive motor will be an open drip-proof (ODP), squirrel cage, induction type.
 2. If an open drive motor is provided, the manufacturer shall provide a double seal shaft seal and a five-year parts and labor warranty against any shaft seal or other compressor housing penetration leaks.
 3. Additionally a shaft seal leakage containment system shall be provided consisting of an oil reservoir to collect oil and refrigerant that leaks past the seal, with a float device to open when the reservoir is full, directing the refrigerant/ oil mixture back into the into the compressor housing. A refrigerant sensor shall be located next to the open drive seal to detect leaks.
 4. The open motor shall be provided with a D-flange, bolted to a cast iron adapter mounted on the compressor to allow the motor to be rigidly coupled to the compressor to provide factory alignment of motor and compressor shafts.
 5. Motor drive shaft will be directly connected to the compressor shaft with a flexible disc coupling. Coupling will have all metal construction with no wearing parts to assure long life, and no lubrication requirements to provide low maintenance.
 6. Open Drive motors must include motor winding temperature RTDs, one per phase.

2.5 Evaporator:

- A. Evaporator will be of the shell & tube, flooded type or hybrid flooded-falling film type



SPECIFICATIONS

PROJECT NO : 1890
PROJECT TITLE : SSGCL HEAD OFFICE BUILDING, KARACHI
DATED : 20TH APRIL, 2026

- designed for 180 psig working pressure on the refrigerant side. Shell will be fabricated from rolled carbon steel plate with fusion welded seams; have carbon steel tube sheets, drilled and reamed to accommodate the tubes; and intermediate tube supports spaced no more than four feet apart. The refrigerant side will be designed, tested and stamped in accordance with ASME Boiler and Pressure Vessel Code, Section VIII- Division 1 or applicable code as per country of origin.
- B. Tubes shall be high-efficiency, internally and externally enhanced type having plain copper lands at all intermediate tube supports to provide maximum tube wall thickness at the support area. Each tube will be roller expanded into the tube sheets providing a leak proof seal, and be individually replaceable. Water velocity through the tubes will not exceed 12 fps.
 - C. Two liquid level sight glasses will be located on the side of the shell to aid in determining proper refrigerant charge.
 - D. Aluminium mesh eliminators will be located above the tube bundle to prevent liquid refrigerant carryover to the compressor.
 - E. The evaporator will have a refrigerant relief device sized to meet the requirements of ASHRAE 15 Safety Code for Mechanical Refrigeration.
 - F. The heat exchanger construction will comply with the requirements of ASHRAE 15 Safety Code for Mechanical Refrigeration.
 - G. Water boxes for the evaporator shall be removable, compact-type to permit tube cleaning and replacement. Stub-out water connections will be provided with either Victaulic grooves or flanges. Vent and drain connections with plugs will be provided on each water box.
 - H. Anti-sweat insulation will be attached to the evaporator shell, flow chamber, tube sheets, suction connection, and (as necessary) to the auxiliary tubing at the factory. The insulation will be a flexible, closed-cell plastic type, 20mm thick, applied with vapor-proof cement. The insulation will normally prevent sweating in environments with relative humidity up to 90% at dry bulb temperatures upto 40°C. Insulation for water boxes shall be supplied and installed in the field by mechanical contractor for all forms of shipment.
 - I. Refrigerant flow to the evaporator shall be controlled by a variable orifice for improving unloading capabilities.

2.6 Condenser:

- A. Condenser will be of the shell&tube type, two-pass arrangement, designed for 235 psig working pressure on the refrigerant side.
- B. Shell will be fabricated from rolled carbon steel plate with fusion welded seams; have carbon steel tube sheets, drilled and reamed to accommodate the tubes; and intermediate tube supports spaced no more than four feet apart.
- C. The refrigerant side will be designed, tested and stamped in accordance with ASME Boiler and Pressure Vessel Code, Section VIII-Division 1 or applicable code as per country of origin.
- D. Tubes shall be high-efficiency, internally and externally enhanced type having plain



Fahim, Nanji & deSouza (Pvt.) Ltd.
Consulting Engineers

Water Cooled Centrifugal Chillers-Variable Speed
Section 23 64 17-8



SPECIFICATIONS

PROJECT NO : 1890
PROJECT TITLE : SSGCL HEAD OFFICE BUILDING, KARACHI
DATED : 20TH APRIL, 2026

copper lands at all intermediate tube supports to provide maximum tube wall thickness at the support area. Each tube will be roller expanded into the tube sheets providing a leak-proof seal, and be individually replaceable. Water velocity through the tubes will not exceed 12 fps.

- E. Condenser head shall be provided with marine water boxes (As indicated in Datasheet) or head covers shall be hinged at both ends of condenser shell. The hinges shall be installed at the top (12 o'clock position) so that the condenser head is supported and is able to swing free of the shell. The hinged support connection at top of the condenser head shall have a pivot assembly, so that the head can be rotated when hanging from the support beam.
- F. Inside of condenser water boxes and head covers should have an enamel/polymer coat of paint/linings resistant to cooling tower treatment chemicals.
- G. A magnesium anode of sufficient size to account for electrolysis shall be placed inside of condenser section. The attachment device for magnesium anode shall be a threaded rod with nut and washer. Rods should be welded to inside of head and coated with same material as the inside of the condenser head cover. Nut and washers shall be of plastic material.
- H. Stub-out water connections will be provided with either having Victaulic grooves or flanges. Vent and drain connections with plugs will be provided on each water box.
- I. Provide refrigerant over-pressurization safety relief. Re-seating refrigerant pressure relief valves are the preferred option over rupture discs.
- J. The variable refrigerant orifice technology shall allow stable chiller operation with entering condenser water temperatures down to 12.8°C.

2.7 Lubrication System:

- A. Lubrication oil shall be force fed to all compressor bearings, gears and rotating surfaces by an external variable speed oil pump. The oil pump shall vary oil flow to the compressor based on operating and stand by conditions, ensuring adequate lubrication at all times.
- B. The oil pump shall operate prior to start up, during compressor operation and during coast down. Compressor shall have an auxiliary reservoir to provide lubrication during coast down in case of power failure.
- C. An oil reservoir separate from the compressor, shall contain a submersible oil pump and an oil heater, thermostatically controlled to remove refrigerant from the oil.
- D. Oil shall be filtered with externally mounted 0.5 micron replaceable cartridge oil filter equipped with service valves. Filters shall be duplex with one standby for hot replacement. Oil cooling shall be done via refrigerant cooled oil cooler with all piping factory installed. Oil side of the oil cooler shall be provided with service valves. An automatic oil return system to recover any oil that may have migrated to the evaporator shall be provided. Oil piping shall be completely factory installed and tested.

SPECIFICATIONS

PROJECT NO : 1890
PROJECT TITLE : SSGCL HEAD OFFICE BUILDING, KARACHI
DATED : 20TH APRIL, 2026

2.8 Insulation:

- A. Factory-applied insulation over cold surfaces of liquid chiller components including evaporator shell and suction line. Liquid nozzles and water boxes shall be insulated by contractor after pipe installation.
- B. Insulation shall be closed-cell, flexible, UV protected, thermal insulation complying with ASTM C 534 type 2 (Sheet) for preformed flexible elastomeric cellular thermal insulation in sheet and tubular form and provided with cladding.
- C. Insulation thickness shall be a minimum ¾" (19mm) or as required to prevent sweating at 90% RH at 40°C.

2.9 Controls:

- A. The chiller shall be controlled by a stand-alone microprocessor/microcontroller/PLC based control centre. The chiller control panel shall provide control of chiller operation and monitoring of chiller sensors, actuators, relays and switches.
- B. The (VDU) of control panel shall be more than 250mm diagonal color liquid crystal display (LCD) surrounded/embedded "soft/touch" keys. The screen shall detail all operations and parameters, using a graphical representation of the chiller and its major components. Control Panel language shall be English. Data shall be displayed in either English or Metric units as per choice of the operator.
- C. Smart Freeze Point Protection shall run the chiller upto 2.2°C leaving chilled water temperature, and not have nuisance trips on low water temperature. The program and sensor shall monitor the chiller water temperature to prevent freeze up.
- D. The panel shall display countdown timer messages so the operator knows when functions are starting and stopping. Every programmable point shall have a pop-up screen with the allowable ranges, so that the chiller cannot be programmed to operate outside of its design limits.
- E. The chiller control panel shall also provide:
 - 1. System operating information including:
 - a. entering and leaving chilled water temperature
 - b. entering and leaving condenser water temperature
 - c. evaporator and condenser saturation temperature
 - d. differential oil pressure
 - e. percent motor current
 - f. compressor discharge temperature
 - g. oil reservoir temperature
 - h. compressor thrust bearing positioning and oil temperature
 - i. operating hours
 - j. number of compressor starts

Services
[Signature]



SPECIFICATIONS

PROJECT NO : 1890
PROJECT TITLE : SSGCL HEAD OFFICE BUILDING, KARACHI
DATED : 20TH APRIL, 2026

2. Digital programming of set points through the universal keypad including:
 - a. leaving chilled water temperature
 - b. percent current limit
 - c. pull-down demand limiting
 - d. six-week schedule for starting and stopping the chiller, pumps and tower
 - e. remote reset temperature range
3. Status messages indicating:
 - a. system ready to start
 - b. system running
 - c. system coast down
 - d. system safety shutdown-manual restart
 - e. system cycling shutdown-auto restart
 - f. system pre-lube
 - g. start inhibit
4. The text displayed within the system status and system details field shall be displayed as color coded message to indicate severity: red for safety fault, orange for cycling faults, yellow for warnings, and green for normal messages.
5. Safety shutdowns enunciated through the display and the status bar, and consisting of system status, system details, day, time, cause of shutdown, and type of restart required. Safety shutdowns with a fixed speed drive shall include:
 - a. evaporator - low pressure
 - b. evaporator - transducer or leaving liquid probe
 - c. evaporator - transducer or temperature sensor
 - d. condenser - high pressure contacts open
 - e. condenser - high pressure
 - f. condenser - pressure transducer out of range
 - g. auxiliary safety - contacts closed
 - h. discharge - high temperature
 - i. discharge - low temperature
 - j. oil - high temperature
 - k. oil - low differential pressure
 - l. oil - high differential pressure
 - m. oil - sump pressure transducer out of range
 - n. oil - differential pressure calibration
 - o. oil - variable speed pump - pressure set point not achieved



SPECIFICATIONS

PROJECT NO : 1890
PROJECT TITLE : SSGCL HEAD OFFICE BUILDING, KARACHI
DATED : 20TH APRIL, 2026

- p. control panel - power failure
 - q. motor or starter - current imbalance
 - r. thrust bearing - proximity probe clearance
 - s. thrust bearing - proximity probe out - of - range
 - t. thrust bearing - high oil temperature
 - u. thrust bearing - oil temperature sensor
 - v. watchdog - software reboot
- 5.1 Safety shutdowns with a Variable Speed Drive (VSD) shall include:
- a. VSD shutdown - requesting fault data
 - b. VSD - stop contacts open
 - c. VSD - 105% motor current overload
 - d. VSD - high phase A, B, C inverter heat sink temp.
 - e. VSD - high converter heat sink temperature*
6. Cycling shutdowns enunciated through the display and the status bar, and consisting of system status, system details, day, time, cause of shutdown, and type of restart required. Cycling shutdowns with a fixed speed drive shall include:
- a. multiunit cycling - contacts open
 - b. system cycling - contacts open
 - c. oil - low temperature differential
 - d. oil - low temperature
 - e. control panel - power failure
 - f. leaving chilled liquid - low temperature
 - g. leaving chilled liquid - flow switch open
 - h. motor controller - contacts open
 - i. motor controller - loss of current
 - j. power fault
 - k. control panel - schedule
 - l. starter - low supply line voltage
 - m. proximity probe - low supply voltage
 - n. oil-variable speed pump - drive contacts open
- 6.1 Cycling shutdowns with a VSD shall include:
- a. VSD shutdown - requesting fault data
 - b. VSD - stop contacts open
 - c. VSD initialization failed
 - d. VSD - high phase A,B,C instantaneous current



SPECIFICATIONS

PROJECT NO : 1890
PROJECT TITLE : SSGCL HEAD OFFICE BUILDING, KARACHI
DATED : 20TH APRIL, 2026

- e. VSD - phase A,B,C gate driver
 - f. VSD - single phase input power
 - g. VSD - high DC bus voltage
 - h. VSD - pre charge DC bus voltage imbalance
 - i. VSD - high internal ambient temperature
 - j. VSD - invalid current scale selection
 - k. VSD - low phase A, B, C inverter heat sink temp.
 - l. VSD - low converter heat sink temperature
 - m. VSD - pre-charge - low DC bus voltage
 - n. VSD - logic board processor
 - o. VSD - run signal
 - p. VSD - serial communications
7. Security access to prevent unauthorized change of set points, to allow local or remote control of the chiller, and to allow manual operation of the pre-rotation vanes and oil pump shall be provided. Access shall be through ID and password recognition, defined by three different levels of user competence: view, operator, and service.
8. Trending data with the ability to customize points of once every second to once every hour. The panel shall trend up to 6 different parameters from a list of over 140, without the need of an external monitoring system.
9. The operating program shall be stored in non-volatile memory (EPROM) to eliminate reprogramming the chiller due to AC power failure or battery discharge. Programmed set points shall be retained in lithium battery-backed RTC memory for a minimum of 11 years with power removed from the system.
10. A fused connection through a transformer in the compressor motor starter to provide individual over-current protected power for all controls.
11. A numbered terminal strip for all required field interlock wiring.
12. An RS-232 port to output all system operating data, shutdown/cycling message, and a record of the last 10 cycling or safety shutdowns to a field-supplied printer. Data logs to a printer at a set programmable interval. This data shall be capable of being pre-programmed to print from 1 minute to 1 day. In addition to that, provision of one additional USB/Ethernet port for remote/localized connectivity to be provided.
- F. The microprocessor/microcontroller/PLC based shall be capable of communicating with the Building Management System (BMS) using BACnet over IP protocol. Communication wirings from Control Panel to building BMS are to be provided and installed by the BMS contractor, who shall land wires in control panel cabinet where the chiller supplier technician will make the final connections. The chiller supplier technician will test interface communication signal after installation. BMS representative must be present at



SPECIFICATIONS

PROJECT NO : 1890
PROJECT TITLE : SSGCL HEAD OFFICE BUILDING, KARACHI
DATED : 20TH APRIL, 2026

time of commissioning.

- G. Provision of remote online monitoring of chillers to be provided for the entire life span of chillers.
- H. System must be capable to withstand Emergency shut down (ESD) or abrupt power failure protection without the use of external batteries or UPS.

2.10 Compressor Motor Starter:

- A. The chillers shall be supplied with 400V/50Hz Variable Speed Drive (VSD) factory installed on the chiller. The VSD shall be provided with harmonic filters that limit electrical power supply distortion to comply with the guidelines of IEEE Std. 519-1992. The filters shall be unit mounted within the same NEMA -1 enclosure and shall be UL listed.
- B. VSD will vary the compressor motor speed by controlling the frequency and voltage of the electrical power to the motor. The adaptive capacity control logic shall automatically adjust motor speed and compressor pre-rotation vane position independently for maximum part-load efficiency by analyzing information fed to it by sensors located throughout the chiller.
- C. Drive with input frequency of 50Hz and output of 60 Hz with a 60Hz chiller motor will not be acceptable.
- D. Drive shall be PWM type utilizing IGBT's with a power factor of 0.95 or better at all loads and speeds.
- E. The VSD will be unit mounted in a NEMA 1 enclosure with all power and control wiring between the drive and chiller factory installed, including power to the chiller oil pump. Field power wiring shall be a single point connection and electrical lugs for incoming power wiring will be provided. The entire chiller package will be UL listed.
- F. The following features will be provided:
 - 1. Door interlocked circuit breaker capable of being padlocked.
 - 2. UL listed ground fault protection.
 - 3. Over voltage and under voltage protection.
 - 4. 3-phase sensing motor over-current protection.
 - 5. Single phase protection.
 - 6. Insensitive to phase rotation.
 - 7. Over temperature protection.
- G. Digital readout at the chiller unit control panel of output frequency, output voltage, 3-phase output current, input Kilowatts and Kilowatt-hours, -self-diagnostic service parameters. Separate meters for this information will not be acceptable.
- H. KW Meter - The unit's input power consumption will be measured and displayed digitally via the unit's control panel. The KW meter accuracy shall be $\pm 3\%$ of reading. KW meter scale shall be 0 - 750 kW.



SPECIFICATIONS

PROJECT NO : 1890
PROJECT TITLE : SSGCL HEAD OFFICE BUILDING, KARACHI
DATED : 20TH APRIL, 2026

- I. KWh Meter - The unit's cumulative input power consumption shall be measured and displayed digitally via the unit's control panel. The KWh meter shall be re-setable and its accuracy shall be $\pm 3\%$ of reading. KWh meter scale shall be 0 - 999,999 kWh.
- J. Ammeter - Simultaneous three-phase true RMS digital readout via the unit control panel. Three current transformers provide isolated sensing. The ammeter accuracy shall be $\pm 3\%$ of reading. Ammeter scale shall be 0 - 550 A RMS.
- K. Voltmeter - Simultaneous three-phase true RMS digital readout via the unit control panel. The voltmeter accuracy shall be $\pm 3\%$ of reading. Voltmeter scale shall be 0 - 500 VAC.
- L. Elapsed Time Meter-Digital readout of the unit's elapsed running time (0 - 800,000 hours, re-setable) shall be displayed via the unit control panel.
- M. Provide chillers with quick start control enabling the chiller controller to rapidly restart and load the chiller and deliver chilled water at set point temperature following a power interruption event. The quick start feature shall ensure pre-rotation (capacity control) vanes remain open following a power interruption event and quick ramp up speed logic is employed to facilitate shortest time to deliver chilled water at set point temperature. Manufacturers must be able to demonstrate chiller start time improvements with the quick start feature enabled on an ARI certified test block fully simulating power-fault, power service return, restart time, and capacity control to produce desired chilled water temperature.
- N. The Variable Speed Drive shall be water cooled or air-cooled designed to remove heat from the VSD for proper operation.

2.11 Refrigerant Monitor:

- A. Provide calibrated, refrigerant monitor for specific refrigerant used, capable of detecting concentrations of 10 ppm for low level detection.
- B. Provide monitor with audible and visual alarms that activate at a value corresponding to the TLV of the refrigerants in use. The alarm system shall annunciate visual and audible alarms inside the machinery room and outside each entrance to the room.
- C. Monitor shall have the capability of detecting, alarming and controlling from 0-50 ppm. Digital display accuracy shall be within one (1) ppm.
- D. Monitor shall require only minimum maintenance.
- E. Recalibrate no more than once every five (5) years.
- F. Re-zeroing no more than once every week.
- G. Monitor shall be capable of operation in ambient temperatures from 5 to 45 degrees C.
- H. Outputs:
 - 1. Two (2) analog set-points and three (3) binary with individual closure set-points.
 - 2. Connect one alarm contact to the BMS to indicate alarm condition into the BMS system.



SPECIFICATIONS

PROJECT NO : 1890
PROJECT TITLE : SSGCL HEAD OFFICE BUILDING, KARACHI
DATED : 20TH APRIL, 2026

3. Remaining alarm contacts shall initiate closure of magnetic motor starters to energize the refrigerant purge supply fan and exhaust fan.

I. Manufacturer's: Bacharach, General Analysis Corporation, Yokogawa, and MSA.

2.12 Refrigerant Pump-Out System:

- A. One refrigerant storage/recycling system shall be provided as a self-contained package consisting of a refrigerant compressor with oil separator, storage receiver, water-cooled condenser, filter drier and necessary valves and hoses to remove, replace, and distil refrigerant. All necessary controls and safety devices are to be a permanent part of the system. Storage receiver shall be sized for the largest chiller in the overall plant.
- B. Pump-out systems shall be complete with transfer pump, condensing unit, and tank constructed in accordance with ASME Code for Unfired Pressure Vessels bearing the National Board stamp.
- C. Pump-out systems shall be supplied and warranted by the chiller manufacturer.

2.13 Spares:

- A. The Contractor shall supply spares suitable for 3 years of normal operation in accordance with the manufacturer's recommendations. The number of spare part sets to be provided shall be as indicated in the BOQ.
- B. Contractor should also quote the critical spares/single point of failure components for maintaining inventory and first major overhaul spares for each chiller.
- C. 5 copies of "Operation and Maintenance" manual shall be supplied with the Equipment.

2.14 Accessories:

- A. The units shall be provided complete with neoprene pad vibration isolators for supporting the unit on the foundations, muffler, crankcase heater, oil failure protection switch, relief valves, water flow switches, and all other standard safety and operational devices necessary for complete automatic operation.
- B. Water Flow Sensors - Thermal type water flow sensors shall be factory mounted in the chilled and condenser water nozzles, and factory wired to the Control Panel. Sensor probe shall be made of 316 Stainless Steel.
- C. The Units shall be provided with sound insulation to cover the compressor and motor housing, the compressor discharge pipe, etc to attenuate the noise of the chiller.
- D. Chilled water and condenser water flow switch shall be field installed and supplied by the chiller manufacturer.

PART-3: EXECUTION

3.1 Commissioning & Testing:

- A. The Contractor shall provide a factory-trained Commissioning Engineer, employed by the chiller manufacturer, to charge chillers with and place unit into operation, and calibrate all controls in accordance with the manufacture's written start-up, operating, and maintenance instructions.

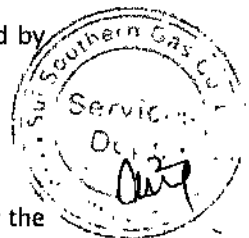

SPECIFICATIONS

PROJECT NO : 1890
PROJECT TITLE : SSGCL HEAD OFFICE BUILDING, KARACHI
DATED : 20TH APRIL, 2026

- B. The Commissioning Engineer shall furnish a start-up log indicating that proper operating sequences and operating and safety control functions are obtained.
- C. The Commissioning Engineer shall subject to the chiller(s) to tests recommended by the manufacturer and these test reports shall be submitted to the Engineers by the Contractor in suitable test forms.

3.2 Test Run:

- A. The Contractor shall Test Run all chillers for a period of one month simultaneously.
- B. The Contractor shall maintain a log of all operating parameters, and provide the same to the Company Representative/ Engineer on a daily basis.
- C. He shall monitor the operation of the chillers closely and monitor that proper operation of the chiller, operating sequences and operating and safety control functions are being obtained. Improper operation, if any shall be specifically identified immediately intimated to the Company Representative/Engineer.
- D. During the Test Run period, the Commissioning Engineer shall instruct the Company Representative personnel in the proper start-up, operating, and maintenance procedures of the chillers.

3.3 Service Contract:

- A. The Contractor shall provide Service Contract services for a period if indicated in the BOQ and in accordance with the Service Contract entered with the Company Representative.

END OF SECTION 23 64 17



SPECIFICATIONS

PROJECT NO : 1890
PROJECT TITLE : SSGCL HEAD OFFICE BUILDING, KARACHI
DATED : 20TH APRIL, 2026

AIR HANDLING UNITS

PART-1: GENERAL

1.1 Scope of Work:

- A. Furnish all labor, materials, plant, equipment and appliances and perform all necessary operations required to execute the work of this section.
- B. This section describes the technical and workmanship requirements for packaged air handling units.
- C. The Contractor shall furnish and install Central Station Air Handling Units of configuration & capacities as scheduled in EQUIPMENT DATA SHEET, and specified hereunder.
- D. Contractor shall be duly responsible for verifying the dimensional suitability of the air-handling units for installation in the space allocated, as shown on the drawings.

1.2 Related Sections:

The Contractor shall become familiar with other sections of the Specifications affecting work of this trade, and shall comply with them in carrying out work under this section.

In particular the following should be referred:

- 23 05 01- Basic Mechanical Requirements
- 23 05 02- Basic Mechanical Materials & Methods
- 23 05 10- Equipment Installation
- 23 05 13- Electric Motors
- 23 05 48- Vibration Isolation & Control
- 23 05 93- Cleaning, Adjusting, Testing and Commissioning
- 23 05 94- Test Run
- 23 33 19- Sound Attenuation
- 23 34 16- Centrifugal Fans
- 23 34 17- Plug Fans
- 23 41 10- Air Filters
- 23 41 33- High Efficiency Particulate Air Filters
- 23 72 13- Air to Air Rotary Heat Exchanger
- 23 72 19- Air to Air Plate Heat Exchanger

1.3 Standards:

The minimum standards for products specified in this section shall be those standards referred to or relevant BSI standards.

- EN 1886:2007- Mechanical Performance of AHU's.
- EN 13053- Rating & Performance of AHU's, components & sections.
- EN 10142- Specification for continuously hot-dip zinc coated low carbon steel sheet
- ARI- Air-Conditioning and Refrigeration Institute.
- ASHRAE 84-78- Method of Testing Air to Air Heat Exchangers.
- AMCA 210-99- Laboratory Methods of Testing Fans for Aerodynamic Performance.
- AMCA 300-85- Test Code for Sound.



Fahim, Nanji & deSouza (Pvt.) Ltd.
Consulting Engineers

Air Handling Units
Section 23 73 10 - 1

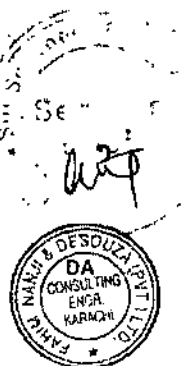

SPECIFICATIONS

PROJECT NO : 1890
PROJECT TITLE : SSGCL HEAD OFFICE BUILDING, KARACHI
DATED : 20TH APRIL, 2026

1.4 Submittals for Review:

- A. Submit samples, specifications, technical compliance statement, computerized selection print-outs, engineering calculations, catalogue cut sheets, description of product and installation method in accordance with the Contract Documents. Submissions shall indicate all dimensions, details of construction, details of installation, relation and connections with adjoining work, performance ratings including fan static, flow, cooling coil and heating coil performance, fan performance, filter details, and sound power levels, etc , as required or directed by the Engineer.
- B. Submit certification documents to substantiate certification specified.
- C. Submit copies of test reports required to be performed on the proposed products.
- D. Submit a list of installation completed where proposed products were used.
- E. Submit Manufacturer's Warranty in conformance to specifications given elsewhere.

1.5 Quality Assurance:

Perform Work in accordance with relevant European or British Standards and industry standard codes.

1.6 Qualifications:

Equipment shall meet or exceed the certification requirements specified.

1.7 Mock-Up:

No requirements.

1.8 Environmental Requirements:

The AHU shall be suitable for the environment in which it is sited and for the air that flows through it.

The external environment shall be considered to be hot (up to 46°C), humid (up to 32°C saturated and moisture contents up to 0.030 kg/kg), dusty (up to 70mg/m³). Installations close to shoreline cities shall also consider a saline environment.

1.9 Warranty:

Submit Manufacturer's Warranty.

PART-2: PRODUCTS

2.1 Approved Manufacturer or Product:

Refer section 23 90 10- List of Approved Manufacturer's.

2.2 Product Requirements:

- A. Air Leakage: Ensure air handling unit is sealed to prevent air leakage at design pressure. The unit shall have air leakage in accordance with EN1886: 2007.
- B. System Resistances: The external system resistances indicated are approximate and the contractor shall calculate the actual resistance based on the coordinated installation drawings and on actual equipment selected.

2.3 Air Handling Unit Construction:

A. General Requirements

All individual components of air handling units shall comply with the appropriate sections of this specification unless otherwise specified in the EQUIPMENT DATA SHEET or on the drawings. The units shall have Eurovent or equivalent certification specified or approved by the Engineer. The complete unit shall be manufactured by



Fahim, Nanji & deSouza (Pvt.) Ltd.
Consulting Engineers

Air Handling Units
Section 23 73 10 - 2



SPECIFICATIONS

PROJECT NO : 1890
PROJECT TITLE : SSGCL HEAD OFFICE BUILDING, KARACHI
DATED : 20TH APRIL, 2026

one manufacturer. The units shall have all necessary sections like supply and return fan sections, mixing sections, cooling coil sections, heating coil sections, empty sections, heat recovery sections, etc to meet the requirements of the EQUIPMENT DATA SHEET and drawings so as to make a complete unit to meet the performance requirements. Each component section of the unit shall be of same matching cross sectional dimension along the length of the unit so as to give a neat appearance and even air flow through each section.

B. Construction Standard

The AHU's shall have the following construction standards in accordance with their application and as per EN 1886: 2007.

S. No.	Parameters for Standards	Classification for Indoor units in air-conditioned space	Classification for Indoor units in NON-air-conditioned space	Classification for Outdoor units in exposed atmosphere	HEPA Filter application
1	Mechanical Strength of casing	≤4mm/m or ≤0.048in/ft (D1)	≤4mm/m or ≤0.048in/ft (D1)	≤4mm/m or ≤0.048in/ft (D1)	≤4mm/m or ≤0.048in/ft (D1)
2	Casing Air Leakage at 400 Pa negative pressure	≤0.44 l/s.m ² or ≤0.00144 ft ³ /s.ft ² (L2)	≤0.44 l/s.m ² or ≤0.00144 ft ³ /s.ft ² (L2)	≤0.44 l/s.m ² or ≤0.00144 ft ³ /s.ft ² (L2)	≤0.15 l/s.m ² or ≤0.0005 ft ³ /s.ft ² (L1)
3	Casing Air Leakage at 700 Pa positive pressure	≤0.63 l/s.m ² or ≤0.0021 ft ³ /s.ft ² (L2)	≤0.63 l/s.m ² or ≤0.0021 ft ³ /s.ft ² (L2)	≤0.63 l/s.m ² or ≤0.0021 ft ³ /s.ft ² (L2)	≤0.22 l/s.m ² or ≤0.00072 ft ³ /s.ft ² (L1)
4	Maximum Filter Bypass Leakage (% of nominal flow rate)	≤1 (F8)	≤1 (F8)	≤1 (F8)	≤0.5 (F9)
5	Thermal Transmittance of casing	0.5<U≤1(W/m ² K) or 0.088<U≤0.176 (Btu/ft ² h°F) (T2)	0.5<U≤1(W/m ² K) or 0.088<U≤0.176 (Btu/ft ² h°F) (T2)	U ≤ 0.5(W/m ² K) or U ≤ 0.088 (Btu/ft ² h°F) (T1)	As per equipment data sheet
6	Thermal Bridging of casing	0.6 ≤ kb ≤ 0.75 (TB2)	0.6 ≤ kb ≤ 0.75 (TB2)	0.75 ≤ kb ≤ 1.0 TB1	As per equipment data sheet

C. Structure & Panels

AHU structure shall consist of extruded aluminum, with insulated double skin sheet metal panels. The metal shall have a minimum thickness of 0.7mm for the outer skin and 1mm for the inner skin & strengthened as necessary to prevent distortion and drumming. Ensure structure is rigid enough to prevent distortion during transportation and after final assembly on site. Seat panels into extruded frame with purpose made corner joints. Ensure framework is self supporting. For vertical units strengthen framework to support additional weight.

The insulation shall be a minimum thickness of 40mm or as indicated in the EQUIPMENT DATA SHEET. For outdoor mounted units and treated fresh air units the insulation thickness shall be a minimum of 50mm or as necessary to prevent condensation. The insulation shall be of the closed-cell foamed plastic type or mineral wool, or polyurethane, of suitable thickness & thermal conductivity to meet the Thermal Transmittance Standards specified earlier.

The panels shall be easily removable using quick release fasteners to obtain access for inspection and maintenance. All items shall be assembled by means of bolts, anti-vibration lock washers and nuts or accepted quick release fastenings.

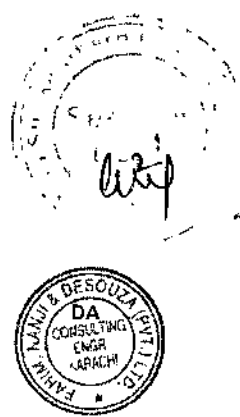

SPECIFICATIONS

PROJECT NO : 1890
PROJECT TITLE : SSGCL HEAD OFFICE BUILDING, KARACHI
DATED : 20TH APRIL, 2026

Construct unit to withstand maximum fan static pressure without plastic deformation.

Additional insulation shall be provided as required to prevent any risk of condensation on the external surfaces for units mounted outdoor or for treated fresh air handling units.

Outer skin material - Polyester epoxy coating to a thickness of 200 microns on galvanized steel with galvanising to a thickness of 20 microns to EN 10142 or EN 10143 and EN 10147.

Inner skin material - Zinc coated steel hot dip galvanized to a thickness of 20 microns to EN 10142 or EN 10143 and EN 10147.

Use corrosion resistant fastenings throughout. Do not use self tapping screws. Provide panel gaskets to give a durable seal between panels and frames to prevent excessive air leakage.

The casing strength of the assembled unit shall be designed to meet BS EN 1886, Class 2A. The casing air leakage of the assembled unit shall be designed to BS EN 1886, Class B.

The weighted sound reduction index (Rw) of the casing panels shall be greater than 28 dB when tested in accordance with ISO 140/3 and BS 5821 Part 1.

All units shall be mounted on appropriate anti-vibration mountings.

All AHU sections shall be mounted on a galvanised structural base, minimum 160mm high, extending to the full length of the air-handling unit. Jointing between sections shall be either by galvanised steel bolts or by galvanized steel cleats. Non-ageing rubberised material gasket shall be provided between the sections.

D. Volume Control Dampers

Control dampers shall be of extruded aluminum. Dampers shall be of the opposed blade multi-leaf type. Dampers shall have open-close indication sign. The arrangement of dampers shall ensure adequate mixing. Necessary brackets & linkages shall be available for motorized operation. The volume control dampers shall have synthetic seals on the blade tips and spring loaded side edge seals to ensure leakage rate does not exceed 1% of nominal flow at 250 Pa negative pressures.

E. Drift Eliminator

Where units incorporate humidifying plant and/or cooling coils, the AHU shall be provided with drift eliminators to reduce/eliminate transfer of water. Such AHU's shall have adequate drain trays to collect water; the drain trays shall be extended, or other means of collection shall be provided, to ensure the removal of any water deposited or condensed in adjacent sections. Trays collecting cooled water shall be made of stainless steel and shall be insulated by closed cell foam insulation to prevent condensation on the outer surface, and shall be provided with a trapped outlet to drain.

F. Access Doors

Provide access openings to fans, dampers, filters, cooling coils, humidifiers, etc. complete with opening devices, and sealed to prevent air leakage. Ensure seals are designed for normal maintenance operations for a minimum of 10 years.

Access doors shall be 400mm minimum width, hinged & removable type, preferably with universal mounting and not requiring any tools for opening the door. Hardware used shall be of high quality from a renowned manufacturer.



SPECIFICATIONS

PROJECT NO : 1890
PROJECT TITLE : SSGCL HEAD OFFICE BUILDING, KARACHI
DATED : 20TH APRIL, 2026

G. Accessories

1. Provide flexible connection between fan discharge and AHU casing outlet. Ensure flexible connections comply with fire regulations.
2. Provide Magnehelic Differential Pressure Gage across each filter set, to measure pressure drop across filters.
3. Provide inspection port-holes in all sections of the AHU.
4. Provide bulk-head mounted lights in all sections of the AHU, with operating switch mounted outside the AHU.
5. Provide terminal box on outside of the AHU, with wiring terminated between the terminal box and the motor. This shall also include ground wire.
6. Provide external Air-Handling Units with rain hood.

2.4 Fan & Motors

- A. Fans shall be either DWDI Centrifugal fans as specified in Section 23 34 16 or Plug Fans as specified in Section 23 34 17, as indicated in the EQUIPMENT DATA SHEET.
- B. Motors shall comply with specifications given in Section 23 05 13.
- C. Fan & Motor shall be mounted on a mounting base, isolated from casing with spring mounted vibration isolators. Motor mounting shall allow quick adjustment using jackscrew.
- D. Fans fitted to all air handling units shall be provided with external lubricators arranged to terminate adjacent to the access door to the fan section of the air handling unit.
- E. Fans shall be capable of giving the specified performance when tested in accordance with AMCA 210-85 and AMCA 300-85.
- F. Fans shall be capable of discharging the required volume of air against the ductwork system resistance plus the resistance through the unit itself. Contractor shall add the resistance through the unit to the external static pressure indicated for selecting the fans.
- G. For blow through units ensure air-flow in downstream sections of unit has relatively uniform velocity profile. If necessary, provide diffuser section.
- H. Supply fan guards to EN 292. Belt driven fans shall be fitted with pulleys suitable for V-belts; pulleys of the taper lock type may be used for drives up to 30 kW output. Alternatively, and in any case above 30 kW output, pulleys shall be secured to the fan and the motor shafts by keys fitted into machined keyways. Pulleys shall be keyed to the fan shaft in the overhung position. Keys shall be easily accessible so that they can be withdrawn or tightened and they shall be accurately fitted so that the gib head does not protrude beyond the end of the shaft.
- I. Machined bolts, nuts and washers only shall be used for the assembly of fans; all bearing surfaces for the heads of bolts or washers shall be counter faced. Holding-down bolts for fans and motors shall be square section under the head or be fitted with lugs to prevent them turning in the fan base plate when the nuts are tightened. Any fan which is too large or too heavy for safe manhandling shall be provided with eyebolts or other lifting facilities to enable mechanical lifting equipment to be used.
- J. Unless otherwise indicated centrifugal fans larger than 7.5 kW output shall be of the backward curved blade airfoil type having fan total efficiencies of not less than 78%. Below 7.5 kW fans may be either forward curved or backward curved type. Fan casings shall be constructed of mild steel plates with angle stiffeners and base angles to ensure freedom from drumming and shall be suitable for operation at the maximum static pressure of the system. Fan casings shall be constructed so that

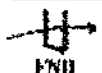

SPECIFICATIONS

PROJECT NO : 1890
PROJECT TITLE : SSGCL HEAD OFFICE BUILDING, KARACHI
DATED : 20TH APRIL, 2026

impellers can be easily withdrawn after installation. Outlets shall be flanged and inlets shall be flanged or spigotted as indicated except that for suction pressures greater than 1000 Pa inlets shall be flanged.

- K. A drain and plug shall be fitted to the fan casing at its lowest point.
- L. Impellers shall be of mild steel or aluminum, of riveted or welded construction, with spiders or hubs of robust design, and shall be capable of running continuously at ten percent in excess of normal speed. Impellers shall be keyed to a substantial mild steel shaft and the impeller with shaft shall be statically and dynamically balanced and tested for over speed before leaving the maker's works. Steel impellers shall be coated with minimum 60 micron epoxy painting.
- M. Shaft bearings of belt driven single inlet fans shall be truly aligned and rigidly mounted on a pedestal common to both bearings. Double inlet, double width fans shall have a pedestal mounted bearing at each side of the fan.
- N. All bearings shall be selected for at least 100,000 hours operation. Fan bearings shall be ring oiled sleeve bearings, or ball or roller type. Where silence is important the bearing pedestal shall not be attached to the fan casing, and ring oiled sleeve bearings shall be applied.
- O. Unless otherwise indicated centrifugal fans shall be driven by electric motors through V-belt drives. Belt tension adjustment arrangement shall be provided.
- P. Factory provided cable entry points shall be provided for the electrical cable connections to the motor.
- Q. Units up to and including 50 HP shall have variable pulleys and suitable for adjustments within +10% of specified RPM.
- R. The maximum fan outlet velocity shall be 10 m/s (2000ft/min).

2.5 Filter Section:

- A. Provide frames to allow withdrawal of filters. Low efficiency filters shall have slide withdrawal mechanism, while bag and HEPA filters shall have front mounting mechanism.
- B. Filters shall be provided in accordance with Section 23 41 10 Air Filters, and Section 23 41 33 High Efficiency Particulate Air Filters.
- C. The HEPA filters shall be provided with special mounting frames to allow easy mounting and removal of HEPA filters, and ensure that leakage rate is zero.
- D. Filter bypass leakage shall not exceed the specified standard.

2.6 Cooling / Heating Coil Section:

- A. Provide drain and vent connections to the coils brought outside the casing.
- B. Provide eliminator at the coil outlet for preventing carry over of water droplets.
- C. The Contractor shall ensure proper selection of all coils to provide required heat transfer capacity, and shall submit computerised selection data as proof of the same.
- D. Coil shall be removable from the unit without dismantling the entire unit. Provide slide rails to allow each coil section to be removed independently for access.
- E. The coil shall be of extended surface, staggered tube, and flat plate fin type. Coil arrangement shall be counter flow, multi-pass, and air face velocity on the coil shall not exceed 550 fpm (2.8m/s). Turbulators inside coils shall not be acceptable. Each coil shall be leak tested before shipment at 250psi (17.3 bars) and 220°F (105°C).



SPECIFICATIONS

PROJECT NO : 1890
PROJECT TITLE : SSGCL HEAD OFFICE BUILDING, KARACHI
DATED : 20TH APRIL, 2026

- F. Casing: shall be constructed of heavy-gauge galvanised steel with adequate diameter bolts holes for mounting. Coil side plates shall be of reinforced flange type.
- G. Tubes: shall be round seamless staggered copper tubes of $\frac{3}{8}$ " or $\frac{1}{2}$ " outer diameter. All joints shall be brazed with copper brazing alloys.
- H. Fins: shall be flat aluminium plate with full drawn collars to provide a continuous surface cover over the entire tube for maximum heat transfer. Bare copper tube shall not be visible between fins. Tubes shall be mechanically expanded into the fins to provide a continuous primary to secondary compression bond over the entire finned length for maximum heat transfer rates. Fin spacing shall not exceed 10 fpi (4 fins/cm).
- I. Headers: shall be of extra heavy seamless copper tubing. Tube holes shall be intruded to provide the maximum brazing surface for added strength. Header end caps shall be heavy gauge, die formed copper, with steel male pipe thread supply & return connections. Air vent shall be provided on the top of each header. Water-cooling coils shall be circuited for drainability and for service without removing individual plugs from each tube. Headers of cooling coil shall be outside the air stream and enclosed in an insulated box.
- J. Drain Pan: The drain pan shall be double skinned, fabricated of stainless steel to AISI 304, formed with the base of the AHU with a fall of at least 1:30 to ensure continuous drainage without any water retention in the drain pan. It shall have minimum 1 inch (25mm) thick insulation of polyurethane or closed cell foam. Provide threaded drain outlet from drain pan, sealed to the casing with neoprene gasket.
- K. When so indicated in the EQUIPMENT DATA SHEET, cooling coil shall be protected with anti-corrosive coating polyurethane coating with metallic emulsion to provide 3000 hours of salt spray protection as per ASTM B117.

2.7 Heat Recovery Devices:

- A. Rotary Heat Exchanger Refer Section 23 72 13.
- B. Plate Type Heat exchanger Refer Section 23 72 19.
- C. Heat Pipes Refer Section 23 72 35.

2.8 Hygienic Air-handling Units:

Air-handling Units specified to be "Hygienic Type" in the EQUIPMENT DATA SHEET, shall comply with relevant EU/DIN hygienic standards, and shall be provided with at least the following:

- A. Internal panel material shall be SS-304.
- B. All corners shall be rounded.
- C. Internal Surface and wall shall be smooth and with non-porous grooves.
- D. Seal and gap filling materials shall be non-porous and non-moisture absorbing.
- E. All parts and components of the unit, such as fans, motors, filters, coils (together with droplet separator and drain pan), etc. shall be resistant to commonly used cleaning and disinfecting agents.
- F. Fin spacing shall allow easy cleaning.
- G. All parts shall be easily accessible for disinfection purpose.
- H. Lights shall be marine type, with non-shatter proof material.
- I. Fans shall be preferably plug type, to avoid dirt of belts & pulleys.



SPECIFICATIONS

PROJECT NO : 1890
PROJECT TITLE : SSGCL HEAD OFFICE BUILDING, KARACHI
DATED : 20TH APRIL, 2026

- J. Ultra Violet Germicidal Irradiation (UVGI) Lamps shall be installed in front of the cooling coil, if so indicated in the EQUIPMENT DATA SHEET.
- K. Sound absorbers shall be acoustically transparent foil to act as moisture barrier and shall be covered with perforated SS304 sheets.

2.9 Walk-In Air Handling Units (Unit Height Higher than 1500mm):

- A. Ensure floor is double skin with internal framework to support weight of two men, tools and equipment.
- B. Provide weatherproof bulkhead luminaries and switches.
- C. Provide non-slip floor surface.
- D. Ensure insulation is protected.
- E. Ensure access doors can be operated from inside and outside.
- F. Provide walk ways in large units over 2m high.

2.10 External Air Handling Units:

Construct air handling units for external use with rain hood. Provide weatherproof isolator.

Where indicated provide connection for lightning protection.

2.11 Labeling:

All AHU sections shall be labeled to identify the components therein and their specification (i.e. filter grade, heat transfer rate (kW), electrical rating (kW), Flow rate (m³/s), Pressure drop/rise (Pa) etc.).

2.12 Spares:

Provide spares as indicated under EQUIPMENT DATA SHEET.

PART-3: EXECUTION

3.1 Examination:

Before ordering any materials/commencing work, verify that building structure associated with the system is within tolerance and take full account of shape configuration and material properties of the structure.

3.2 Preparation:

Provide flat level plinth for the AHU.

3.3 Handling & Storage:

Deliver AHU/sections to site, completely identified in accordance with shop and certified drawings prepared for this work. Store in accordance with manufacturer's instructions, above ground, properly protected from the weather and construction activities.

3.4 Fabrication:

All AHU's shall be fabricated in the manufacturer's works and delivered to site in sections.

3.5 Installation:

A. Pre Installation Check

1. Before beginning installation in any area, examine all parts of the adjoining work into which applicable work is to be placed. Should any conditions be



SPECIFICATIONS

PROJECT NO : 1890
PROJECT TITLE : SSGCL HEAD OFFICE BUILDING, KARACHI
DATED : 20TH APRIL, 2026

found which will prevent the proper execution of the work, installation shall not proceed in that area until such conditions are corrected by the contractor.

2. Ensure air handling units are positioned to allow adequate space for maintenance and access.
 3. Duct Connections: Ensure air stream is straightened as it leaves unit discharge. Ensure ductwork connection is long enough to preserve the aerodynamic performance of the fan.
- B. Services Connections**
1. Ensure panels are sealed around electrical cable and pipe work service entry points to prevent air leakage.
 2. Provide flexible cables between fan motor and local isolator.
- C. Isolation of Units**
1. Provide means of isolating air handling units electrically to allow maintenance and repairs to be carried out.
 2. Provide means of isolating pipe work to air handling units to allow maintenance and repairs to be carried out.
 3. Provide means of isolating steam to humidifier when access door is opened.
- D. Drainage of Free Water**
- Make provision for free water to be caught, collected and drained away. Provide U-traps on all drains suitable for the negative/positive pressure created by the fan.

3.6 Field Quality Control:

Provide field quality control according to the Contractor's approved Project Quality plan.

3.7 Cleaning:

- A. Refer Section 23 05 93.
- B. Remove labels after work is complete.
- C. Remove all splashed paint, cement splatter, protective paper, etc after work is complete, & deliver AHU in clean condition.

3.8 Protection of Finished Work:

Protect all equipment & work from deterioration from any condition, till handing over.

3.9 Foundation:

Foundation shall consist of minimum 100mm concrete pads constructed of 1:2:4 cement concrete. The foundation shall be finished with 5mm thick cement plaster, edges shall be provided with 25x25x3mm angle iron. The height of concrete pad shall be suitable for the height of drain trap for the particular AHU.

3.10 Installation:

The installation shall be carried out complete in all respects as per recommendations of the manufacturer & as specified herein. Pipe connections, duct connections, flexible connections, electrical connections, drain connections, etc., shall be done by the Contractor complete in all respects.

Provide drainage pipe work from cooling coils, humidifiers and components where water may collect. Comply with recommendations in CIBSE Technical Memorandum TM13 in connection with Legionnaires' disease. Provide traps suitable for the static pressure involved.

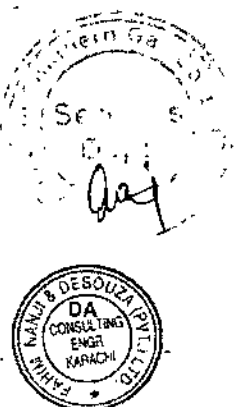

SPECIFICATIONS

PROJECT NO : 1890
PROJECT TITLE : SSGCL HEAD OFFICE BUILDING, KARACHI
DATED : 20TH APRIL, 2026

3.11 Commissioning & Testing:

The unit shall be commissioned and tested as per the manufacturer's recommendations. Drives shall be adjusted for the proper airflows, etc. The Contractor shall be required to carry out tests, on forms to be supplied later by the Engineer, and obtain approval.

END OF SECTION 23 73 10



SPECIFICATIONS

PROJECT NO : 1890
PROJECT TITLE : SSGCL HEAD OFFICE BUILDING, KARACHI
DATED : 20TH APRIL, 2026

FLOW BALANCING VALVES

1. Balancing & Shut Off Valves:

The balancing valve shall be furnished and installed where shown on drawings. Balancing valve shall be suitable for flow balancing, pressure differential read out and shut off. It shall have a locking arrangement at the balanced position, so that when used for shut off it will not open more than the balanced position.

Balancing valve shall be so selected that the pressure drop across the valve shall not exceed 6 kPa at full open position.

Upto Ø50mm the body shall be made of bronze with threaded connections suitable for 300 psig. Size Ø65mm and above shall be made of Cast Iron with flanged connections suitable for 240 psig.

Each balancing valve shall have self sealing readout nipples permanently connected to the valve for installation of a read out meter. At least one of the two readout nipples shall be provided with ball valve for drain and filling.

Each balancing valve shall have a calibrated scale for easy determination of valve position. It should be either on hand wheel or spindle. This calibrated scale shall be designed to indicate 1/10 portion of single turn of hand wheel.

Each balancing valve shall be constructed with internal spindle seals to prevent leakage around rotating part. Each balancing valve shall have a PTFE seal on disc to maintain tight shut off.

2. Balancing Meter:

Meter shall consist of differential pressure gauge and a micro computer which should be programmed to indicate direct reading of:

- ◆ Flow Rate
- ◆ Differential Pressure
- ◆ Flow Velocity
- ◆ Flow Temperature

The balancing Instrument shall have two main components:

- ◆ An instrument which contains a micro computer, input touch pad, LCD display and re-chargeable NiMh batteries.
- ◆ A sensor unit which contains a piezo-resistive pressure sensor, one measurement valve and connections. The measurement valve shall have a safety function which protects the sensor from too high differential pressure.

Balancing meter shall be suitable to operate at 240 + 10 volts/50Hz. Balancing meter shall be capable of transmitting data to BMS system.

3. Reference Specification:

The following specifications shall be construed to be part of these specifications.

- 23 05 01 – Basic Mechanical Requirement
- 23 05 02 – Basic Mechanical Materials and Methods
- 23 05 29 – Supports & Anchors
- 23 05 50 – Painting & Coating

END OF SECTION 23.86.20



SPECIFICATIONS

PROJECT NO : 1890
PROJECT TITLE : SSGCL HEAD OFFICE BUILDING, KARACHI
DATED : 20TH APRIL, 2026

AIR VENTS

1. Automatic Air Vents:

Automatic air vents shall be suitable for liquid systems. Body and cover shall be of malleable iron. Float & Valve seat shall be of stainless steel. Valve head shall be of Vitone (Synthetic Rubber). Connections shall be 13mm or 20mm as specified, screwed BSP. Vents shall be suitable for service upto 125 SWP (8.5 bars) & 250°F (120°C) service.

Vents shall be similar to model AE 550 manufactured by SPIRAX-SARCO.

Air vents shall be provided at all high points, on all water coils, and where shown on the drawings to ensure adequate venting of the piping system. A ball valve shall be provided to isolate the vent. The vent outlet shall be piped to a nearby convenient drain using suitable diameter flexible transparent PVC tubing.

2. Reference Specification:

The following specifications shall be construed to be part of these specifications.

- 22 05 01 - Basic Mechanical Requirement
- 22 05 02 - Basic Mechanical Materials and Methods
- 22 05 10 - Equipment Installation
- 22 05 11 - Pipe Welding
- 22 05 23 - Valves & Strainers
- 22 05 29 - Supports & Anchors
- 22 05 48 - Vibration Isolation Control
- 22 05 50 - Painting & Coating
- 22 05 53 - Mechanical Identification

END OF SECTION 23 86 35



SPECIFICATIONS

PROJECT NO : 1890
PROJECT TITLE : SSGCL HEAD OFFICE BUILDING, KARACHI
DATED : 20TH APRIL, 2026

MOTOR CONTROL CENTRES

1. General:

a) **Scope:** The Motor Control Centres works included in the scope of Mechanical Contract are shown on the drawings and given in these specifications. It shall include but not be limited to the following:

- ◆ Motor Control Centres (MCC's) & Starter Panels (SP's) for HVAC equipment.
- ◆ All outgoing power cables and earthing from MCC's and SP's to equipment.
- ◆ All control cables for the control system specified herein between MCC's, SP's, remote starters, push buttons, control devices, alarms, metering, relays, etc.
- ◆ Installation Materials and Accessories.
- ◆ Testing and Commissioning of system.
- ◆ Getting system approved by Electric Inspector.

The Contractor shall be responsible for providing within his bid price any additional equipment and/or make modifications in the electrical equipment/material to suit the requirement of the equipment offered by him for ensuring proper operation of the system as approved by the Engineer. Where stated on the drawings, the electrical power supply shall be provided by electrical contractor upto the incoming termination point in the MCC.

The MCC installation shall be as per MCC supplier recommendation and site installation requirement.

b) **Standard Conditions:** All equipment shall be designed to operate satisfactorily and continuously under the following conditions:

- ◆ Supply Voltage - 400/230 volts \pm 10% three phase, four wire
- ◆ Supply Frequency - 50 Hertz
- ◆ Ambient Temperature - 113 °F (45 °C) max.
- ◆ Standards
 - ◇ British Standard Specifications and Code of Practices.
 - ◇ Pakistan Standard Institution
 - ◇ IEE UK "Wiring Regulation for Electrical Installations".
- ◆ Ingress Protection Class - Indoor : IP40
Outdoor : IP54

c) **Rules & Regulations:** The Motor Control Centres installation works shall be carried out by a licensed Contractor, authorised to undertake such work under the provisions of the Electricity Act 1910 and the Electricity Rules 1937 as adopted and modified upto date by the Government of Pakistan.

The supplier shall be responsible for submitting test certificates and having the installation passed by the Government Electric Inspector. All requirements of the Electric Inspector and the Electric Supply Company shall be complied with.

d) **Equipment and Materials:** In the specifications, certain types and makes of equipment material have been specified only for the purpose of reference and guidance. Prior to procurement of the materials the supplier shall submit to the Engineers for approval, the names of the manufacturers and other technical data as required to satisfy as to the suitability, durability, quality and usefulness of the material intended to be purchased. When advised by the Engineer, samples of material shall be provided free of cost for approval. If the material or equipment offered under this



SPECIFICATIONS

PROJECT NO : 1890
PROJECT TITLE : SSGCL HEAD OFFICE BUILDING, KARACHI
DATED : 20TH APRIL, 2026

provision is, in the opinion of the Engineer, equal to or better than specified, it will be given consideration.

- e) **Drawings & Data to Be Furnished By The Contractor:** The drawings and data to be furnished by the Contractor for each electrical equipment shall include the following as applicable:

Shop drawings of MCC's and SP's showing dimensional plans, elevations, sections, line and wiring diagrams, foundation details, along with the relevant technical literature and manufacturer's characteristic data of proposed components. The Supplier shall also supply three copies of manufacturer's instruction manuals for the installation, operation and maintenance of the specified equipment including manuals of spare parts and tools of the equipment.

2. Tests:

- a) **Factory Test:** All routine tests on equipment shall be performed at the manufacturer's works in the presence of the Engineer or his representative prior to delivery of equipment. Test results and certificate shall be supplied in triplicate.

3. Control and Protection Equipment:

- a) **Motor Control Centres (MCC's):** The MCC shall be of 16 SWG sheet-steel, floor-mounted cubicle type, totally enclosed, splash-proof, dust tight and vermin proof to IP40. It shall be factory tested and complete in all respect with components, material and accessories, and finished according to the specifications.

The MCC Shall:

- ◆ have components with short circuit ratings to IEC 947-2, Icu/Ics at 415V (as noted on the MCC Equipment Data Sheet).
- ◆ be designed for flush mounting of all instruments on the front side.
- ◆ be designed for incoming and outgoing connections from the bottom or top as required, with removable top & bottom cover plates.
- ◆ have the components mounted in a logical sequence and arranged so as to facilitate operation and maintenance from the front only.
- ◆ have a separate cubicle for installation of digital temperature indicators and controllers required for automatic control.
- ◆ have 30.5mm push-button & LED lights, 96mm x 96mm meters, class 1.5 CTs, HRC control fuses.
- ◆ have engraved plastic nameplates for all circuits.
- ◆ The cabling inside the MCC shall be properly tagged (harnessed by means of straps or cords). All indicating, and control equipment shall be suitably arranged and clearly labelled with indelible labels indicating the ratings, circuit number, etc. All internal wiring shall have numbered ferrules at both ends for identification. Wiring to components on the door shall be made with flexible wires in flexible PVC pipe.

All metal work shall be cleaned down to bare shining metal, degreased, and then spray painted with:

- ◆ two base coats of anti-corrosive paint (zinc chromate/red-oxide).
- ◆ two finish enamel coat in approved colour – inside and outside.
- ◆ stove enamelled.
- ◆ be provided with ventilation ports suitably vermin proof.
- ◆ A power and controls circuit diagram shall be provided at a suitable location inside the MCC.



SPECIFICATIONS

PROJECT NO : 1890
PROJECT TITLE : SSGCL HEAD OFFICE BUILDING, KARACHI
DATED : 20TH APRIL, 2026

- b) **Outdoor Starter Panels:** shall be totally enclosed, weatherproof type. These shall be suitable for mounting on a galvanised steel or RCC pedestal. The front door shall be lockable hinged and gasketed for weather-proof and water tight design (IP54). The unit shall be suitable for outdoor duty under all local weather conditions and designed to allow for ventilation and cooling of the equipment.

All cable connections shall be from the bottom. Suitable cable gland with weather-proof sleeve for PVC insulated, PVC sheathed armoured or unarmoured cables for sizes shown on the drawing shall be provided. All live parts of the switch board shall be protected from the front to avoid any accidental contacts during operation. All indication lamps shall be visible from outside, while the operating switches and push buttons shall be accessible after opening of door. All internal wiring shall have numbered ferrules and shall be suitably strapped and supported.

Where bus bars are provided, these shall be of high conductivity electrolytic copper insulated by PVC covering for protection against weather.

The outdoor panels shall be minimum 14 SWG, 2.0mm sheet steel painted with two base coats of zinc-chromate/red-oxide paint and finished in two coats of heavy enamel paint stove enamelled inside and outside in colour as approved by the Engineers.

The approved danger sign, switch board designation, supply source, etc., shall be written on the front door in conspicuous letters, in red colour over white background. A power controls circuit diagram shall be provided inside the panel.

- c) **Indoor Starter Panels:** shall be wall or pedestal mounted depending on the location. These shall be fabricated from 14 SWG 2.0mm sheet steel, having hinged lockable door and finished in a manner as specified for MCC. All indication and control components shall be accessible from outside. The panels shall meet the other general requirements as stated for MCC.

Where pedestal is provided it shall be fabricated from galvanised steel members having all galvanised accessories. The mounting height of the panels shall be 1200mm when measured from the floor level to the bottom of the panel.

- d) **Controls:** to be provided for the various equipment are described below or in the MCC Equipment Data Sheet. These controls are the specific operational requirements of particular equipment, and shall be in addition to any other controls specified elsewhere, and shown on the drawings and/or normally required for proper operation and performance. All wiring, control equipment shall be furnished by the Contractor.

- i) "ON", "OFF" and "TRIP" indication lamps shall be provided for all motors (AHUs & EFs) on the Motor Control Centre.
- ii) For all motors connectors to the MCC provision shall be made for Hand-Off-Auto selector switch for selecting mode of operation of motors. Hand operation shall be through ON-OFF push buttons. For auto operation, the circuit shall be arranged for connection to external circuits for receiving switching command from a Building Management System (BMS).
- iii) An audible alarm shall be provided on the MCC which shall operate in case of tripping of motors or other alarm conditions related to the electrical system. Alarm "test, accept and reset" facilities shall be provided.
- iv) Lamp "push-to-test" facility shall be provided on MCC.
- v) Two spare changeover contacts shall be provided on each starter for Employees use.
- vi) Motors with winding embedded thermistor protection shall be provided with suitable relays in the MCC to trips starter if the motor over-heating.

- e) **Components:** The MCC's, indoor and outdoor panels shall be provided with all components as specified and shown on the drawings and as necessary for the satisfactory operation. Typical component specifications are given below.

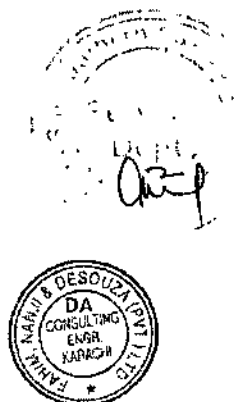

SPECIFICATIONS

PROJECT NO : 1890
PROJECT TITLE : SSGCL HEAD OFFICE BUILDING, KARACHI
DATED : 20TH APRIL, 2026

- i) Bus Bars shall be made of high conductivity electrolytic copper. The phase identification on bus bars shall be red, yellow and blue for phase, black for neutral and green for earth. The phase bus bars shall be of HDHC finned copper (99.9% purity) and insulated or properly painted with red, yellow, or blue and black colour coding identification sequence. If copper purity is less than 99.9% (up to 98.5%), then the correct density to be used shall be maximum 1.5A/mm² for loads upto 1000 A, maximum 1.2A/mm² for loads above 1000 A.
- ii) Circuit Breakers: shall be single/triple pole, air break, manually operated with front drive. ON-OFF-TRIPPED indication shall be provided on all circuit breakers. The circuit breakers shall have the following protections:
 - ◇ Three pole, temperature compensated thermal overload release, fixed type for starter panels and adjustable for all other circuits.
 - ◇ Indicating lamps also provided as shown on the MCC Equipment Data Sheet and also for control system as stated in the specifications. The incoming circuit breaker on MCC's shall be provided with under voltage/shunt relays. Suitable connections shall also be made to disconnect electric supply to HVAC system in case the Fire Alarm panel is activated.
 - ◇ The circuit breakers (with magnetic only trips for short-circuit protection of motor-starters) shall have suitable characteristics so as to avoid false tripping due to motor starting current. They shall be used as short-circuit protection devices for motor starters to IEC 947 & BS4941 Part 1 (Category "C").
 - ◇ All circuit breakers shall be rated for IEC 947-2, Icu/Ics at 415v.
- iii) Ammeters and Voltmeters: All meters shall be flush mounted moving iron, spring controlled. The front dimensions shall be 96 x 96mm. The meters shall have accuracy Class 1.5 fed through a current transformer. The ammeters and voltmeters shall have measuring range as indicated on the drawings. Ammeters installed on motor circuits shall have appropriate over-range (600% for DOL starters, and 200% for star-delta starters) for the motor starting current.
- iv) Current Transformers: Air cooled, ring type transformers (CT) shall be provided having transformation ratio as indicated on the drawings. The CTs shall be of suitable burden, saturation factor, and have accuracy class 1.0.
- v) Selector Switches: Ammeter and voltmeter selector switches shall be complete with front plate, grip handle, and R-Y-B and OFF positions for ammeters and RY-YB-BR-RN and OFF positions for voltmeter.
AUTO-OFF-MANUAL and pump priority selector switches shall be of similar design with suitable nameplate.
- vi) Load Break Switch: Triple pole (AC23) load-break switches of current rating as specified shall be provided complete with front drive grip handle and front plate.
These shall also be provided in water-proof boxes near equipment when motor is remotely located from the MCC, as a means of safety isolation.
- vii) HRC Fuses: HRC link-type (NH) fuses with time-lag characteristics of current ratings as specified, shall be provided complete with fuse bases, fuses etc. The fuses shall have a fusing factor as specified for class Q1 in accordance with BS 88.
- viii) Indicating Lamps & Push Buttons: Indicating lamps shall be suitable for flush mounting complete with bases, 250 volt incandescent lamps and shall have rosettes of suitable colour. Push buttons shall be of the momentary contact type, suitably colour coded. Diameter of these components shall be 30.5mm
- ix) Line up terminals: Line-up terminal units (SIEMENS 8WA type or approved equal) wherever provided for control or power circuits shall be suitable for voltage and size of conductors as indicated on the drawing.



SPECIFICATIONS

PROJECT NO : 1890
PROJECT TITLE : SSGCL HEAD OFFICE BUILDING, KARACHI
DATED : 20TH APRIL, 2026

- x) Three phase outlet: Socket outlet for three phase circuit shall be five pin (three phase, neutral and earth) and provided with matching plug. Interlocking shall prevent wrong connection between plug and socket.
- xi) Motor starters: Suitable starters shall be provided for motors as shown on the drawings. The rating of each starter component shall be selected keeping in view motor rating, starting current, operating characteristics, etc. All starters shall have a minimum life of 0.5 million operations (AC3). Each starter shall be wired for manual and/or automatic operation depending on the operational requirements. The over-load relays shall have protections against phase-failure/ single phasing.

Direct-on-line Starter (DOL): These shall be provided with momentary contact ON-OFF push buttons, and lights, magnetic contactors, manual/auto-reset, differential type thermal/electronic overload release, trip indication lamp and other circuit components and accessories.

Star-Delta Starters (S.D.): These shall be automatic-timer controlled, three-contact or type, and meeting the requirements as stated above for DOL starters.

Two Speed Motor Starters: The starters shall be designed for two speed motors, having provision for starting at high or low speed, and meeting the requirements as stated above for DOL starters.

- xii) VFD & Soft Starters shall be procured, installed & commissioned in the MCCs by MCC manufacturer.
- xiii) VFD's shall be protected by fuses installed on padlockable fuses switches in a separate compartment/door to allow:
- Live working on VFD.
 - Dead working on out of line of sight motor/equipment.
 - Three fuses shall be as per VFD manufacturer's recommendation.
- xiv) Soft Starters shall be protected by semi-conductor fuses for type 2 protection as per manufacturer recommendation.
- Additionally a padlockable MCCB or switch fuse shall be provided for motor branch circuit protection as per manufacturer recommendation.

4. Schedule of MCC's & SP's:

The schedule of MCC's & SP's is provided under EQUIPMENT DATA SHEET (Section-2).

5. Reference Specification:

The following specifications shall be construed to be part of these specifications.

- 23 05 01 - Basic Mechanical Requirement
- 23 05 02 - Basic Mechanical Materials and Methods
- 23 05 10 - Equipment Installation
- 23 05 29 - Supports & Anchors
- 23 05 50 - Painting & Coating
- 23 05 53 - Mechanical Identification

END OF SECTION 23 87 15



PROJECT NO : 1890
PROJECT TITLE : SSGCL HEAD OFFICE BUILDING, KARACHI
DATED : 20TH APRIL, 2026

VARIABLE FREQUENCY DRIVES

1. General:

The Variable Frequency Drives (VFD) shall be capable of converting 3-phase/1-phase (50Hz) AC voltage into a variable output voltage and frequency. The VFD shall also be capable to supply a full output voltage to the motor even at a continuous supply voltage $\pm 10\%$. VFD shall be able to control motors of different sizes connected in parallel, and it must be possible to stop a machine during operation without the risk of tripping and shall regulate all types of IEC standard motors without load reduction and without the motor temperature becoming higher than under normal mains operation.

The VFD shall have filters in the intermediate circuit to ensure that the 5th harmonic transmitted to the mains supply is limited to approx. 30%. It must comply with EMC and RFI requirements according to EN5501 (VDE0875).

2. Construction:

The Variable Frequency Drives shall be manufactured and tested in accordance with ISO9001 and BS5750, parts 1&2. The metal enclosure shall conform IP20 unless otherwise specified in the EQUIPMENT DATA SHEETS.

VFD shall be provided with software controlled ventilation fan.

3. Controls:

The control panel shall be detachable type and able to function 3 meters away from the VFD to ensure that it can be mounted in a central control panel and must comply with IP54. The VFD must have an integrated PID-regulator as standard to obtain closed loop control, with 0-10V, 1-5V, 4-20mA signals.

The VFD control system shall be able to accept minimum four (4) configurable digital inputs, two(2) analog inputs, and provide two(2) configurable relay output, two (2) configurable analog output, eight (8) fixed frequencies, two (2) ramp times for each acceleration and deceleration & shall have one standard RS 485 communication port. The RS 485 interface shall be able to operate with all common industry protocols such as BACnet or Lonworks protocol as specified.

4. Required Features:

The Variable Frequency Drives (VFD), (frequency speed controller, variable frequency speed controller, adjustable speed drive) shall have the following features:

- a) Input Frequency50Hz
- b) Output Frequency5 - 100Hz
- c) Output Voltage.....Input voltage (400V, 3 phase or 230V, 1 Phase)
- d) Minimum efficiency of VFD 95%
- e) Protections against (with indication)
 - i) Short-circuit: Phase-Phase
 - ii) Short-circuit: Phase-Earth
 - iii) Over-current } High-speed fuses
 - iv) Heat sink over temperature
 - v) Motor thermistor over temperature
 - vi) Over-voltage/under-voltage
 - vii) Single-phasing
 - viii) Motor stalled

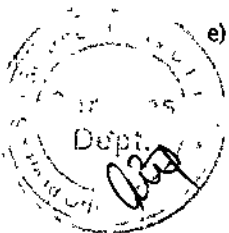

SPECIFICATIONS

PROJECT NO : 1890
PROJECT TITLE : SSGCL HEAD OFFICE BUILDING, KARACHI
DATED : 20TH APRIL, 2026

- ix) Motor over-speed
- x) Loss of set-point
- xi) Increase in dc link voltage due to braking of motor.
- f) Control.....By manual potentiometer or by external signal (4-20mA, 0-10V, serial communications port)
- g) Acceleration/Deceleration Time1-20 secs (separately adjustable)
- h) Overload Capacity.....1.5 x rated output current for 60 second.
2 x rated output current for 3 second.
- i) (current).....110% continuously

5. Standard Functions:

The VFD unit shall contain the following minimum standard functions:

- a) Inverter trip at 75°C on the heat sink.
- b) Protection against under-voltage.
- c) Protection against over-voltage.
- d) Alpha-numeric display (alpha-numeric code).
- e) Choice of language in display.
- f) 'ON', 'ALARM' indication.
- g) Choice of minimum 12 different displays, e.g. output current, voltage, frequency, speed, output, torque, motor temperature, energy kWh.
- h) The speed must be controllable via the keys (manual operation).
- i) Lock to prevent unintended programming of the VFD.
- j) 4 individual adjustable ramps-2 acceleration, 2 deceleration, with a setting range of 0-3, 600 sec.
- k) 4 setup menus.

6. Installation:

The Variable Frequency Drives shall be installed in accordance with manufacturer's recommendations complete in all respects.

Unless otherwise specified, the VFD along with its control panel shall be mounted on the Air Handling Unit (AHU). In this respect, the Contractor shall be responsible for co-ordination of the VFD supplier and AHU supplier to ensure that a proper space provision along with a passage for ventilation of VFD by its fan is kept in the AHU Plant Room.

7. Commissioning & Testing:

The VFD shall be commissioned and tested in accordance with ISO, BS and manufacturers recommendations. The test reports includes motor load test shall be submitted to the consultant for approval, along with technical operation and maintenance literature.

8. Spares:

The VFD shall be supplied with spares as indicated in the EQUIPMENT DATA SHEETS.

9. Reference Specification:

The following specifications shall be construed to be part of these specifications.

- 23 05 01 - Basic Mechanical Requirement
- 23 05 02 - Basic Mechanical Materials and Methods



SPECIFICATIONS

PROJECT NO : 1890
PROJECT TITLE : SSGCL HEAD OFFICE BUILDING, KARACHI
DATED : 20TH APRIL, 2026

- 23 05 10 - Equipment Installation
- 23 05 29 - Supports & Anchors
- 23 05 50 - Painting & Coating
- 23 05 53 - Mechanical Identification

END OF SECTION 23 87 20



SPECIFICATIONS

PROJECT NO : 1890
PROJECT TITLE : SSGCL HEAD OFFICE BUILDING, KARACHI
DATED : 20TH APRIL, 2026

TOOLS & INSTRUMENTS (ELECTRIC CHILLERS)

1. Instrumentation:

S. No.	ITEM DESCRIPTION	QTY.
1.	Moulded plastic manometer, accurate to 3%, range 0-3 inches water column, accessories to include 8 ft flexible double column plastic tubing, 2 connector fittings for 1/2" pipe thread (or) sheet metal ducts, 2 mounting screws & 3/4 oz. Bottle gage oil	1 No.
2.	Sling psychrometer complete with six replacement wicks & instructions & slide for RH calibration. Range: 20°F to 120°F, RH 10% to 100% on slide	1 No.
3.	Digital temperature indicator, 4 digit LED, 2" high display, complete with probe. Range 0 to 1600°F	1 No.
4.	Clamp on Ammeter with six ranges 0-5, 0-10, 0-25, 0-50, 0-100, and 0-250 amp readily facility. Industrial grade Japanese make	1 No.
5.	Digital multimeter for voltage, current & resistance ranges. Industrial grade Japanese make	1 No.
6.	Megger (Insulation Tester)	1 No.
7.	Alnor Velometer model Compu-Flow 5865	1 No.
8.	Fin Brushes each with plastic handle & six different size brushes	6 Nos.
9.	Electronic gas leak detector to detect gas concentrations upto 25ppm. Complete with battery charger and case	1 No.
10.	Laboratory glass thermometer — range 0-100°F	3 Nos.
11.	Laboratory glass thermometer — range 30°F to 120°F	3 Nos.
12.	Master pressure gages — 0-150 psi	1 No.
13.	Refrigerant charging gage manifold	1 No.

2. Tools:

S. No.	ITEM DESCRIPTION	QTY.
a.	Set of Screw Driver (flat Head) 2 sets with plastic handles (10 Nos. per set)	2 Sets
b.	Set of Screw Drivers (Phillips Head) with plastic handles (10 Nos.)	2 Sets
c.	Set of fixed spanners (10 Nos. per set)	2 Sets
d.	Set of adjustable spanners (6 Nos. per set)	2 Sets
e.	Set of pliers	2 Sets
f.	Set of hammers (4 Nos.)	2 Sets
g.	Hack saw with blades	2 Sets
h.	Testers, wire-strippers & other small tools	4 Sets

END OF SECTION 23 89 10



(Handwritten signature and stamp)

SPECIFICATIONS

PROJECT NO : 1890
PROJECT TITLE : SSGCL HEAD OFFICE BUILDING, KARACHI
DATED : 20TH APRIL, 2026

WIRES & CABLES

1. LV Cables

The LV cables, to BS 6346 and IEC 60502, shall be 1-core or 3-core or 4-core or 3.5 core (4-core with reduced neutral), compacted stranded copper or aluminium conductor, PVC or XLPE, with special sheaths insulated, as required, laid up with suitable fillers to make a circular shape. Where required, the cable shall be galvanised steel wire armoured over an extruded PVC bedding and provided with an overall special black PVC sheath. The voltage rating shall be 600/1000V, and the cores shall be colour-coded. The size, specification, and make of the cable shall be embossed on the sheath at 0.5 metre intervals (maximum).

2. Building Wire and Cable

Cable and conductors shall be PVC or XLPE insulated, with PVC sheaths, as required with copper conductors, single/multicore, 600/1000-volt grade for light and socket circuits and 600/1000-volt grade for motor and power circuits also, to BS 6004 & BS 6346 and IEC 60502.

The neutral and phase conductors shall be coloured black and red/yellow/ blue respectively. The circuit protective conductors shall be of hard drawn stranded bare electrolytic copper above the size of 6mm² (12 SWG), with a green/yellow sleeve at terminations, and for 6mm² and below a green/yellow PVC insulated conductor shall be used. For isolated earthing of data/computer systems, a cream coloured PVC insulated conductor shall be used.

3. Internal Cable Installation

In general, installation work shall be in accordance with the manufacturer's recommendations and IEE Regulations.

Each circuit shall have its own separate neutral, and the "looping in" system for wiring shall be used. Joints shall be made at main switches, distribution boards and panels, socket outlets, light and fan points and switch boxes only; no joints shall be made in joint boxes, nor will any "through joints" be allowed.

PVC/PVC 3-core flexible cords, shall be used for connection to the luminaries and fixtures from the ceiling rose/outlet box, through 3-terminal Polyethylene terminal blocks complying to BS EN 60998. Soldered or crimped tinned copper lugs, shall be used on the termination of cables and conductors 10mm² and larger. All multi-core cables shall be provided with compression glands, of the correct size and type, at panel entry positions.

Power cables shall be installed on walls/structure, on cable trays, in cable ducts, and in underfloor cable trenches. All installation material and fixing accessories such as spacers, clamps, saddies, brackets, glands, lugs, pins, nuts, bolts, plugs, cable ties, insulation tape, heat shrinks etc. shall be provided by the Contractor without additional cost.



Polyethylene terminal blocks



Cable ties



Fahim, Nanji & deSouza (Pvt.) Ltd
Consulting Engineers

Wire & Cables
Section 26 05 19

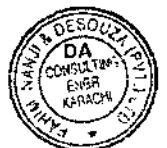

SPECIFICATIONS

PROJECT NO : 1890
PROJECT TITLE : SSGCL HEAD OFFICE BUILDING, KARACHI
DATED : 20TH APRIL, 2026

Vertical cable must be clamped to cable tray/ladder with metal cleats.

Single and multi-core cables in conduit and pipe shall be pulled after the entire raceway system has been completed, dried out, and cleared of all obstructions, using a wire brush and cutting mandrel.

The cables shall be installed on the surface of walls/structure by using heavy duty spacer saddles and clamps at intervals in accordance with IEE Regulations. The saddles and clamps shall be made of cast-iron or steel

(hospital-type) of approved design. Line up saddles and clamps shall be used where more cables than one are to be installed. The saddles shall be fixed to the wall/structure by means of nylon plugs and steel bolts.

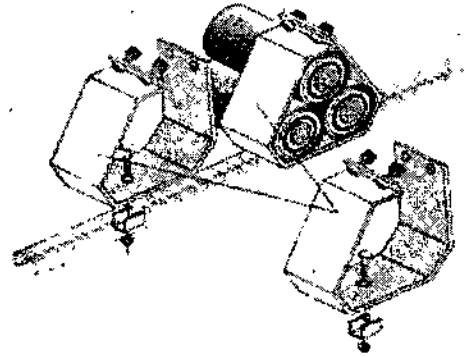

Cable cleats

The cables installed in the under-floor trenches shall be laid in single tier, when laid on the bed of the trench. Cables shall also be clamped on the walls of the trench by means of heavy spacer saddles and clamps of insulated material, or fixed on brackets grouted into the side of the trench, at maximum of 600mm intervals. The centre to centre distances between cables shall be equal to twice the diameter of the cable (75mm minimum and 150mm maximum). All cables shall be spaced at least 25mm from trench walls.

Cables installed on cable trays/ladders shall be pulled over shave pulleys installed on temporary brackets. The cables shall be spaced apart at distances equal to twice their overall diameter, and tied down with straps or cord. Cables in trunking shall be tied on circuits.

4. External Cable Installation

In general, the installation of external cables shall be carried out in accordance with the manufacturer's recommendations and IEE Regulations. The bending radius (as a multiple of the overall cable diameter, d_o) shall not be less than

600/1000V XLPE or PVC cable	12 d_o
8700/15000V XLPE cable	15 d_o

even during handling, pulling, and installation. A total maximum of 5% of the cable length shall be provided as slack (at termination positions, in draw-pits, etc.).

Cables shall generally be laid parallel to roads and foot paths, within the appropriate services reservations. During excavation, laying and backfilling, the adjacent and intersecting service pipes and runs shall not be damaged or disturbed.

Cable drums shall be carried on suitable trailers and unloaded near point of use. Any rolling shall only be in the direction of the arrow marked on the drum. If hoisting equipment is not available, ramp boards (max 1:4) with a winch or a coil of rope around the drum shall be used. The cable shall be laid out by jacking/propping the drum on an axle/spindle, and a braking plank installed below. Care shall be taken to see that the manufacturer's recommended pulling tension is not exceeded. Cable rollers shall be installed at maximum 2m spacing (1.2m for heavy cables) and at bends. A cable stocking or pulling eye shall be attached to the leading edge of the cable for pulling purposes. Cables shall not be laid if the temperature is below 0°C.

The following methods shall be employed for laying cables.

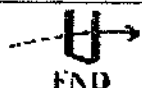

SPECIFICATIONS

PROJECT NO : 1890
PROJECT TITLE : SSGCL HEAD OFFICE BUILDING, KARACHI
DATED : 20TH APRIL, 2026

- i) Laying out from a trailer
- ii) Laying by hand
- iii) Laying by motor-driven rollers
- iv) Pulling by winches

If cable is to be carried by hand (un-supported by rollers), men shall stand 4 to 6m apart along the route. Flaking of cables ("figure-eight method") may be employed, taking care to prevent infringement of the minimum bending radius requirement.

Directly buried cables & raceways shall be laid with the minimum cover shown below:

Type of Cable/Raceway	In Open Ground and Under Pavement (mm)	Under Road Way (mm)
MV Cable	800	1000
LV Cable	600	800
Communication Cable	600	800
RCC Pipe	550	600
Communication Duct	300	500
PVC pipe	600	-

For directly buried cable, excavation shall be carried out in accordance with BS6031, and shall be kept free of water and protected against damage or collapse. Before cables are laid, the bottom of the trench shall be graded evenly, cleared of loose stones, and then covered for the full width of the trench with 75mm thick fine riddled-soil/sieved-sand bedding (in compacted 50mm layers). After cables are laid, a 50mm thick sand cover shall be laid over the cable, with 50mm thick protective bricks/tiles provided along the entire length. The first layer of back fill shall be placed manually and compacted by hand punning until a thickness of 150mm over the cover tile is reached. Additional layers shall be laid in 150mm increments and may be compacted mechanically.

When cable trenches are opened all cables shall be laid as quickly as possible. The Engineer's approval shall be obtained before a trench is back filled, but generally backfilling shall be commenced within 24 hours of cable laying and the work completed speedily. The minimum spacing between cables of various types shall be as shown below:

Type of Cable	MV (mm)	LV (mm)	Communication (mm)	Equipment, Pipe Work etc. (mm)
MV	50	300	300	300
LV	300	25	150	300
Communication	300	150	50	200

Multi-core cables in pipe and duct shall be pulled after the entire raceway system has been completed, dried out, and cleared of all obstructions, using a wooden mandrel (300mm length, dia 10mm less than pipe dia) to ensure correct alignment.

After installation of cables in underground ducts and pipes, the cable shall be supported from the bottom end of the pipe and the pipe ends shall be properly plugged and sealed to prevent ingress of water or vermin.

Underfloor cable trenches shall be constructed by others. All installation materials and fixing accessories such as hangers, spacers, clamps, saddles, brackets, brass compression glands, lugs, pins, nuts, bolts, plugs, cable ties, insulation tape, heat shrinks, etc. shall be provided by the Contractor without additional cost.

On completion of laying, terminating, and jointing of the cables and CPCs, a plan (1:500) shall be prepared, containing the following details:

Depi
Asif



SPECIFICATIONS

PROJECT NO : 1890
PROJECT TITLE : SSGCL HEAD OFFICE BUILDING, KARACHI
DATED : 20TH APRIL, 2026

- i) Type of cables, X-sectional area of conductors, rated voltage.
- ii) Year of manufacture, month and year of laying.
- iii) Actual laid lengths between centres of the joints, and between them and the sealing ends.
- iv) Exact locations and depths of cables and joints in relation to fixed points.

The electrical values of the completed installation shall be measured and recorded:

- i) Insulation resistance between conductors and between conductors and earth/armour.
- ii) Conductor resistance, using a suitable measuring bridge, of all cores.
- iii) Capacitance between conductors and between conductors and earth/ armour.

5. Cable Terminations & Joints

Cable terminations, joints and accessories shall meet with the cable manufacturer's approval, and work shall be carried out by specialists who are fully qualified and competent.

The cable ends shall be kept properly sealed with heat-shrink caps until jointing or termination work commences. Joints and terminations shall be of the outdoor or indoor type, as required.

Conductor connections and terminations shall be made with compression ferrules and lugs/crimp terminals, to BS 91 using a hydraulic crimping tool (with a complete set of dies) capable of high pressures.

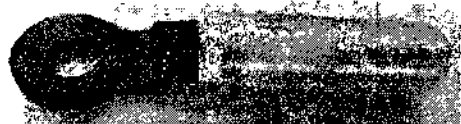

Cable lug

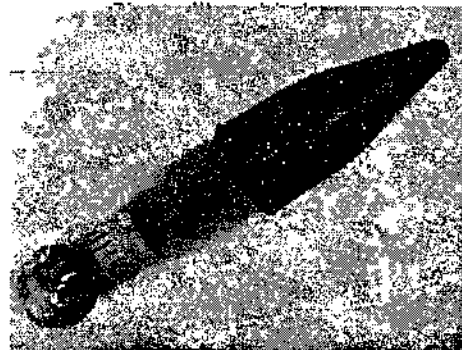

Cable entries into panels shall be made with brass nickel plated gland, to BS 6121 pt. 1:2005, of the correct sizes and types, to ensure proper support and sealing of the cable, and good earthing of the armour/braiding.

All cable lug terminations shall be sealed using heat shrink sleeve complying to EN 12068 to prevent the ingress of moisture or dirt at the junction between the insulation end and the back of the cable lug.

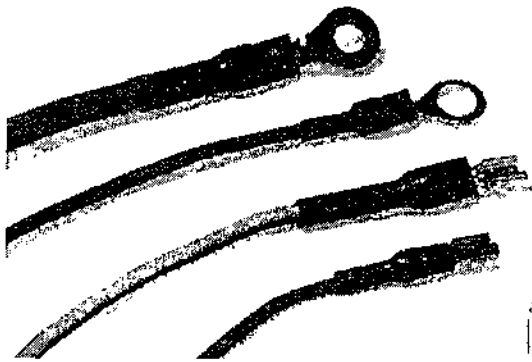

Heat shrink tubing over cable lug

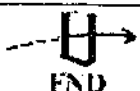
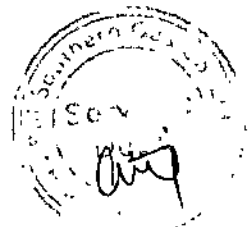

SPECIFICATIONS

PROJECT NO : 1890
PROJECT TITLE : SSGCL HEAD OFFICE BUILDING, KARACHI
DATED : 20TH APRIL, 2026

6. Cable Labels/Markers

The cable markers shall be located at every point where a cable enters a building, sub-station, plinth or feeder-pillar, at each joint, and along the route of the cable at intervals not exceeding 45m.

All cables/wires shall be properly labelled inside at both terminations ends. The labelling shall be as per electrical engineering practice and of rugged industrial grade materials, manufactured by reputable cable accessory manufacturers complying with EN 60204.

Each phase, neutral and earth conductor cable shall be labelled. The labelling shall be consistent with labels on following shop/as-built documentation submitted by contractor:

- ✓ layout drawings,
- ✓ circuit label schedules pasted inside each panel
- ✓ and cable schedules

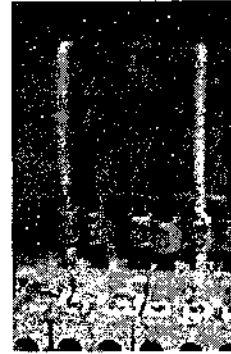

Cable Labels/Markers

Cable markers shall be made of concrete, 600mm square by 100mm thick with impressed characters. They shall be made of grade 20 concrete, as defined in CP110, with 10mm aggregate. The wording shall be "MV CABLE", "LV CABLE" or "COMMUNICATIONS CABLE" as appropriate, together with circuit details, as instructed by the Engineer; In addition, the word "JOINT" shall be added where appropriate.

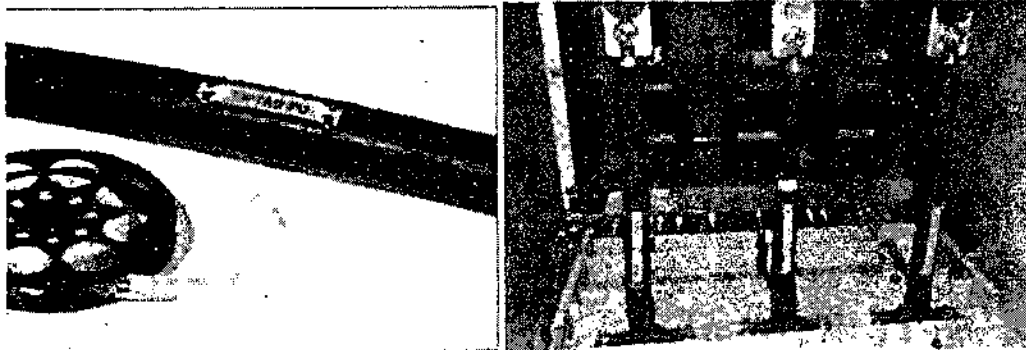

The cable markers shall be installed flush with the finished ground level on the precise line of the cable.

The cable markers shall be located at every point where a cable enters a building, sub-station, plinth or feeder-pillar, at each joint, and along the route of the cable at intervals not exceeding 45m.

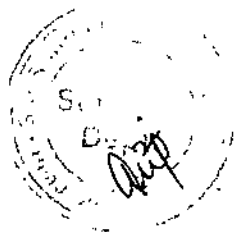

SPECIFICATIONS

PROJECT NO : 1890
PROJECT TITLE : SSGCL HEAD OFFICE BUILDING, KARACHI
DATED : 20TH APRIL, 2026

7. Cable Cleats

Single core cables (in trefoil) and multi-core cables on cable tray/ladder shall be clamped with cable cleats in accordance with IEC 61914. The spacing between the cleats shall be not more than 900mm. These shall be provided only if explicitly stated in BOQ.

A sample picture showing cable cleats is given below for reference.

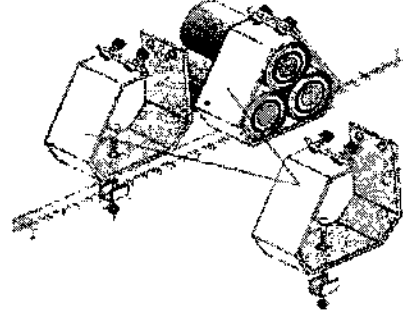
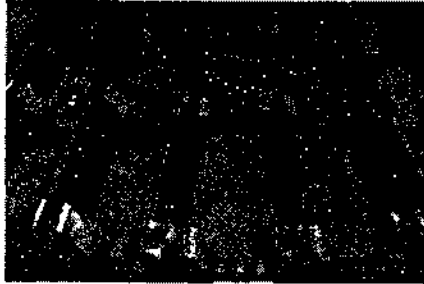

Cable cleats

8. Installation Guideline for Aluminium Cables

Use proper stripping tools to avoid damage to the individual conductor wires during stripping. Smoothly remove the sheath and the separator tape, (foil between conductor and insulation) over the entire length of the conductor.

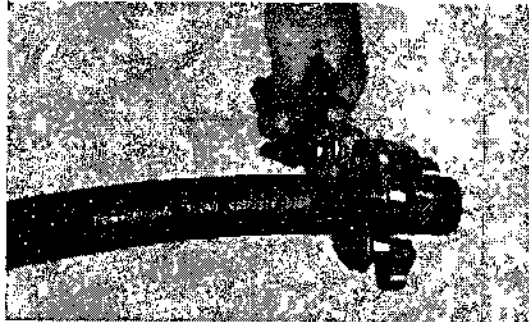

When aluminium and copper are exposed to air, it is covered by an oxide layer. The oxide layer on aluminium has hard outer layer and fixes strongly to the aluminium. Whereas the oxide layer on copper is relatively soft and conductive. Due to high resistance, remove the oxide layer.



a

After cleaning the film from the aluminium, immediately apply a special paste. The paste is an oxide breaker and prevents the formation of an insulating aluminium oxide coating on both the conductor and cable lug surfaces and decreases the contact resistance.

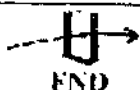

SPECIFICATIONS

PROJECT NO : 1890
PROJECT TITLE : SSGCL HEAD OFFICE BUILDING, KARACHI
DATED : 20TH APRIL, 2026

Place the crimp barrel of the bimetal cable lug over the stripped conductor end. Ensure that all wires of the conductor are within the crimp barrel. In order to ensure optimal mechanical and electrical contact the barrel of the cable lug is physically compressed around the conductor. Crimp the bimetal connection correctly to avoid open circuit and/or arcing problems.



When the bimetal lug has been crimped onto the conductor a heat shrink sleeve should be applied. The heat shrink sleeve shall contain glue, which melts and creates a seal when heated.

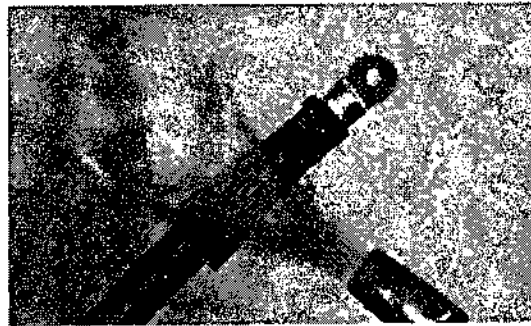

Handwritten signature and stamp

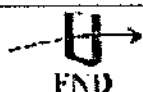

SPECIFICATIONS

PROJECT NO : 1890
PROJECT TITLE : SSGCL HEAD OFFICE BUILDING, KARACHI
DATED : 20TH APRIL, 2026

RACEWAYS/BOXES

1. General

Cable trays of different types shall be utilised as per area -site requirements. These shall be as follows:

a) Perforated cable tray

Where required, PVC sheathed wiring shall be run in admiralty pattern perforated (with holes over at least 30% of the plan area) hot-dipped galvanised (after fabrication) or pre galvanised(GI) cable tray of the specified gauge to BS 4678/NEMA, supported with HDGAF hangers, galvanised steel guy wires, or heavy-duty brackets at 1.2m intervals.

Where required, wiring shall be run on hot-dipped galvanised (after fabrication) cable ladders, to BS4678/1499/NEMA fabricated from welded sheet steel, in 2.44 minimum lengths, with slotted rungs.

Provisions shall be made in each section for strapping the cables, clamping circuit protective conductors, and having slip fit, interlocking connector couplings.

Suspension and support from the structure at 1.2m maximum intervals, shall be mechanically adequate for the weight of the cables. No welding to the structure shall be permitted. Factory made connectors shall be used at joints.

Bonding links shall be provided at each joint and secured by screws, nuts and shockproof washers. The bonding links shall make contact with the metal of the trunking or fitting, and continuity shall not depend on contact through the screws, nor on removal on site of paint finish from ferrous metal.

For vertical cables covers shall be clamped at intervals not exceeding with 1.5 meters with hot dip galvanised flat clamps.

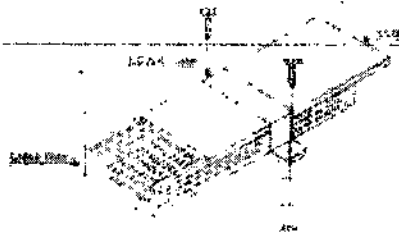

b) Cable Trunking

Where required, wiring shall be run in hot-dipped galvanised (after fabrication) sheet steel cable trunking of the specified gauge complete with all fittings and accessories, manufactured and installed in accordance with BS 4678/NEMA. The trunking shall be constructed with return flanges. Trunking covers shall be secured by anchored turn-buttons and locking bars, and minimum length of individual sections shall be 2.44m. The trunking shall be suspended/supported from the structure at maximum 1.2m intervals with straps and hangers fabricated from HDGAF. Conduit drops from the trunking shall also be supported with hangers. Factory made connectors shall be used at joints.

Junctions (tee and 4-way) in multi-compartment trunking shall be double depth to avoid reduction in cabling space. Cables in vertical runs shall be supported by pin racks, prongs, or bridging pieces. Fire barriers shall be provided at each floor level. Allowance for expansion shall be incorporated.

Bonding links shall be provided at each joint and secured by screws, nuts and shockproof washers. The bonding links shall make contact with the metal of the trunking or fitting, and continuity shall not depend on contact through the screws, nor on removal on site of paint finish from ferrous metal.

Where required, wiring shall be run in screened floor or surface uPVC trunking as specified, complete with all fittings and accessories, manufactured and installed in accordance with BS 4678.



SPECIFICATIONS

PROJECT NO : 1890
PROJECT TITLE : SSGCL HEAD OFFICE BUILDING, KARACHI
DATED : 20TH APRIL, 2026

2. Conduit

The Engineer drawings shall not show conduit routes and all the planning for arranging conduit routes shall be carried out by the Contractor to the satisfaction of the Engineer and submitted vide his shop drawing. He shall coordinate the routes with other trade contractors and after sign off /agreements carry out the installation works

The entire conduit system shall be essentially completed before the wire pulling is taken in hand. Each conduit run shall be tested for continuity and obstructions. All obstructions shall be cleared in an approved manner. Water and moisture that has entered any section of the conduit installation must be dried with suitable swabs to the satisfaction of the Engineer.

Adequate expansion joints shall be provided in all conduit runs passing across the expansion joints in concrete slabs of the buildings.

Pull boxes shall be installed in conduit runs at intervals mentioned below to facilitate die pulling length or wires: -

- | | |
|------------------------------------|-----------|
| i) Straight runs | 20 meters |
| ii) Runs with one 90 degree Bends | 15 meters |
| iii) Runs with two 90 degree Bends | 10 meters |

The minimum length of inspection/pull boxes should be four times the cable manufacturer's recommended bending radius of the cable.

All multiple runs of conduit shall be arranged symmetrically.

Exposed runs of conduit where required shall be firmly fixed by means of hospital type saddles, clamps and brackets etc. to the surfaces of walls, columns and ceiling. Rawal plugs or Phil plugs may be used for fixing saddles, clamps and brackets etc.

The spacing between two saddles may not be more than 30". The straight runs on walls may be 18" to 24" below the ceiling and in the event of any obstruction one to beams the reins may be routed around them. The conduit shall have a minimum clearance of 6 mm from the surface supporting it. Purpose made special clips and brackets may be required at some situations to support the conduit.

No conduit less than 25mm dia for Wiring. The size of conduit shall however be determined from the number of wires required in the conduit runs according to number of wires allowed as per IEE Regulations.

PVC conduit

Where required, wiring shall be carried out in electrical grade rigid PVC conduit, to BS 4607/6099, minimum 20mm dia, clipped to the surface with heavy, enamelled metal spacer bar saddles, at intervals specified in the IEE Regulations (rawl plugs and 32mm minimum length screws shall be used for fixing the saddles), or concealed in the structure with at least 38mm of concrete cover.

Flexible PVC conduit with appropriate glands shall be used for terminating all connections to recessed lighting fixtures in false-ceiling.

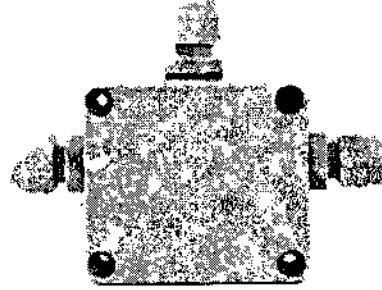

SPECIFICATIONS

PROJECT NO : 1890
PROJECT TITLE : SSGCL HEAD OFFICE BUILDING, KARACHI
DATED : 20TH APRIL, 2026

Junction boxes used for PVC conduiting shall be of IP 44, Polypropylene, glass-fibre reinforced, with IP 44 PVC glands for cable entry and exit and terminal fixing arrangements.

No round or locally manufactured PVC boxes are allowed

Steel conduit

Where required, wiring shall be carried out in heavy gauge (1.6mm minimum wall thickness, Class B) screwed steel conduit, to BS 31, minimum 20mm dia, protected (Medium, Class 2) with two coats of red oxide anti-corrosion primer and two coats of stoving enamel, clipped to the surface.

Conduit accessories, to BS 31, shall be cast-iron or of 16 b.g sheet steel, with protective treatment as above. Conduit terminations shall be provided with soft, rounded, brass bushes and lock nuts. Saddles shall be of the heavy-duty hospital-type, and shall be installed at spaces recommended by the IEE Regulations. Additional supports in the form of 40mm x 3mm flats or 40mm x 40mm x 3mm angle iron shall be provided wherever necessary. No welding to the structure shall be permitted. Flexible steel conduit shall be used with appropriate glands for terminating all connections to security/fire alarm equipment in false ceiling.

Galvanised conduit

Where required, external wiring shall be carried out in extra light-quality hot-dip galvanised steel pipe, to BS 137, minimum 15mm dia, installed as above. All accessories (bends, sockets, reducers, couplers, checknuts, etc.) shall also be galvanised.

Flexible steel conduit, to BS 731/6099, shall be used for final connections to motors and other equipment subject to vibration and movement. The flexible conduit shall be encased in water-proof plastic, retained with jubilee-clips. Ends of the conduit shall be welded to brass couplers/adapters.

Underfloor runs of conduits shall have at least 50mm of concrete cover, and be well sealed against the ingress of moisture.

3. Under Floor Ducts

Where required, cabling shall be laid in reinforced cement concrete pipes to ASTM C-14/C-76, with bores that are smooth and entirely free from rough spots, sharp edges, imperfections, and protuberances. The pipes shall be installed minimum 600mm below grade, with 75mm thick fine riddled-soil/sieved sand bedding under and 50mm thick cover over the pipe. Joints in pipe shall be made by wrapping one lap of a tarred gasket around the spigot of one pipe and placing it into the collar of the other pipe. The joint shall be filled with cement-sand (1:1) mortar.

Where required, cables shall be run in communication cable duct of overall size 300 x 300mm, provided with 4 Nos 100mm dia hollow openings with chamfered edges. It shall be precast with fair face surface and constructed with class 'B' reinforced cement concrete (1:1.5:3) well cured. The openings shall be smooth and free of any burrs or sharp edges. The internal diameter of the openings, shall not vary more than + 1.5 percent from the designed diameter. The wall thickness shall not be less than that shown in the design by more than 5 percent or 5mm whichever is greater. The cable ducts shall be rejected on account of fracture, cracks passing through the wall, defects that indicate imperfect proportioning, mixing, mouldings, surface defects indicating honey-combing or open texture, damaged ends, where such damage would prevent making satisfactory joint. The cable duct shall be as per PTC specifications and requirements, and laid with bedding and cover as detailed above.

Where required, communications systems wiring shall be run in PVC pipe (Class D or E), to BS 3505, buried 600mm below grade, with 75mm thick fine riddled-soil/sieved sand bedding



SPECIFICATIONS

PROJECT NO : 1890
PROJECT TITLE : SSGCL HEAD OFFICE BUILDING, KARACHI
DATED : 20TH APRIL, 2026

under, and 50mm thick cover over the pipe. The whole shall be covered with protective bricks before backfilling.

RCC draw-pits shall be constructed as per drawing to facilitate the pulling of cables. Size and locations of the pits shall take into account minimum bending radius of installed cables, nature of the site, and locations of other services. Draw-pit covers shall be load-bearing RCC, sealed with a sand-cement (1:1) mortar.

Raceway runs shall be neatly and symmetrically laid out, with at least 150mm clearance from other service pipes, with pull boxes at not greater than 10m intervals. No sharp bends or tees shall be used. The entire conduit system shall be completed before wiring is installed. Conduits shall be tested for continuity, and obstructions cleared by use of a cutting material or other approved device, and cleaned out before commencing the installation of wires

4. Boxes

Surface junction boxes for conduits

Surface mounted boxes containing terminals inside buildings shall be of IP44 Class

However, buried in ground or outdoor exposed must be IP 67 grade.

Surface boxes for outlets

These shall be manufacturer supplied and purpose built for surface mounted fixture-outlet.

concealed junction boxes for outlets

Outlet boxes, pull boxes, inspection boxes, switch and socket outlet boxes, fan regulator boxes, etc., to BS 4662, shall be of 18-gauge sheet steel, derusted, degreased, rust-proofed with two coats of zinc chromate primer and powder-coat finished, complete with earthing terminal.

All boxes shall have ample wiring space, and boxes used outdoors shall be weather-proof.

Alternatively, boxes shall be constructed of 18-gauge galvanised sheet steel, bent and fumed.

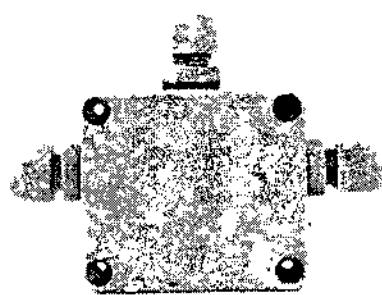

a) labelling:

Each system component shall have a designation according to IEC 61346 and should be labelled with the designation and clear text marking with the object name

Example for a central unit in the fire alarm system:



Where:

= stands for designation with functional aspect

H1 stands for Fire Alarm System

K100 stands for Control Unit no: 100

Each detector shall be labelled with its respective address in the Fire Alarm System so that the labelling corresponds with the text presented in the Fire Alarm Control panels



SPECIFICATIONS

PROJECT NO : 1890
PROJECT TITLE : SSGCL HEAD OFFICE BUILDING, KARACHI
DATED : 20TH APRIL, 2026

All as built drawings shall show relative labels of each component

b) Wiring

- i. All wiring shall be installed in GI Pipe or aluminum tube. Conduit fill shall not exceed 40 percent of interior cross sectional area where three or more cables are contained within a single conduit.
- ii. Cable must be separated from any open conductors of Power, or Class 1 circuits, and shall not be placed in any conduit, junction box or raceway containing these conductors,
- iii. Wiring for 24-volt control, alarm notification, emergency communication and similar power-limited auxiliary functions shall be run in separate conduit from other initiating and signaling line circuits. All circuits shall be provided with transient suppression devices and the system shall be designed to permit simultaneous operation of all circuits without interference or loss of signals.
- iv. Conduit shall not enter the control panel or any other remotely mounted control panel equipment or back boxes, except where conduit entry is specified by the manufacturer.
- v. All hangers, supports, mounts shall be deemed to be included in contract
- vi. GI Pipe

Where required, external wiring shall be carried out in extra light-quality hot-dip galvanised steel pipe, to BS 137, minimum 15mm dia, installed as above. All accessories (bends, sockets, reducers, couplers, checknuts, etc.) shall also be galvanised.

Accessories

Conduit accessories, to BS 31, shall be cast-iron or of 16 b.g sheet steel, with protective treatment as above. Conduit terminations shall be provided with soft, rounded, brass bushes and lock nuts. Saddles shall be of the heavy-duty hospital-type, and shall be installed at spaces recommended by the IEE Regulations. Additional supports in the form of 40mm x 3mm flats or 40mm x 40mm x 3mm angle iron shall be provided wherever necessary. No welding to the structure shall be permitted.

Flexible/Pliable

Flexible steel conduit BS 731/6099, shall be used with appropriate glands for terminating all connections from concealed/surface junction boxes to devices. The flexible conduit shall be encased in water-proof plastic PVC, retained with jubilee-clips. Ends of the conduit shall be welded to brass couplers/adapters.

5. **Warranty & Maintenance**

The Contractor shall provide warranty and free service & maintenance, covering materials and labour.

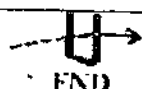

Fahim, Nanji & deSouza (Pvt.) Ltd
Consulting Engineers

Raceways/Boxes
Section 26 05 33



PROJECT NO : 1890

SPECIFICATIONS

PROJECT TITLE : SSGCL HEAD OFFICE BUILDING, KARACHI

DATED : 20TH APRIL, 2026**LIST OF APPROVED MANUFACTURERS (HVAC WORKS)**

Equipment & Material shall be supplied only from the approved sources noted below. However in all cases the Contractor shall submit complete technical details of the equipment, material and obtain Consultants approval prior to delivery on site. Where option of "Approved Equivalent" is indicated, it shall be at the discretion of the Consultant to accept the alternate proposal submitted by the Contractor.

CSI No.	Equipment/Material	Approved Manufacturers	Country of Origin
23 05 13	Motors	Siemens	Imported
		ABB	Imported
		Imported	USA/Europe/Japan
23 05 19	Thermometers / Pressure Gauges	Trelice, WGTC, Weksler, Weiss, Brennan	USA/UK
23 05 23	Gate Valves, Globe Valves, Strainers, Check Valves Ball Valves	Kitz	Japan
		Duyar	Turkey
		Scon	Pakistan
	Butterfly Valves	Hattersley/Crane	UK/China
		Tomoe	Japan/Indonesia
		Duyar	Turkey
23 05 29	Supports & Anchors	Scon	Pakistan
		Index	Spain
		Fischer	Germany
	Concrete Fasteners	Fixotec	China
		Rawal Plug	UK
23 05 50	Paint	Berger	Pakistan
		ICI	Pakistan
23 07 13	Duct Work Insulation (Fiberglass)	Afico	Saudi Arabia
		Kimco	Kuwait
		Knauf	Germany
	Insulation Adhesive	Zahabiya	Pakistan
		Ductmate Inc.	USA
23 07 19	Piping Insulation	Aeroflex (EPDM)	Thailand
	Closed Cell Foam Insulation	Forteflex (EPDM)	China
23 21 30	Centrifugal Pumps	Xylem	Poland
		Ebara	Indonesia
		KSB	Pakistan/Imported
		Wilo	Europe
23 73 10	Cooling Coils	Breeze Air Conditioning	Pakistan
		Kold Kraft	Pakistan
		Approved Equivalent	Pakistan
23 09 20	Automatic Control System	Siemens (Approved Distributor: MEP Solutions/Avanceon)	Imported
		Alerton (Approved Distributor: Accrescent Engineering)	Imported
		Schnelder (Approved Distributor: CNSE)	Imported
		Airtek (Approved Distributor: Comfort Control)	Imported
		Johnson Controls (Approved Distributor: Shan Controls)	Imported
		Schnelder (Approved Distributor: IMS)	Imported
23 21 13	Hydronic Piping & Specialties		
		Black Steel, Schedule 40 Pipe (Seamless)	Protek
	uPVC	Baoloi (Pacific)	China
		Dadex	Pakistan
		Cosmoplast	UAE
		Hakkan GF	UAE
		Plasco	Pakistan
	Make-up Water (Poly Propylene Pipes-PPR)	Dadex	Pakistan
		III	Pakistan
		Plasco	Pakistan
	Flexible Connectors	Tozen	Japan
		Duyar	Turkey
		Proco	Indonesia/Malaysia
Approved Equivalent		Imported	



PROJECT NO : 1890

PROJECT TITLE : SSGCL HEAD OFFICE BUILDING, KARACHI

DATED : 20TH APRIL, 2026

SPECIFICATIONS

CSI No.	Equipment/Material	Approved Manufacturers	Country of Origin
23 31 13	Sheet Metal (For Machine Made Ducting)	International Steel Limite (ISL)	Pakistan
		Aisha Steel	Pakistan
23 86 20	Flow Balancing Valves	Scon	Pakistan
		Duyar	Turkey
		Hattersley/Crane	UK/China
23 25 13	Chemicals	Drew Ameroid	USA
		Houseman	UK
		Approved Equivalent	-
		Bypass Feeder	IME
23 25 17	Water Treatment Equipment	Orient Water Services	Pakistan
		Approved Equivalent	-
		LMI	USA
23 31 13	Sheet Metal (For Machine Made Ducting)	GEC	USA
		Approved Equivalent	-
23 31 13	Sheet Metal (For Machine Made Ducting)	International Steel Limite (ISL)	Pakistan
		Aisha Steel	Pakistan
23 86 35	Air Vents	Hattersley	UK/China
		Scon	Pakistan
		Duyar	Turkey
		Approved Equivalent	Imported
23 87 10	Power Cables	Pakistan Cables	Pakistan
		Pioneer Cables	Pakistan
		Indus Cables	Pakistan
		Newage Cables	Pakistan
		Control Cables (LSZH, Fire Resistant Cables)	
	Belden	<p>Procured from authorized distributors/suppliers: some of them are: Draka Cables, Karachi Office No. 610, 6th Floor, Progressive Centre, 30-A, Block No. 6, P.E.C.H.S, Karachi. Tel: +92 21 4383238-9, Fax: +92 21 4537138 Integrated Engineering Services (Pvt)Ltd. 38A (Commercial) 1st Floor, Sector-XX Kahayban-e-Iqbal PhaseIII, DHA, Lahore-54792, Pakistan Tel: +92-42-35693810/11 or 35693739. Fax: +92-42-35722954 Excel Technological Services 235-S, Street No.11 DHA Lahore, Pakistan, 54796 Phone 92-42-5734740 Fax 92-42-5734742 M/s Maxwell Automation, House No A-5, Sector 9, Ahmed Raza Road North Karachi Ph: 042-3586-1522. M/s OBA International, office No. 8, First Floor, Masco Plaza, 64 West, H-Block, Jinnah Avenue, Blue Area, Islamabad-Pakistan Tel: +92-51-2270707, 4305730 M/s. C-XOR Engineering, 199 A4, P.C.E.C.H.S. Near Wapda Town Lahore, Pakistan. Tel: +9242-3612 6722, 3518 0653, Fax: +9242-3518 1114 M/s ELAND CABLES Imran Shah :International Projects Manager Direct: +44 (0)20 7241 8738 Mobile: +44 (0)7980 712 535 Office: +44 (0)20 7241 8740 Fax: +44 (0)20 7241 8700 Web: http://www.elandcables.com</p>	
	FCT		
	Cavicel		
	Prysmian/Draka		
	Nexan		
	Eland Cables		
	ZM Kablo		
	Datwyler		
	Steel Conduits		Steelex
		lil	Pakistan
	Circuit Breakers/Contractors	ABB	Imported
		Schneider	Imported
		General Electric	Imported
		Siemens	Imported
	Cable Tray	Electroline	Pakistan
		Ezzi	Pakistan

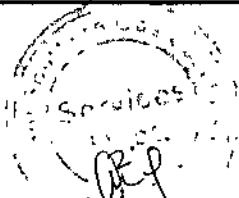

PROJECT NO : 1890

SPECIFICATIONS

PROJECT TITLE : SSGCL HEAD OFFICE BUILDING, KARACHI

DATED : 20TH APRIL, 2026

CSI No.	Equipment/Material	Approved Manufacturers	Country of Origin
23 87 15	Control Panel (MCC) Manufacturers	Hussain & Co.	Pakistan
		Power engineers	Pakistan
		Taj engineering	Pakistan
		MOBASCO	Pakistan
23 87 20	Variable Frequency Drives	HRA Switchgear	Pakistan
		Siemens	Germany
		Schneider	Europe
		ABB	Finland
		Danfoss (VLT Series FC-102)	Denmark



Fahim, Nanji & deSouza (Pvt.) Ltd.
Consulting Engineers

List of Approved Manufacturers (HVAC Wor
Section 23:90 10







FOR OBSERVATION ROOM (BY SSGCL)







Recommended Brand for the Sandwich Panels

	 <p>TEK ENGINEERING SERVICES SANDWICH PANELS PRE-ENGINEERED BUILDINGS</p>
 <p>PAKISTAN INSULATIONS</p>	
	 <p>UNCORN CHEMICALS (Pvt) Ltd. Quality you can trust.</p>

Recommended Brand for the Double Glazed Glass Panels

 <p>WINGLASS Windows & Doors System</p>	 <p>Ghani GHANI VALUE GLASS LIMITED</p>
	 <p>TARIQ GLASS INDUSTRIES LTD.</p>

Recommended Brand for the UPVC Windows frames

 <p>alfawin uPVC Door & Window System</p>	 <p>SKYPEN uPVC Windows & Door Systems</p>
	
 <p>EUROPROFILO Premium European Quality uPVC Window and Door Profiles</p>	 <p>FRAMEZ Quality Window and Door Systems</p>
	



Handwritten signature and date

FOR OBSERVATION ROOM (BY SSGCL)

Recommended Brand for the Lights	
Orient	Philips
Osaka	Alfanar



3

**SSGCL HEAD OFFICE BUILDING,
KARACHI**

Equipment Data Sheets

HVAC Works



Fahim, Nanji & deSouza (Pvt.) Ltd.
Consulting Engineers



	EQUIPMENT DATA SHEET	SHEET 1 OF 1	DATA SHEET NO. 1890-23 07 13 - 1 / 1
	DUCT WORK INSULATION	PROJECT TITLE : SSGCL HEAD OFFICE BUILDING	
		PROJECT NO. : FND/1890	
		LOCATION : KARACHI	
DATA			REV

1 IDENTIFICATION SYMBOL
 2 SPECIFICATIONS REFERENCE 23 07 13
 3 FND CALC. REF. NO.

INSULATION							
4 ID NO.	APPLICATION	MATERIAL	THICKNESS (Inch)	THERMAL CONDUCTIVITY (BTU/hr ft ² F)	DENSITY (lb./ft ³)	VAPOUR BARRIER	COATING / JACKET / CLADDING
5	DUCT INSULATION						
6	ID1 Supply Air Duct - Air Conditioned Space / Air Conditioned Ceiling Cavity	Fiberglass Blanket	1.0	0.24 @75°F	1.5	FRK (Foil Reinforced Kraft)	25mm x 25mm G.I (24 Gauge) Angles at all 4 Edges, Plastic Straps @ 3ft C/C
7	ID2 Supply / Return Air Duct - Non Air Conditioned Space	Fiberglass Blanket	2.0	0.24 @75°F	3.0	FRK (Foil Reinforced Kraft)	25mm x 25mm G.I (24 Gauge) Angles at all 4 Edges, Plastic Straps @ 3ft C/C
8	ID3 Supply / Return Air Duct - Mechanical Room or Exposed to Atmosphere or Susceptible to Damage	Fiberglass Board	2	0.24 @75°F	3	FRK (Foil Reinforced Kraft)	26 Gauge G.I Sheet Cladding
9							
10							
11							
12							
13							
14							
15							
16							
17							
18							
19							
20							
21							
22							
23							
24							
25							
26							
27							
28							
29							
30							
31							
32							
33							
34							
35							
36							
37							
38							
39							
40							
41							
42							
43							
44							
45							
46							
47							

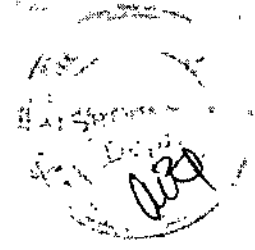

REVISION	0	1
STATUS	ISSUED FOR TENDER	ISSUED FOR TENDER
DATE	19/05/2025	20/04/2026
CHECKED / SIGN.	DANIAL ABDUL AZIZ	DANIAL ABDUL AZIZ
APPROVED	FAHAD ABDULLAH	FAHAD ABDULLAH

THE INFORMATION ON THIS DATA SHEET IS CONFIDENTIAL TO FAHIM, NANJI & DESOUZA (PVT) LTD AND SHALL NOT BE DISCLOSED TO A THIRD PARTY WITHOUT PRIOR WRITTEN PERMISSION



	EQUIPMENT DATA SHEET PIPING INSULATION	SHEET 1 OF 1	DATA SHEET NO.
		REV 1	1890-23 07 19 - 1/1
		PROJECT TITLE: SSGCL HEAD OFFICE BUILDING	
		PROJECT NO.: FND/1890	
		LOCATION: KARACHI	
DATA			REV

- 1 IDENTIFICATION SYMBOL
- 2 SPECIFICATIONS REFERENCE 23 07 19
- 3 FND CALC. REF. NO.:

4 ID NO.	APPLICATION	MATERIAL	THICKNESS (mm)	INSULATION			COATING / JACKET / CLADDING
				THERMAL CONDUCTIVITY (BTU/hr. ft ² °F)	DENSITY (lb./ft. ³)	VAPOUR BARRIER	
5	CHILLED & HOT WATER PIPE INSULATION						
6	WP1 Piping in Mechanical Room & Plant Room	Closed Cell Foam Class 0 (EPDM) (Fire Retardant)	25mm thk. (Upto 10") 32mm thk. (>ø10") 40mm thk. (>ø12")	0.26 @75°F	4.1 to 4.4	-	28 Gauge G.I Sheet Cladding
7							
8							
9							
10							
11							
12							
13							
14							
15							
16							
17							
18							
19							
20							
21							
22							
23							
24							
25							
26							
27							
28							
29							
30							
31							
32							
33							
34							
35							
36							
37							
38							
39							
40							
41							
42							
43							
44							
45							
46							
47							
48							
49							
50							
51							
52							
53							
54							
55							
56							
57							

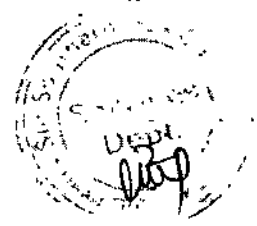

REVISION	0	1
STATUS	ISSUED FOR TENDER	ISSUED FOR TENDER
DATE	17/10/2025	20/04/2026
CHECKED / SIGN.	DANIAL ABDUL AZIZ	DANIAL ABDUL AZIZ
APPROVED	FAHAD ABDULLAH	FAHAD ABDULLAH

THE INFORMATION ON THIS DATA SHEET IS CONFIDENTIAL TO FAHIM, NANJI & DESOUZA (PVT.) LTD. AND SHALL NOT BE DISCLOSED TO A THIRD PARTY WITHOUT PRIOR WRITTEN PERMISSION



DWG. NO.
01

HVAC CONTROLS LIST OF DRAWING

DWG. NO.	DESCRIPTION
01	HVAC CONTROLS LIST OF DRAWING
02	HVAC CONTROLS LEGENDS & SYMBOLS
03	CONTROL SCHEMATIC FOR CENTRIFUGAL CHILLERS

[Handwritten signature]



DWG. NO.
02

HVAC CONTROLS LEGENDS & SYMBOLS

SYMBOL	LEGEND	SYMBOL	LEGEND
T	TEMPERATURE SENSOR	FS	FLOW SWITCH
H	RELATIVE HUMIDITY SENSOR		



Signature
Date

CONTROL SCHEMATIC FOR CENTRIFUGAL CHILLERS

NOTES:

1. OUT SIDE AIR MONITORED AT A SINGLE LOCATION FOR THE ENTIRE BUILDING & TRANSMITTED TO ALL CONTROLLERS VIA BMS.

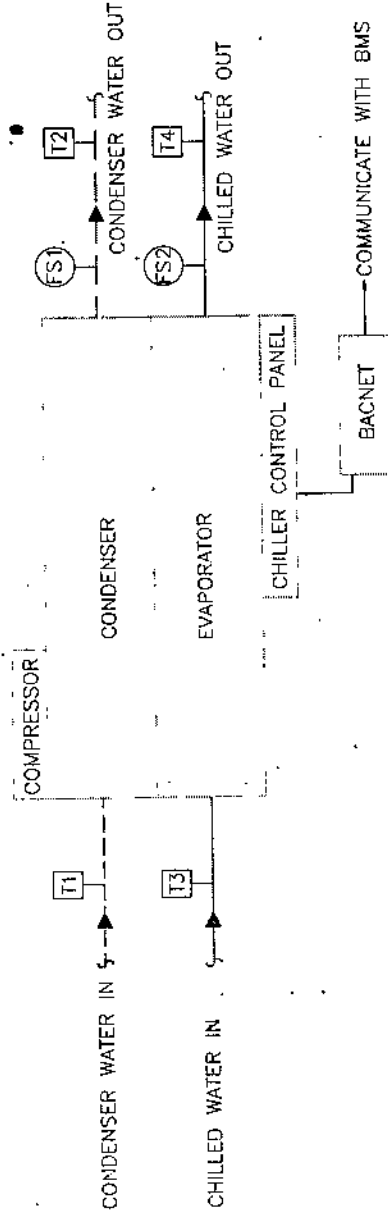

QUANTITY = 02 NOS.

ITEM NO.	DESCRIPTION OF FIELD DEVICES/FUNCTION	LOCATION	AI	DI	AO/DO	CONTROL LOGIC
START/STOP	CHILLER CONTROL PANEL	PLANT ROOM			02	CHILLER SHALL BE OPERATED BY USER DEFINED SCHEDULE ON BMS. ON RESTORATION OF POWER OUTAGE, CHILLER SHALL START AUTOMATICALLY. BMS SHALL COMMUNICATE WITH CHILLER MICRO PROCESSOR ON BACNET.
FS1	FLOW SWITCH	COND.WATER OUT			02	INDICATES FLOW ESTABLISHED. ALARMS, IF PUMPS ARE OPERATING AND FLOW IS NOT ESTABLISHED
FS2	FLOW SWITCH	CHW OUT			02	INDICATES FLOW ESTABLISHED. ALARMS, IF PUMPS ARE OPERATING AND FLOW IS NOT ESTABLISHED
T1	TEMPERATURE SENSOR	COND.WATER IN			02	FOR MONITORING PURPOSE
T2	TEMPERATURE SENSOR	COND.WATER OUT			02	FOR MONITORING PURPOSE
T3	TEMPERATURE SENSOR	CHW IN			02	FOR MONITORING PURPOSE
T4	TEMPERATURE SENSOR	CHW OUT			02	FOR MONITORING PURPOSE

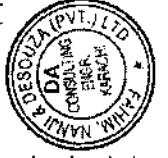

	EQUIPMENT DATA SHEET	SHEET 1 OF 1	DATA SHEET NO.
		REV 1	1890-22 11 16 / 23 21 13 - 1 / 1
	HYDRONIC PIPING & SPECIALITIES	PROJECT TITLE : SSGCL HEAD OFFICE BUILDING	
		PROJECT NO. : FND/1890	LOCATION : KARACHI

		DATA		REV	
1	SPECIFICATIONS REFERENCE	22 11 16 / 23 21 13			
2	FND CALC. REF. NO.:				
3	FND ID NO.:	APPLICATION	PIPING MATERIAL	STANDARD	REMARKS
4	WP1	Chilled, Hot & Condenser Water Piping	Seamless Black Steel, Schedule 40	ASTM A53 GRADE-B or A120 GRADE-B	Section 23 21 13
5					
6					
7					
8					
9					
10					
11					
12					
13					
14					
15					
16					
17					
18					
19					
20					
21					
22					
23					
24					
25					
26					
27					
28					
29					
30					
31					
32					
33					
34					
35					
36					
37					
38					
39					
40					
41					
42					
43					
44					
45					
46					
47					
48					
49					
50					
51					
52					
53					

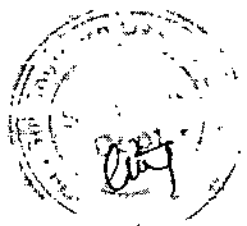

REVISION	0	1
STATUS	ISSUED FOR TENDER	ISSUED FOR TENDER
DATE	17/10/2025	20/04/2026
CHECKED / SIGN.	DANIAL ABDUL AZIZ	DANIAL ABDUL AZIZ
APPROVED	FAHAD ABDULLAH	FAHAD ABDULLAH

THE INFORMATION ON THIS DATA SHEET IS CONFIDENTIAL TO FAHIM, NANJI & DESOUZA (PVT.) LTD. AND SHALL NOT BE DISCLOSED TO A THIRD PARTY WITHOUT PRIOR WRITTEN PERMISSION



	EQUIPMENT DATA SHEET	SHEET	1	OF	2	DATA SHEET NO.	
		REV	2			1890-23 64 17 - 1 / 2	
	CENTRIFUGAL CHILLERS, WATER COOLED	PROJECT TITLE :	SSGCL HEAD OFFICE BUILDING				
		PROJECT NO. :	FND/1890				
	LOCATION :	KARACHI					

NO.	DESCRIPTION	DATA				REV
		UNIT	UNIT	UNIT	UNIT	
1	IDENTIFICATION SYMBOL	(IPS)	(IPS)	(SI)	(SI)	
2	SPECIFICATIONS REFERENCE	-	CH / 01 & 02	-	CH / 01 & 02	
3	FND CALC. REF. NO.	-	23 64 17	-	23 64 17	
4	QUANTITY	Nos.	2	Nos.	2	
5	ALTITUDE, AMSL	FT	13	m	4	
6	COOLING CAPACITY	Tons	375	kW	1318	
7	CHILLER COP AT FND SPECIFIED CONDITIONS	-	≥ 5.4	-	≥ 5.4	
8	CHILLER COP AT AHRU CONDITIONS	-	≥ 6.1	-	≥ 6.1	
9	CHILLED WATER FLOW RATE	USGPM	600	l/min	2271	
10	CHILLED WATER ENTERING TEMPERATURE	°F	57	°C	13.9	
11	CHILLED WATER LEAVING TEMPERATURE	°F	42	°C	5.6	
12	EVAPORATOR PRESSURE DROP	FT of Wg	6.7	m of Wg	2.0	
13	FOULING FACTOR EVAPORATOR	Sqft °Fhr/Btu	0.0005	m²K/W	0.089	
14	CONDENSER WATER FLOW RATE	USGPM	1125	l/min	4258	
15	CONDENSER WATER ENTERING TEMPERATURE	°F	90	°C	32.2	
16	CONDENSER WATER LEAVING TEMPERATURE	°F	100	°C	37.8	
17	CONDENSER WATER PRESSURE DROP	FT of Wg	3.5	m of Wg	4.1	
18	FOULING FACTOR CONDENSER	Sqft °Fhr/Btu	0.001	m²K/W	0.178	
19	REFRIGERANT	-	R-134a, R-410c, R-514a	-	R-134a, R-410c, R-514a	
20	ELECTRIC POWER	kW	283	kW	265	
21	POWER SUPPLY	V/Ph/Hz	400/3/50	V/Ph/Hz	400/3/50	
22	EVAPORATOR PRESSURE RATING	Psi	150	Kpa	1034.2	
23	CONDENSOR PRESSURE RATING	Psi	150	Kpa	1034.2	
24	HOURS OF OPERATION / YEAR	-	2250	HRS	2250	
25	TYPE	CENTRIFUGAL WATER COOLED, VARIABLE SPEED				
26	APPLICATION	AIR-CONDITIONING				
27	ACCESSORIES	- MICROPROCESSOR WITH BMS INTERFACE (BACNET / IP)				
28		- MARINE WATER BOXES				
29		- CHILLED & CONDENSER WATER FLOW SWITCHES / SENSORS				
30		- SOUND INSULATION				
31		- NEOPRENE ISOLATION PADS				
32		- SPARES - REFER SHEET 1890-23 64 17 - 2 / 2				
33						
34						
35	NOTES:					
36	1) IN CASE OF ANY DISCREPANCY IN THE VALUES NOTED IN IPS AND SI SYSTEM OF UNITS, VALUE NOTED IN IPS UNIT SHALL GOVERN.					
37	2) IN CASE OF ANY DISCREPANCY DATASHEET WILL PREVAIL OVER SPECIFICATIONS.					
38						
39						
40						
41						
42						
43						
44						
45						
46						
47						
48						
49						
50						
51						
52						
53						
54						
55						
56						
57						
58						



REVISION	0	1	2
STATUS	ISSUED FOR DRAFT TENDER	ISSUED FOR TENDER	ISSUED FOR TENDER
DATE	07/04/2025	16/04/2025	20/04/2026
CHECKED / SIGN.	DANIAL ABDUL AZIZ	DANIAL ABDUL AZIZ	DANIAL ABDUL AZIZ
APPROVED	FAHAD ABDULLAH	FAHAD ABDULLAH	FAHAD ABDULLAH

THE INFORMATION ON THIS DATA SHEET IS CONFIDENTIAL TO FAHIM, NANJI & DESOUBA (PVT.) LTD AND SHALL NOT BE DISCLOSED TO A THIRD PARTY WITHOUT PRIOR WRITTEN PERMISSION





EQUIPMENT DATA SHEET

SPARES FOR CENTRIFUGAL CHILLERS, WATER COOLED

SHEET 2 OF 2
REV 2

DATA SHEET NO.
1890-23 64 17 - 2 / 2

PROJECT TITLE : SSGCL HEAD OFFICE BUILDING

PROJECT NO. : FND/1890

LOCATION : KARACHI

		DATA		REV
	DESCRIPTION	QTY	UNIT	
1	VARIABLE SPEED DRIVE COMPONENTS	1	LOT	ELECTRONIC CARD OR AS RECOMMENDED BY MANUFACTURER
2	MICROPROCESSOR COMPONENTS	1	LOT	AS RECOMMENDED BY MANUFACTURER
3	LCD SCREEN	1	NO.	
4	COMPRESSOR OIL	1	LOT	FOR ONE CHILLER
5	REFRIGERANT LEVEL TRANSMITTER	1	NO.	
6	FLOW SENSOR	2	NOS.	1 NO. FOR EVAPORATOR + 1 NO. FOR CONDENSER
7	FUSES, RELAYS	1	LOT	OF EACH TYPE USED IN ONE CHILLER
8	CONTROL TRANSFORMER	1	NO.	
9	OIL FILTER	3	NOS.	
10	FILTER DRYER	3	NOS.	
11	RELIEF VALVE	2	NOS.	1 NO. FOR EVAPORATOR + 1 NO. FOR CONDENSER
12	REFRIGERANT			OF EACH CHILLER
13	SENSORS-TEMPERATURE / PRESSURE	3	NOS.	FOR EACH TYPE USED
14	SHAFT SEALS	1		
15	LIQUID SIGHT GLASS	1		
16	OIL PUMP	1		
17	OTHER SPARES AS RECOMMENDED BY THE MANUFACTURER FOR THREE YEARS NORMAL OPERATION OR AS INDICATED IN BOQ (TENDERER TO SPECIFY) FOR EACH CHILLER		LOT	AS RECOMMENDED BY MANUFACTURER
18	SPECIFIC MAINTENANCE TOOLS AS RECOMMENDED BY THE MANUFACTURER FOR EACH CHILLER	1	LOT	AS RECOMMENDED BY MANUFACTURER
19	CRITICAL SPARES/SINGLE POINT OF FAILURE COMPONENTS FOR MAINTAINING INVENTORY. (OPTIONAL) WITH PRICE LIST	1	LOT	AS RECOMMENDED BY MANUFACTURER
20	FIRST MAJOR OVERHAUL SPARES FOR EACH CHILLER. (OPTIONAL) WITH PRICE LIST	1	LOT	AS RECOMMENDED BY MANUFACTURER
21				
22				
23				
24				
25				
26				
27				
28				
29				
30				
31				
32				
33				
34				
35				
36				
37				
38				
39				
40				
41				
42				
43				
44				



REVISION	0	1	2
STATUS	ISSUED FOR DRAFT TENDER	ISSUED FOR TENDER	ISSUED FOR TENDER
DATE	07/04/2025	16/04/2025	20/04/2026
CHECKED / SIGN.	DANIAL ABDUL AZIZ	DANIAL ABDUL AZIZ	DANIAL ABDUL AZIZ
APPROVED	FAHAD ABDULLAH	FAHAD ABDULLAH	FAHAD ABDULLAH

THE INFORMATION ON THIS DATA SHEET IS CONFIDENTIAL TO FAHIM, NANJI & DESOUZA (PVT.) LTD. AND SHALL NOT BE DISCLOSED TO A THIRD PARTY WITHOUT PRIOR WRITTEN PERMISSION



	EQUIPMENT DATA SHEET AIR HANDLING UNITS	SHEET 1 OF 1	DATA SHEET NO. 1890-23 73 10 - 1 / 1
		REV 1	
		PROJECT TITLE: SSGCL HEAD OFFICE BUILDING	
		PROJECT NO.: FND/1890	
LOCATION: KARACHI			

NO.	DESCRIPTION	DATA				REV
		UNITS	(IPS)	(SI)	(SI)	
1	IDENTIFICATION SYMBOL	-	-	AMU / 02	-	-
2	SPECIFICATIONS REFERENCE	-	-	23 73 10	-	-
3	QUANTITY	No.	No.	1	-	-
4	FND CALC. REF. NO.:	-	-	-	-	-
5	ALTITUDE AMSL	FT	m	13	4	-
6	APPLICATION	-	-	FOR GROUND FLOOR OFFICE & AUDITORIUM AREA		-
7	COOLING COIL DATA:	-	-	-	-	-
8	TOTAL COOLING COIL LOAD	MBH	KW	107.3	207.3	-
9	SENSIBLE COIL LOAD	MBH	KW	514.5	150.8	-
10	SUPPLY AIR VOLUME	CFM	m ³ /hr	18,518	31,481	-
11	MAKEUP AIR VOLUME	CFM	m ³ /hr	2,697	4,585	-
12	BYPASS AIR VOLUME	CFM	m ³ /hr	-	-	-
13	ENTERING AIR, DRY BULB / WET BULB	°F	°C	80.5/68.5	27/19.2	-
14	LEAVING AIR, DRY BULB / WET BULB	°F	°C	54.0/53.0	12.2/11.2	-
15	WATER FLOW RATE	USGPM	L / min	94.2	357	-
16	ENTERING WATER TEMP. / LEAVING WATER TEMP.	°F	°C	45/60	7.2/15.6	-
17	COIL TYPE	-	-	CHILLED WATER		-
18	MINIMUM ROWS	Nos.	Nos.	4	4	-
19	MAXIMUM FINS/INCH	Nos/Inch	-	12	-	-
20	COATED COILS	-	-	NO		-
21	SATURATED SUCTION TEMPERATURE	°F	°C	-	-	-
22	FAN DATA (SUPPLY FAN)	-	-	-	-	-
23	TYPE OF FAN (NOTE - 04)	-	-	PLUG FAN		-
24	TYPE OF FAN BLADE	-	-	BACKWARD CURVE		-
25	SUPPLY AIR VOLUME	CFM	m ³ /hr	18,518	31,481	-
26	EXTERNAL STATIC PRESSURE (NOTE-1)	Inch of WG	Pascal	1.50	375	-
27	MOTOR POWER	KW	KW	15.0	-	-
28	POWER SUPPLY	V/PH/Hz	V/PH/Hz	400/3/50	-	-
29	FAN MOTOR VOLTAGE VARIATION	-	-	±10%		-
30	AHU MOTOR WINDING	-	-	YES		-
31	MECHANICAL PERFORMANCE OF CASING-EN 1886 (2007):	-	-	-	-	-
32	MECHANICAL LENGTH OF CASING (EN1886)	-	-	D1		-
33	CASING AIR LEAKAGE (at 400 Pa Negative Pressure) (EN1886)	-	-	L2		-
34	CASING AIR LEAKAGE (at 700 Pa Positive Pressure) (EN1886)	-	-	L2		-
35	FILTER BYPASS LEAKAGE (Maximum filter bypass leakage as % of nominal flow rate) (EN1886)	-	-	S1 (F8)		-
36	THERMAL TRANSMITTANCE (U) OF CASING (EN1886)	-	-	T2		-
37	THERMAL BRIDGING OF CASING (Thermal bridging factor k _s) (EN1886)	-	-	TB2		-
38	CONSTRUCTION:	-	-	-	-	-
39	TYPE	-	-	DOUBLE SKIN HORIZONTAL, DRAW THROUGH		-
40	HYGIENIC MODEL (REFER SPECIFICATION NO. 23 73 10)	-	-	NOT REQUIRED		-
41	MIXING BOX	-	-	YES		-
42	PANEL FILTER	-	-	NO		-
43	BAG FILTER	-	-	NO		-
44	HEPA FILTER SECTION WITH FILTERS	-	-	NO		-
45	RETURN AIR FAN	-	-	NO		-
46	EMPTY ACCESS SECTION	-	-	AS PER MANUFACTURER RECOMMENDATION		-
47	BYPASS SECTION	-	-	NO		-
48	ULTRAVIOLET & GERMICIDAL IRRADIATION (UVGI) LAMP (AIRBORNE TYPE)	-	-	NO		-
49	WEATHERPROOF CONSTRUCTION & CANOPY	-	-	NO		-
50	SOUND ATTENUATOR	-	-	NO		-
51	MAXM. ALLOWABLE UNIT DIM. (L X W X H)	m x mm x m	-	4400 X 2350 X 2300		-
52	VIEW PORT	-	-	YES (NOTE-03)		-
53	LIGHTS	-	-	YES (NOTE-06)		-
54	MAGNETIC GAUGES (0 - 5 Inch of WG)	-	-	YES (NOTE-11)		-
55	HEAT EXCHANGER	-	-	-		-
56						
57	SPARES	QUANTITY	UNITS	REMARKS		
58	(a) FAN BEARINGS	1	Set	For each Fan		
59	(b) FILTERS (Each Type)	1	Set	For each AHU		
60	(c) MOTOR	1	No.	For each KW Rating		
61						
62	NOTES:					
63	1) EXTERNAL STATIC PRESSURE DATA INCLUDES ONLY PRESSURE DROP EXTERNAL TO AHU. PRESSURE DROP ACROSS AHU & COIL ARE NOT INCLUDED.					
64	2) MOISTURE ELIMINATOR TO BE PROVIDED FOR COIL FACE VELOCITIES EXCEEDING 550 FPM.					
65	3) AHU PANEL THICKNESS SHALL BE 50MM.					
66	4) FAN IS TO BE SELECTED AT HIGHEST EFFICIENCY SEGMENT OF FAN CURVE BUT EFFICIENCY SHOULD NOT BE LESS THAN 65%.					
67	5) VIEW PORT TO BE PROVIDED IN FAN SECTIONS & FILTER SECTIONS					

OWNER FURNISHED

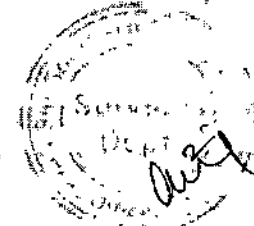

 FND	EQUIPMENT DATA SHEET	SHEET 1 OF 1	DATA SHEET NO. 1890-23 73 10 - 1/1
	AIR HANDLING UNITS	PROJECT TITLE : SSGCL HEAD OFFICE BUILDING	
		PROJECT NO. : FND/1890	
		LOCATION : KARACHI	
	DATA		REV

DESCRIPTION	UNIT	(IPS)	(SA)	(IPS)	(SA)
68) LIGHT TO BE PROVIDED IN FAN SECTION & BAG FILTER ACCESS/EMPTY SECTION & SECTIONS HAVING PORT HOLES.					
7) PROVIDE AIR TAPS WITH CAPS FOR INSTALLATION OF MANOMETER / PRESSURE SENSORS: - FILTER SECTIONS - 4 PER SECTIONS - FAN SECTIONS - 2 PER SECTIONS					
8) IN CASE OF ANY DISCREPANCY IN THE VALUES NOTED IN IPS AND SI SYSTEM OF UNITS, VALUE NOTED IN IPS UNIT SHALL GOVERN.					
9) MOTOR SHALL BE HIGH EFFICIENCY MOTORS - CLASSIFIED AS IE-3.					
10) DRAIN CONNECTION SHOULD BE PROVIDED WITH THREADED CONNECTION					
11) MAGNETIC GAUGES SHALL BE PROVIDED FOR ALL FILTERS SECTIONS & FAN SECTION. RANGE OF MAGNETIC GAUGE SHALL BE 0-5 INCH OF WATER COLUMN.					
12) ALL AHU SECTIONS SHALL BE MOUNTED ON A GALVANISED STRUCTURAL BASE MINIMUM 180MM HIGH, EXTENDING TO THE FULL LENGTH OF THE AIR-HANDLING UNIT.					
13) FILTER PRESSURE DROP SHALL BE BASED ON MEDIUM PRESSURE DROP OF FILTERS					
14) FAN SELECTION SHALL BE CARRIED OUT AT 50 Hz OR BELOW					
15) UGV LAMP SHALL BE AT DOWNSTREAM OF COOLING COIL.					
16) AHU SHALL BE PROVIDED WITH ISOLATOR SWITCH FOR MOTOR. WIRING FROM ISOLATOR SWITCH TO MOTOR SHALL BE IN AHU SUPPLIER SCOPE.					
17) VFDs TO BE PROVIDED BY AHU MANUFACTURER AND SHALL BE UNIT MOUNTED.					
18) VFD SHALL BE PROVIDED WITH EMC & RFI FILTERS AS PER EN 5501					
19) VFD SHALL BE PROVIDED WITH DC CHOKE.					
20) VFD SHALL BE COMPATIBLE TO COMMUNICATE WITH BMS. THE COMMUNICATION PROTOCOL SHALL BE SACNET/MSTP					
21) VFD SHALL BE PROVIDED WITH IP-55 PROTECTION CLASS.					
22) FAN SELECTION SHALL BE CARRIED OUT AT 50 Hz OR BELOW.					
23) WIRING (100% SHIELDED CABLE) FROM VFD TO MOTOR SHALL BE IN AHU SUPPLY SCOPE					
24) VFD KW RATING SHOULD BE SELECTED ONE SIZE HIGHER THAN THE RATED MOTOR POWER TO ACCOUNT FOR DERATING OF THE VFDs DUE TO HIGH AMBIENT TEMPERATURE. EXPECTED AMBIENT TEMPERATURE IS 45 TO 48 °C.					
25) VFD TO BE PROVIDED WITH BUILT-IN PROTECTION AS MENTIONED IN THE SPECIFICATIONS, IF ADDITIONAL PROTECTION (AS PER MANUFACTURER RECOMMENDATION) IS REQUIRED, KINDLY INDICATE AND PROVIDE DETAILS.					

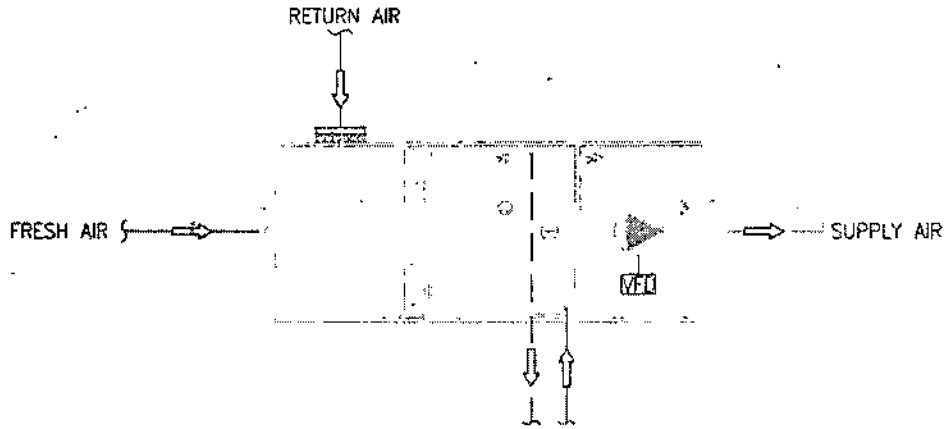

REVISION	0	1
STATUS	ISSUED FOR TENDER	ISSUED FOR TENDER
DATE	17/10/2025	20/04/2026
CHECKED / SIGN.	DANIAL ABDUL AZIZ	DANIAL ABDUL AZIZ
APPROVED BY	FAHAD ABDULLAH	FAHAD ABDULLAH

THE INFORMATION ON THIS DATA SHEET IS CONFIDENTIAL TO FAHIM, NANJI & DESOUZA (PVT.) LTD AND SHALL NOT BE DISCLOSED TO A THIRD PARTY WITHOUT PRIOR WRITTEN PERMISSION





SELECTION DATA		PROJECT	CONSULTANT
MOTOR CONTROL CENTER		SSGCL HEAD OFFICE BUILDING, KARACHI	FAHIM, NANJI & DESOUZA (PVT.) LTD.

INSTALLATION GUIDE LINES:	
1	Work shall be carried out in accordance with the 16th Edition of the IEE/UK "Regulations for Electrical Installations", and to the requirements of the Electrical Inspector.
2	Ratings and data given are nominal and indicative only. Contractor shall supply cabling and switch gear that is compatible with the supplied. HVAC/mechanical equipment ratings.
3	Power cabling shall be PVC/PVC 600/1000V grade copper conductor cable run in raceway, as follows: <ul style="list-style-type: none"> • Medium-duty (1.5mm) hot dipped galvanized after fabrication (HDGAF), perforated (40% free area) cable tray, with HDGAF fixing and suspension accessories. • 16 SWG enamelled steel conduit, with hospital-type saddles. • Extra-light quality GI pipe (under-ground or outdoors). • Flexible plastic-covered ("light-light") metal conduit (maximum length 600mm) at equipment termination.
4	Control cabling shall be PVC/PVC 600/1000V grade multicore copper conductor, run in separate raceway, as above.
5	Circuit protective conductors (CPC) shall be stranded HDBC (2 Nos.), connected to all motors, raceways, panels and electrical equipment at two points.
6	All conductor terminations, joints, and tap-offs shall be provided with crimped copper lugs and ferrules.
7	Voltage relay (adjustable) for under/over/reverse phase voltages

8	MCC shall be provided with <ul style="list-style-type: none"> • Incoming load-break switch (AC-23 duty) with ammeter/CTs/ASS, Voltmeter/VSS, and phase lamps. • MCCB feeders, as shown. • Motor-starter feeders, as shown, with MCCB back-up protection (type 2 to IEC 947) motor-protection (AC3-duty) magnetic contactors, 3-pole differential-type thermal overload relay with "hand/auto-reset", "on/off" push buttons, "hand/off/auto" selector SWI. • Service socket outlets, single-phase and three-phase, as required. 	9	Provide local weatherproof isolator/disconnect near each motor that is out of line-of-sight of MCC.
10	Provide all power and control connections and cabling to all package equipment, as required by the manufacturer.	11	Provide all control inter-connections and cabling in accordance with the control logic defined elsewhere/below. <ul style="list-style-type: none"> a) Interlock Electric Chiller with Primary and Condenser Pumps. b) Provide "HOA" switches to allow remote start up in "Auto" position. c) MCC supplier ensure that chillers should be start automatically after restoration of power supply.

NO.	REVISIONS	DATE	CHECKED	APPROVED	FORM NO.:	PAI
0	ISSUED FOR TENDER	17/10/2025	DANIAL ABDUL AZIZ	FAHAD ABDULLAH	DS-23 87 15	
1	ISSUED FOR TENDER	20/04/2026	DANIAL ABDUL AZIZ	FAHAD ABDULLAH		



SELECTION DATA		PROJECT		CONSULTANT	
MOTOR CONTROL CENTER		SSGCL HEAD OFFICE BUILDING, KARACHI		FAHIM, NANJI & DESOUZA (PVT.) LTD.	
MCC NO.:	MCC/01	VOLTAGE:	400	MOUNTING: <input type="checkbox"/> WALL <input checked="" type="checkbox"/> FLOOR	
LOCATION	Plant Room	PHASE:	3	ICU = 50KA	
IP CLASS:	42	BUS RTG:	1250A	ICs = 50% of ICU	

S.NO	DESCRIPTION	UNITS	IDENTIFICATION NO.				CH / 01 & 02	SP/01	Control CKT	
			Incoming from TF1	Incoming from TF2	Incoming from Waukesha Genset	Incoming from Guascor Genset				
1	Feeder	-								
2	Equipment Location	-							Lower Ground Floor (Plant Room)	
3	Connected Load	KW	530.0	530.0	530.0	530.0	265 x 2			
4	Full Load Current	Amps	957	957	957	957	478			
5	MCCB/MCB	Amps	1250	1250	1250	1250	800 x 2		10	
6	Phase	-	3	3	3	3	3		3	
7	Ammeter	Amps	✓	✓	✓	✓	x		1	
8	Volt meter	Volts	✓	✓	✓	✓	x			
9	Equipment Provided with Control Panel	-	-	-	-	-	✓			
10	Starters	DOL	-	-	-	-	x			
11	Hour-meter	Star/Delta	-	-	-	-	x			
12	Auto-Interlocks	VFD	-	-	-	-	✓			
13	Thermistor Relay in Motor	-	-	-	-	-	✓			
14	Remote Control	-	-	-	-	-	✓			
15	Remote Indicator	-	-	-	-	-	x			
16	Remote Isolator Near Equipment (Weather Proof)	-	-	-	-	-	x			
17	Cable	1 Core	3 x 4 x 1c x 300 mm ² Cu PVC/PVC	3 x 4 x 1c x 300 mm ² Cu PVC/PVC	3 x 4 x 1c x 300 mm ² Cu PVC/PVC	3 x 4 x 1c x 300 mm ² Cu PVC/PVC	2 x 3 x 1c x 185 mm ² Cu PVC/PVC (Qty 02)			
		3 Core	-	-	-	-	-			
		3 1/2 Core	-	-	-	-	-	-		
		4 Core	-	-	-	-	-	-		
18	Conduit	mm	Cable Tray	Cable Tray	Cable Tray	Cable Tray	Cable Tray			
19	CPC-2 Nos.	mm ²	1c x 70 mm ² Cu CPC [2 Nos.]	1c x 70 mm ² Cu CPC [2 Nos.]	1c x 70 mm ² Cu CPC [2 Nos.]	1c x 70 mm ² Cu CPC [2 Nos.]	Water Cooled Centrifugal Chillers	Spare	DDC Controller	
20	Remarks	-	Mechanical Interlocking is required between 4 incoming breakers, 1 will be ON & 3 will be Off							

NO.	REVISIONS	DATE	CHECKED	APPROVED	FORM NO.:	PAGE NO.:
0	ISSUED FOR TENDER	17/10/2025	DANIAL ABDUL AZIZ	FAHAD ABDULLAH	DS-23 87 15	
1	ISSUED FOR TENDER	20/04/2026	DANIAL ABDUL AZIZ	FAHAD ABDULLAH		



Handwritten signature and stamp at the bottom right corner.

SELECTION DATA		PROJECT		CONSULTANT	
MOTOR CONTROL CENTER		SSGCL HEAD OFFICE BUILDING, KARACHI		FAHIM, NANJI & DESOUZA (PVT.) LTD.	
MCC NO.:	MCC/B-01	VOLTAGE:	400	MOUNTING:	<input type="checkbox"/> WALL <input checked="" type="checkbox"/> FLOOR
LOCATION:	BUILDING ROOF	PHASE:	3	ICU = 20 KA	
IP CLASS:	42	BUS RTC:	40	ICU = 50% of ICU	

S.NO	DESCRIPTION	UNITS	Incoming	AHU / 02	SP/01	IDENTIFICATION NO.
1	Feeder	-				Control CKT
2	Equipment Location	-		BASEMENT PLANT ROOM		
3	Connected Load	KW	15.0	1 x 15		
4	Full Load Current	Amps	27	1 x 27.1		
5	MCCB/MCB	Amps	40	1 x 40	40	10
6	Phase	-	3	3	3	1
7	Ammeter	Amps	✓	x		
8	Volt meter	Volts	✓	x		
9	Equipment Provided with Control Panel	-		x		
10	Starters	DOL		x		
		Star/Delta		x		
		VFD		✓		
11	Hour-meter	-		✓		
12	Auto-Interlocks	-		✓		
13	Thermistor Relay in Motor	-		x		
14	Remote Control	-		x		
15	Remote Indicator	-		x		
16	Remote Isolator Near Equipment (Weather Proof)	-		✓		
17	Cable	mm ²	-	-		
		mm ²	-	-		
		mm ²	1 x 6	1 x 6		
18	Conduit	mm	Cable Tray	Cable Tray		
19	CPC-2 Nos.	SWG	14	14		
20	Remarks			FOR GROUND FLOOR OFFICE & AUDITORIUM	Spare	DOC Controller

NO.	REVISIONS	DATE	CHECKED	APPROVED	FORM NO.:	PAGE NO.:
0	ISSUED FOR TENDER	17/10/2025	DANIAL ABDUL AZIZ	FAHAD ABDULLAH	DS-23 87 15	3/2
1	ISSUED FOR TENDER	20/04/2026	DANIAL ABDUL AZIZ	FAHAD ABDULLAH		



[Handwritten signature and stamp]

NOT BEING A REGISTERED ELECTRICAL ENGINEER, THE DESIGNER HAS NOT BEEN LICENSED BY THE BOARD OF ELECTRICAL ENGINEERS AND ARCHITECTS TO SEAL OR SIGN ANY ELECTRICAL DRAWING OR SPECIFICATION. WITHOUT THE WRITTEN PERMISSION OF THE BOARD OF ELECTRICAL ENGINEERS AND ARCHITECTS, THIS DRAWING IS NOT TO BE REPRODUCED OR COPIED IN ANY MANNER.

NO.	REVISION	DATE	BY	CHKD.
01	ISSUE FOR PERMIT			
02	ISSUE FOR WORK			
03	ISSUE FOR RECORD			
04	REVISIONS			

PROJECT: SSGCL HEAD OFFICE BUILDING, KARACHI

DESIGNER: FAHRI KHALIL & HUSSAIN (PVT) LTD
 CONSULTING ENGINEERS
 10-A, THE TRADE CENTRE BUILDING, SECTOR 10, PHASE 1, DHA PART II, KARACHI-75200, PAKISTAN.
 TEL: 37324444, 37324445, 37324446, 37324447, 37324448, 37324449, 37324450, 37324451, 37324452, 37324453, 37324454, 37324455, 37324456, 37324457, 37324458, 37324459, 37324460, 37324461, 37324462, 37324463, 37324464, 37324465, 37324466, 37324467, 37324468, 37324469, 37324470, 37324471, 37324472, 37324473, 37324474, 37324475, 37324476, 37324477, 37324478, 37324479, 37324480, 37324481, 37324482, 37324483, 37324484, 37324485, 37324486, 37324487, 37324488, 37324489, 37324490, 37324491, 37324492, 37324493, 37324494, 37324495, 37324496, 37324497, 37324498, 37324499, 37324500.

POWER DISTRIBUTION SCHEMATIC

DATE: _____
 CHECKED: _____
 APPROVED: _____
 REV NO: 01 DRAWING NO: ENR-1900-11

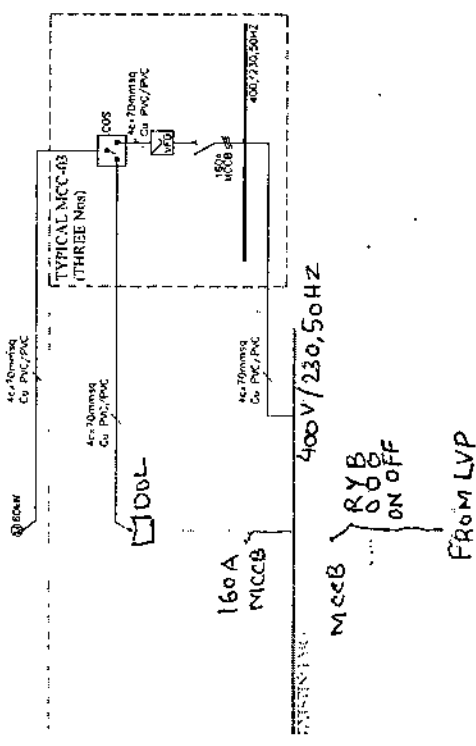
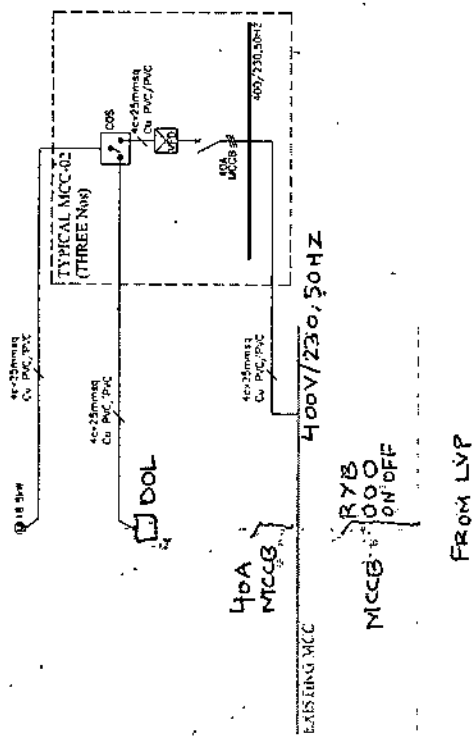

	EQUIPMENT DATA SHEET VARIABLE FREQUENCY DRIVES (VFD's)	SHEET 1 OF 1	DATA SHEET NO.
		REV. 1	1890-23 87 20 - 1/1
		PROJECT TITLE : SSGCL HEAD OFFICE BUILDING	
		PROJECT NO. : FND/1890	
LOCATION : KARACHI			

	DESCRIPTION	UNIT	DATA (IPS)	REV
1	IDENTIFICATION SYMBOL	-	VFD/P/ 01-03 VFD/P/ 08-08	
2	SPECIFICATIONS REFERENCE	-	23 87 20 23 87 20	
3	FND CALC. REF. NO.	-	-	
4	QUANTITY	Nos	3 3	
5	MOTOR POWER	kW	18.6 59.7	
6	RATED OUTPUT CURRENT	Amperes	- -	
7	POWER SUPPLY	V/Ph/Hz	400/3/50 400/3/50	
8	INPUT VOLTAGE VARIATION	%	10 10	
9	INPUT FREQUENCY	Hz	50 50	
10	OUTPUT FREQUENCY	Hz	5-60 5-60	
11	MOTOR EFFICIENCY	%	90 90	
12	PARALLEL OPERATION APPLICATION	N	N	
13	NO. OF MOTORS IN PARALLEL OPERATION	No.	N/A N/A	
14	ELECTRIC POWER OF EACH MOTOR	kW	- -	
15	MOTOR MAXIMUM SPEED	Rpm	1450 2965	
16	DISTANCE OF VFD FROM MOTOR	Ft	200 250	
17	MAXIMUM AMBIENT AIR TEMPERATURE	°F	104 104	
18	DEGREE OF PROTECTION FOR VFD	IP	55 55	
19	FILTERS	-	EMC & RFI as per EN 5501 EMC & RFI as per EN 5501	
20	HARMONIC FILTER	-	DC-CHOKE	
21	COMMUNICATION PROTOCOL	-	BACnet	
22	CONSTRUCTION	-	-	
23	TYPE	-	-	
24	APPLICATION	-	PRIMARY CHILLED WATER PUMPS CONDENSER WATER PUMPS	
25	REMARKS	-	-	
26	SPARES	-	FUSES & PROTECTIONS AS PER MANUFACTURER RECOMMENDATION	
27		-	-	
28	NOTES	-	-	
29	1) VFD KW RATING AS PER MANUFACTURER RECOMMENDATION FOR THE RATED MOTOR POWER.	-	-	
30	2) WIRING (100% SHIELDED CABLE) FROM VFD TO MOTOR	-	-	
31	3) VFD SHALL BE PROVIDED WITH EMC & RFI FILTERS AS PER EN 5501	-	-	
32	4) VFD SHALL BE PROVIDED WITH DC CHOKE	-	-	
33	5) VFD SHALL BE COMPATIBLE TO COMMUNICATE WITH BMS. THE COMMUNICATION PROTOCOL SHALL BE BACNET/MSTP.	-	-	
34	6) VFD SHALL BE PROVIDED WITH IP 55 PROTECTION CLASS	-	-	
35	7) VFD KW RATING SHOULD BE SELECTED ONE SIZE HIGHER THAN THE RATED MOTOR POWER TO ACCOUNT FOR DERATING OF THE VFDS DUE TO HIGH AMBIENT TEMPERATURE. EXPECTED AMBIENT TEMPERATURE IS 45 TO 48 °C	-	-	
36		-	-	
37	8) VFD TO BE PROVIDED WITH BUILT-IN PROTECTION AS MENTIONED IN THE SPECIFICATIONS. IF ADDITIONAL PROTECTION (AS PER MANUFACTURER RECOMMENDATION) IS REQUIRED, KINDLY INDICATE AND PROVIDE DETAILS.	-	-	
38		-	-	
39		-	-	
40		-	-	
41		-	-	
42		-	-	
43		-	-	
44		-	-	
45		-	-	
46		-	-	
47		-	-	
48		-	-	



REVISION	0	1
STATUS	ISSUED FOR TENDER	ISSUED FOR TENDER
DATE	17/10/2025	13/02/2026
CHECKED/SIGN	DANIAL ABDUL AZIZ	DANIAL ABDUL AZIZ
APPROVED	FAHAD ABDULLAH	FAHAD ABDULLAH

THE INFORMATION ON THIS DATA SHEET IS CONFIDENTIAL TO FAHIM, NANJI & DESOUZA (PVT.) LTD. AND SHALL NOT BE DISCLOSED TO A THIRD PARTY WITHOUT PRIOR WRITTEN PERMISSION



**SUI SOUTHERN GAS COMPANY LIMITED
TECHNICAL SPECIFICATIONS OF SADIMENT SEPARATOR**

SPECIFICATIONS

Equipment:	Sadiment Separator(Centrifugal separator)
Wall Thickness of body	10 mm
Water Pressure	1900 US GPM
Design Pressure	150 PSI
Préssure Drop	2.8 PSI
Inlet/ Outlet Size	10" Dia Flanged
Over All Height	118 inch
Shell Diameter	22 inch
Dry weight	520 Kg
<u>Feature</u>	Minimized water and chemical loss Extended component life Less maintenance Maximum system performance
Centrifugal Flow Pattern	Creates low pressure vortex in center of tank Lowers pressure drop through the tank
Manufacturing	Local Make
Warranty	1 year
QTY	1 No.



SUI SOUTHERN GAS COMPANY LIMITED
TECHNICAL SPECIFICATIONS OF CONDESER PUMP

SPECIFICATION CONDESER PUMP

Equipment:	CONDESER PUMP
PUMP TYPE	Centrifugal type: ETA 125-20
FLOW RATE CAPACITY	1900 US GPM
TOTAL HEAD	114 FT
SPEED	2900 RPM
NOMINAL DIAMETER SUCTION SIDE	6" (DN 150)
NOMINAL DIAMETER DISCHARGE SIDE	5" (DN 125)
FLANGE FACING TYPE INLET	RAISED FACE(B,RF)
FLANGE FACING TYPE OUTLET	RAISED FACE(B,RF)
IMPELLER DIA	205 MM
BEARING	Grease Lubricated
DESIGN	125 PSI/250 °F
LIQUID	Water
NPSH (Pump)	Specific Gravity: 1
PRIME MOVER	≥ 25 ft
<u>MATERIAL OF CONSTRUCTION</u>	SIEMENS ELECTRIC MOTOR
CASING	Cast Iron
IMPELLER	Bronze
SHAFT	Stainless Steel
SHAFT SEALING	Mechanical Seal
COUPLING Type	Pin-bush type
QTY	1 No.

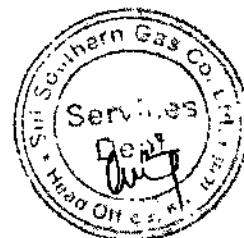

SUI SOUTHERN GAS COMPANY LIMITED
TECHNICAL SPECIFICATIONS OF MOTOR

ELECTRIC MOTOR

MOTOR TYPE

Totally Enclosed ,Fan Cooled,
Induction Motor

MOTOR POWER

80 HP / 60 kW / 3 Phase / 50 Hz

**RATED ROTATIONAL SPEED
MOTOR SPEED**

2970 RPM (2 Pole)

POWER

Commonly 400 VD/690 VY or 415 V

Duty Cycle:

S1 (Continuous Duty)

CONNECTION

Δ (Delta Star)

PRIME MOTOR

Siemens or Equivalent

VOLT

400/3/50

IP

55

Frame Size

225-250 around

NUMBER OF POLES

2-pole asynchronous squirrel-cage motor

INSULATION

Class F

FULL LOAD EFFIECENCY

93%

WEIGHT

570 KG

Frequency Control

Suitable for use with variable frequency drives (VFDs)

Frame Material:

cast iron

Efficiency

IE3

AMBIENT TEMPERATURE

50

QTY

1No.



SUI SOUTHERN GAS COMPANY LIMITED
TECHNICAL SPECIFICATIONS OF COOLING COIL FOR
AIR HANDLING UNIT Nos: 5 A (3 rd Floor)

SPECIFICATIONS:

Cooling Coil Size(without Steel frame/casing)	42" Height, 77.5" Length 9" - Width
Cooling Coil Face Area	23 Sq.-Ft
Cooling Coil Size(with Steel frame/casing)	45.6" Height, 81" Length 9" - Width
Color Inner Side	25 mm
Color Off Side	40 mm
Color Top Side	25 mm
Color bottom Side	50 mm
Coil Type	Chilled Water Circulation
Total Number of U-Band	??
Number of Rows	7
Coating Type	Weather Coated Rust Protection
Fins Material	Blue Hydro Dip Aluminum
Fins Spacing	14 (FPI)
Thickness of Fins	0.135 - 0.14 mm
Tube Material	Copper
Copper Tube diameter	5/8" Inch
Thickness of Tube	22 SWG (0.71 mm)
Origin of Copper Tube	Muller, USA or Equivalent
Casing Material	Galvanized Steel(14 gauge)
Header Connection	3" Inch In Copper / Brass with Flange of Inner dia 3"
Side Frame	4-Side GI 14 Gauge
Coil Tested	Pressurized with Nitrogen (300PSI)
Warranty	1 year
Quantity	01 Nos.

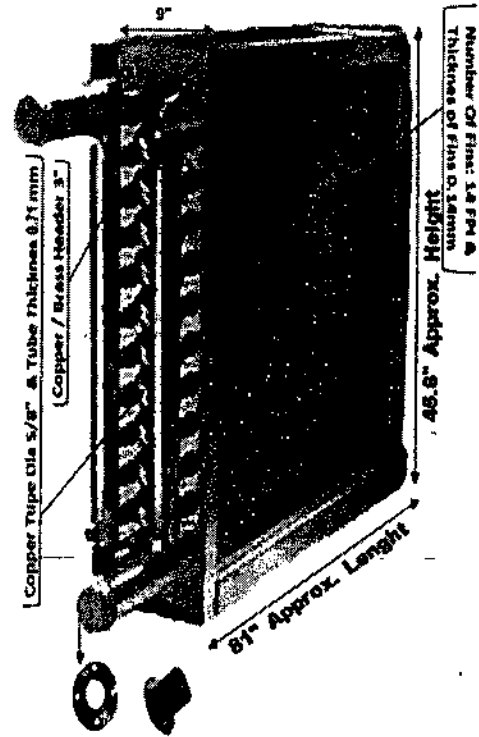

Welded Flange 3" inner dia with 4 hole at supply and return line



SUI SOUTHERN GAS COMPANY LIMITED
TECHNICAL SPECIFICATIONS OF COOLING COIL FOR
AIR HANDLING UNIT Nos: 4 (2nd Floor)

SPECIFICATIONS:

Cooling Coil Size(without Steel frame/casing)	54.3" Height, 90" Length 6.5" - Width
Cooling Coil Face Area	23 Sq.-Ft
Cooling Coil Size(with Steel frame/casing)	57" Height, 93" Length 6.5" - Width
Color Inner Side	25 mm
Color Off Side	40 mm
Color Top Side	25 mm
Color bottom Side	50 mm
Coil Type	Chilled Water Circulation
Total Number of U-Band	77
Number of Rows	7
Coating Type	Weather Coated Rust Protection
Fins Material	Blue Hydro Dip Aluminium
Fins Spacing	14 (FPI)
Thickness of Fins	0.135 - 0.14 mm
Tube Material	Copper
Copper Tube diameter	5/8 " inch
Thickness of Tube	22 SWG (0.71 mm)
Origin of Copper Tube	Muller, USA of Equivalent
Casing Material	Galvanized Steel(14 gauge)
Header Connection	3" Inch In Copper / Brass with Flange of Inner dia 3"
Side Frame	4-Side GI 14 Gauge
Coil Tested	Pressurized with Nitrogen (300PSI)
Warranty	1 year
Quantity	01 Nos.

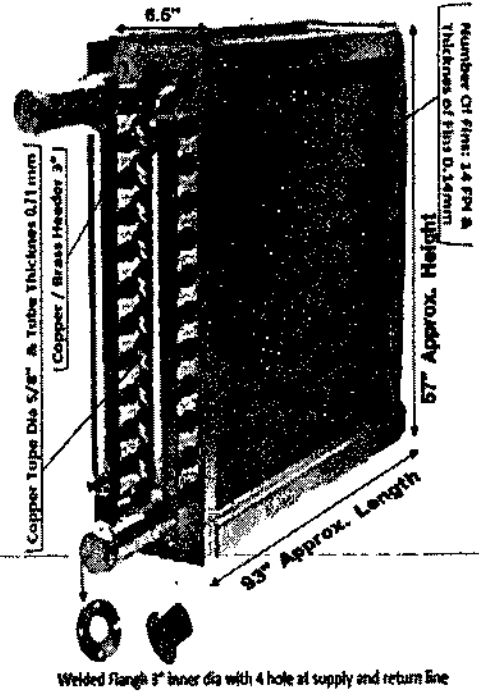

**SUI SOUTHERN GAS COMPANY LIMITED
TECHNICAL SPECIFICATIONS OF COOLING COIL FOR
AIR HANDLING UNIT Nos: 6 (4th Floor)**

SPECIFICATIONS:

Cooling Coil Size(without Steel frame/casing)	69" Height, 90" Length 12" - Width
Cooling Coil Face Area	43.13 Sq-Ft
Cooling Coil Size(with Steel frame/casing)	71" Height, 93" Length 12" - Width
Color Inner Side	40 mm
Color Off Side	60 mm
Color Top Side	15 mm
Color bottom Side	30 mm
U-Bend (Inside)	149 Nos
U-Bend (OFF Side)	201 Nos
Coil Type	Chilled Water Circulation
Total Number of U-Bend	350
Number of Rows	7
Coating Type	Weather Coated Rust Protection
Fins Material	Blue Hydro Dip Aluminum
Fins Spacing	14 (FPI)
Thickness of Fins	0.135 - 0.14 mm
Tube Material	Copper
Copper Tube diameter	5/8" Inch
Thickness of Tube	22 SWG (0.71 mm)
Origin of Copper Tube	Muller, USA or Equivalent
Casing Material	Galvanized Steel(14 gauge)
Header Connection	3" Inch In Copper / Brass with Flange of Inner dia 3"
Side Frame	4-Side GI 14 Gauge
Coil Tested	Pressurized with Nitrogen (300PSI)
Warranty	1 year
Quantity	01 Nos.

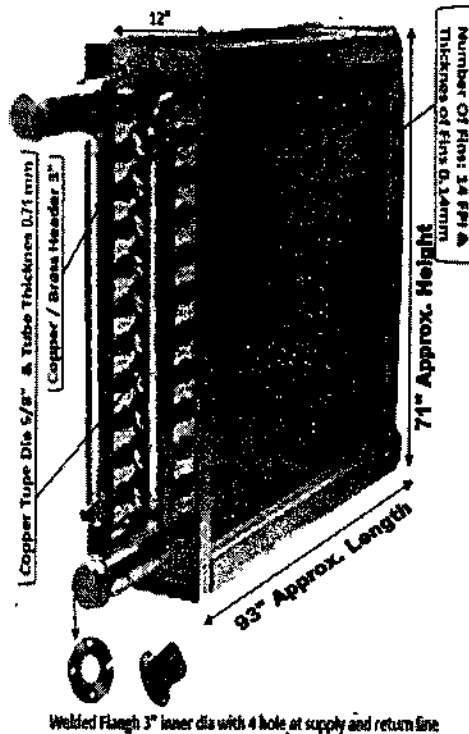



**SSGCL HEAD OFFICE BUILDING,
KARACHI**

Bill of Quantities

HVAC Works



Fahim, Nanji & deSouza (Pvt.) Ltd.
Consulting Engineers



PRICING PREAMBLES & INSTRUCTIONS

- a) The tenderers are required to fill in all sections of the BOQ, columns including all appendices. Tenderers not containing the above may be considered liable to rejection.
- b) All equipment proposed to be supplied shall be strictly from the "List of Approved Manufacturer" and supported by suitable manufacturer's catalogue/literature etc., with the model selected with make, origin and performance data clearly marked. Also submit quoted equipment capacities at specified conditions. Any deviation shall be clearly highlighted on separate sheets with columns of specified & proposed. If more than one source of supply of equipment/material is indicated by the tenderer, it is the Owner/Consultants discretion to choose the manufacturer of his own choice and not the discretion of the tenderer.
- c) All tenderers are advised to quote strictly as per specifications. Any alternative or deviations from specifications proposed shall be provided in the form of a separate quotation. Any tender not quoting as per specifications may be considered liable to rejection.
- d) All tenders shall be accompanied by one additional copy of the main proposal and the priced BOQ marked 'DUPLICATE', shall be returned duly filled.
- e) All specifications, drawings and other documents supplied by the Employer/Consultant for the purpose of bidding shall be returned with the tender bid with all pages duly stamped & signed. Tenderers unable to bid shall also return complete bid documents on the date of opening of the tender.
- f) The quantities set out in the BOQ are the estimated quantities of the work and they are not to be taken as the actual and correct quantities of the work to be executed by the Contractor in fulfillment of the Contract. The Contractor shall be required to supply and install everything necessary to provide a complete operational system as specified and shown on the drawings.
- g) All items mentioned in the Bill of Quantities (BOQ) consist of furnishing all plant, labour, equipment, appliances and materials required for completing the items/works in strict accordance with relevant specifications as described in the Contract Documents and Drawings.
- h) A price is to be entered against each item in the Bill of Quantities whether quantities are entered or not.
- i) Except as otherwise specifically provided for, all items in the Bill of Quantities are measured net, as fixed in place in accordance with the Drawings, and any allowance made for waste shall be included in the price rate for that item.
- j) General direction and descriptions of works and materials given in the details, Drawings and Specifications are not necessarily repeated in the Bill of Quantities. Reference is to be made by the tenderer to the details, Specifications and Drawings for their information and the same should be allowed for in their rates.
- k) In all cases where the Bill of Quantities items are not fully specific in respect of description or in respect of recommended manufacturers or suppliers, the tenderers attention are drawn to all the other tender documents including Specifications and Drawings.
- l) Generally the following shall be deemed to be included in the prices submitted with all items herein:
 - ◆ Labour and all cost in connection therewith, materials, goods and all costs in connection therewith including but not limited to, cartage, delivery, unloading, unpacking, returning packing, handling, hoisting to any height, lowering, octroi charges etc.
 - ◆ Erection, dismantling and removal on completion contractor's site offices, stores, accommodation.
 - ◆ General and other requirements of Specifications.
 - ◆ Installing, fitting and fixing goods and materials in positions.
 - ◆ Use of tools, plant and equipment.

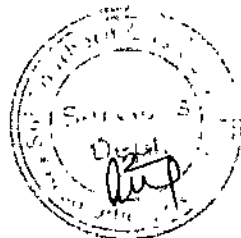

**SSGCL HEAD OFFICE BUILDING, KARACHI
HVAC WORKS**

**BILL OF QUANTITIES
DATED: APRIL 20, 2026**

- ◆ Waste of materials.
 - ◆ All necessary cutting, core cuts, structural and wall openings and make good to finishes.
 - ◆ All overheads and profits including Taxes.
 - ◆ Maintenance of work
- m) All references to design details within item's description shall be interpreted to mean that such items shall include all work necessary for completion of the items regardless of trade except where specifically described otherwise.
- n) This Bill of Quantities is to be read in conjunction with the Conditions of the Contract, Drawings and Specifications prepared by the Consultants/Project Managers, as being mutually explanatory.
- o) The attention of the tenderers is drawn to the fact that this Bill of Quantities is for use as a basis upon which the tenderers will calculate their tender costs. The tenderers should ensure for themselves the adequacy of the items, quantities and descriptions contained therein completely defining the scope of the work as shown in the Drawings and Specifications.
- p) Any discrepancies noticed by the tenderers between the Bill of Quantities, the intent of the Drawings and Specifications and the scope work, shall be brought to the attention of the Consultant/Engineer prior to submitting the tenders who shall notify their clarifications/decision to all the tenderers. No claims of whatsoever nature shall be admissible during or after the contract period for any misunderstandings, ambiguities due to above, which have not been notified to the Consultant/Engineer prior to submission of his priced tenders.
- q) Where special risks, liabilities and obligations cannot be dealt with as above, then the additional moneys required by the Tenderer to cover such special risks, liabilities and obligations are to be separately stated in a letter accompanying the Tender. Tenderer shall list each and every clause number from the Conditions of Contract and the Specification that they wish to price in this way, together with the price in the Tender. Any risk, obligation or liability arising from any clause of the Conditions of the Contract or the Specifications or from the works detailed on the Drawings which has not been specifically priced in the said letter of the Tenderer shall be deemed to be included in the billed prices.
- r) The tender documents include a soft copy with the BOQ formatted in MS Excel and include formulas to automatically generate additions & multiplications. Due care should be exercised in filling out. Tenders are required to submit their bid on the CD duly filled along with a hardcopy duly sealed & signed. The bidder shall also print the BOQ & paste it on the BOQ pages of the tender document & duly seal & sign every page. Handwritten BOQ shall not be accepted. No additions or deletion shall be made in the Excel sheet. If any corrections or additions are required, FND shall issue a new soft copy. If the tender wishes to make additions to the BOQ, he shall do so on a separate sheet, which shall be clearly marked "ADDITIONS TO THE BOQ BY BIDDER". All such pages shall also be pasted in the tender document, as well as a hardcopy shall be provided, duly sealed & signed.
- s) The BOQ requires the bidder to submit separate rates for "Material" and "Installation", and the two together make up the composite item rate. It shall however be understood that this division in no way implies that payment shall be made for delivery of material on site only. All payment to the Contractor is due on installation of the material in accordance with specifications and drawings, subject to the clause on "Secured Advance" (if specify) in Condition of Contracts.
- t) The Contract shall be an Item-Rate contract. *(Payment will be made on actual work performed & will be awarded on a package basis) (wop)*



BILL OF QUANTITIES

(1)	(2)	(3)	(4)	(5)	(6)	(7)	(8)	(9)	(10)
ITEM NO.	DESCRIPTION	QUANTITY	UNIT	RATE (Rs.)	AMOUNT (Rs.)	RATE (Rs.)	AMOUNT (Rs.)	RATE (Rs.)	AMOUNT (Rs.)
				(3) x (5)	(3) x (6)	(7) x (8)	(7) x (9)	(8) x (9)	(8) x (10)
1.0	ELECTRIC OPERATED WATER COOLED CENTRIFUGAL CHILLERS (SECTION 23 64 17 & DS/1890-23 64 17) (OWNER FURNISHED)								
1.1	Installation of Owner Furnished Electric Operated Water Cooled Centrifugal Chillers (CH/01 TO CH/02) (Section 23 64 26 & DS/1890H-23 64 26)	2	Nos.						
1.2	Supply & Installation of Foundation / Supports	1	Lot						
1.3	Installation of Owner Furnished Flow Switches	1	Lot						
1.4	Lifting/Shifting of all Chillers from Site Store to the location designated for Installation.	1	Lot						
1.5	Assistance in Commissioning & Testing	1	Lot						
	Sub-total Carried to Summary								
2.0	AIR HANDLING UNITS (SECTION 23 73 10 & DS/1890-23 73 10) (OWNER FURNISHED)								
2.1	Installation of Air Handling Unit (AHU/02) (Section 23 73 10 & DS/1890-23 73 10)	1	No.						
2.2	Supply & Installation of Foundation / Supports	1	Lot						
2.3	Supply & Installation of Flexible Duct Connector for AHUs	1	Lot						
2.5	Assistance in Commissioning & Testing	1	Lot						
	Sub-total Carried to Summary								
3.0	METER & GAUGES (SECTION 23 05 19)								
3.1	Thermometers Walls for Pipe Thermometer (Section 23 05 19)	10	Nos.						
3.2	Pipe Thermometers (Section 23 05 19)	10	Nos.						
3.3	Pressure Gauges on Pipes (Section 23 05 19)	10	Nos.						
3.4	Gauge Outlets with Cock (Section 23 05 19)	10	Nos.						
	Sub-total Carried to Summary								
4.0	PIPING (SECTION 23 21 13 & DS/1890-23 21 13)								
4.1	Chilled Water Piping		Rft						
4.1.1	Ø 10" (Ø 250mm)		Rft						
4.1.2	Ø 8" (Ø 200mm)	180	Rft						
4.1.3	Ø 6" (Ø 150mm)	20	Rft						
4.1.4	Ø 5" (Ø 125mm)		Rft						
4.1.5	Ø 4" (Ø 100mm)		Rft						
4.1.6	Ø 3" (Ø 75mm)	50	Rft						
4.1.7	Ø 2 1/2" (Ø 65mm)		Rft						
4.1.8	Ø 2" (Ø 50mm)		Rft						
4.2	Pipe Supports as per as per Engineered Support System	1	Lot						
4.3	Pipe Pressure Testing		Lot						
4.4	Condenser Water Piping		Rft						
4.4.1	Ø 12" (Ø 300mm)		Rft						
4.4.2	Ø 10" (Ø 250mm)	320	Rft						
4.4.3	Ø 8" (Ø 200mm)	30	Rft						
4.5	Pipe Supports as per as per Engineered Support System	1	Lot						
4.6	Pipe Pressure Testing		Lot						
	Sub-total Carried to Summary								
5.0	VALVES & SPECIALITIES (SECTION 23 05 23, 23 21 13, 23 06 20 & 23 06 35)								
5.1	Supply and Installation of Butterfly Valves with Material/Flanges/Unions etc (Section 23 05 23)	2	No.						
5.1.1	Ø 14" (Ø 350mm)		No.						
5.1.1	Ø 12" (Ø 300mm)		No.						



88GCL HEAD OFFICE BUILDING, KARACHI
HVAC WORKS

BILL OF QUANTITIES
DATED: APRIL 20, 2026

BILL OF QUANTITIES

(1)	(2)	(3)	(4)	(5)	(6)	(7)	(8)	(9)	(10)
ITEM NO.	DESCRIPTION	ESTIMATED QUANTITY	UNIT	RATE (Rs.)	MATERIALS AMOUNT (Rs.)	INSTALLATION RATE (Rs.)	AMOUNT (Rs.)	TOTAL RATE (Rs.)	TOTAL AMOUNT (Rs.)
				(3) x (4)	(5) x (6)	(7) x (8)	(5) + (7)	(8) + (9)	(8) + (10)
5.1.2	Ø 10" (Ø 250mm)	8	Nos.						
5.1.3	Ø 8" (Ø 200mm)	10	Nos.						
5.1.4	Ø 6" (Ø 150mm)	2	Nos.						
5.1.5	Ø 5" (Ø 125mm)	-	No.						
5.1.6	Ø 4" (Ø 100mm)	-	No.						
5.1.7	Ø 3" (Ø 75mm)	2	Nos.						
5.1.8	Ø 2 1/2" (Ø 65mm)	1	No.						
5.1.9	Ø 2" (Ø 50mm)	-	No.						
5.2	Supply and Installation of Gate Valves with Material/Flanges/Unions etc (Section 23 05 23)								
5.2.1	Ø 2 1/2" (Ø 65mm)	-	No.						
5.2.2	Ø 2" (Ø 50mm)	-	No.						
5.2.3	Ø 1 1/2" (Ø 40mm)	-	No.						
5.2.4	Ø 1 1/4" (Ø 32mm)	-	No.						
5.2.5	Ø 1" (Ø 25mm)	-	No.						
5.3	Supply and Installation of Ball Valve with Material/Flanges/Unions etc (Section 23 05 23)								
5.3.1	Ø 3" (Ø 75mm)	-	No.						
5.3.2	Ø 1 1/2" (Ø 40mm)	-	No.						
5.3.3	Ø 1 1/4" (Ø 32mm)	-	No.						
5.3.4	Ø 1 1/2" (Ø 32mm)	-	No.						
5.3.5	Ø 1" (Ø 25mm)	4	No.						
5.4	Supply and Installation of Flexible Connector with Material/Flanges/Unions etc (Section 23 05 13)								
5.4.1	Ø 1 1/4" (Ø 30mm)	-	No.						
5.4.2	Ø 1 1/2" (Ø 30mm)	-	No.						
5.4.3	Ø 1" (Ø 250mm)	4	Nos.						
5.4.4	Ø 8" (Ø 200mm)	4	Nos.						
5.4.5	Ø 6" (Ø 150mm)	-	No.						
5.4.6	Ø 5" (Ø 125mm)	-	No.						
5.4.7	Ø 4" (Ø 100mm)	2	Nos.						
5.4.8	Ø 3" (Ø 75mm)	-	No.						
5.4.9	Ø 2 1/2" (Ø 65mm)	-	No.						
5.4.10	Ø 2" (Ø 50mm)	-	No.						
5.5	Supply and Installation of Flow Balancing & Shut off Valve with Material/Flanges/Unions etc (Section 23 06 20)								
5.5.1	Ø 12" (Ø 300mm)	-	No.						
5.5.2	Ø 10" (Ø 250mm)	2	Nos.						
5.5.3	Ø 8" (Ø 200mm)	2	Nos.						
5.5.4	Ø 6" (Ø 150mm)	-	No.						
5.5.5	Ø 5" (Ø 125mm)	-	No.						
5.5.6	Ø 4" (Ø 100mm)	-	No.						
5.5.7	Ø 3" (Ø 75mm)	1	No.						
5.5.8	Ø 2 1/2" (Ø 65mm)	-	No.						
5.5.9	Ø 2" (Ø 50mm)	-	No.						

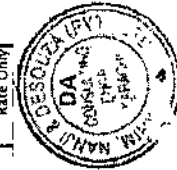
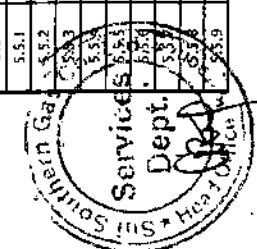

Fahim, Nanji & deSouza (Pvt.) Ltd.
Consulting Engineers

260420-FND-1890-TD-H-XX-BOQ-001_BOQ HVAC Local Works

BILL OF QUANTITIES

ITEM NO.	DESCRIPTION	ESTIMATED QUANTITY	UNIT	MATERIAL		INSTALLATION		TOTAL	
				RATE (Rs.)	AMOUNT (Rs.)	RATE (Rs.)	AMOUNT (Rs.)	RATE (Rs.)	AMOUNT (Rs.)
5.6	Supply and Installation of Strainer with Ball Valve & Material/Flanges/Unions etc (Section 23.85.20)		No.		Rate Only		Rate Only		Rate Only
5.6.1	Ø 3" (Ø 75mm)	1	No.		Rate Only		Rate Only		Rate Only
5.6.2	Ø 2 1/2" (Ø 65mm)	-	No.		Rate Only		Rate Only		Rate Only
5.6.3	Ø 2" (Ø 50mm)	-	No.		Rate Only		Rate Only		Rate Only
5.6.4	Ø 1 1/2" (Ø 40mm)	-	No.		Rate Only		Rate Only		Rate Only
5.6.5	Ø 1 1/4" (Ø 32mm)	-	No.		Rate Only		Rate Only		Rate Only
5.6.6	Ø 1" (Ø 25mm)	-	No.		Rate Only		Rate Only		Rate Only
5.7	Supply and Installation of Automatic Air vent with Ball valve & Material/Flanges/Unions etc (Section 23.85.20)		No.		Rate Only		Rate Only		Rate Only
5.7.1	Ø 1 1/2" (Ø 32mm)	-	No.		Rate Only		Rate Only		Rate Only
5.7.2	Ø 1" (Ø 25mm)	-	No.		Rate Only		Rate Only		Rate Only
5.7.3	Ø 3/4" (Ø 20mm)	2	Nos.		Rate Only		Rate Only		Rate Only
Sub-total Carried to Summary									
6.0	THERMAL INSULATION & CLADDING (SECTION 23.07.19 & DS/1890-23.07.19)								
6.1	Chilled Water Piping Insulation including Vapor Barrier, Jacketing & Cladding (Section 23.07.19 & DS/1890-23.07.19)		Rft		Rate Only		Rate Only		Rate Only
6.1.1	Ø 12" (Ø 300mm)	-	Rft		Rate Only		Rate Only		Rate Only
6.1.2	Ø 10" (Ø 250mm)	180	Rft		Rate Only		Rate Only		Rate Only
6.1.3	Ø 8" (Ø 200mm)	20	Rft		Rate Only		Rate Only		Rate Only
6.1.4	Ø 6" (Ø 150mm)	-	Rft		Rate Only		Rate Only		Rate Only
6.1.5	Ø 5" (Ø 125mm)	-	Rft		Rate Only		Rate Only		Rate Only
6.1.6	Ø 4" (Ø 100mm)	50	Rft		Rate Only		Rate Only		Rate Only
6.1.7	Ø 3" (Ø 75mm)	-	Rft		Rate Only		Rate Only		Rate Only
6.1.8	Ø 2 1/2" (Ø 65mm)	-	Rft		Rate Only		Rate Only		Rate Only
6.1.9	Ø 2" (Ø 50mm)	-	Rft		Rate Only		Rate Only		Rate Only
6.2	Cladding of valves & Specialities (Operable boxes with insulation) (Section 23.07.19 & DS/1890-23.07.19)		No.		Rate Only		Rate Only		Rate Only
6.2.1	Ø 12" (Ø 300mm)	-	No.		Rate Only		Rate Only		Rate Only
6.2.2	Ø 10" (Ø 250mm)	10	Nos.		Rate Only		Rate Only		Rate Only
6.2.3	Ø 8" (Ø 200mm)	2	Nos.		Rate Only		Rate Only		Rate Only
6.2.4	Ø 6" (Ø 150mm)	-	No.		Rate Only		Rate Only		Rate Only
6.2.5	Ø 5" (Ø 125mm)	-	No.		Rate Only		Rate Only		Rate Only
6.2.6	Ø 4" (Ø 100mm)	4	Nos.		Rate Only		Rate Only		Rate Only
6.2.7	Ø 3" (Ø 75mm)	1	No.		Rate Only		Rate Only		Rate Only
6.2.8	Ø 2 1/2" (Ø 65mm)	-	No.		Rate Only		Rate Only		Rate Only
6.2.9	Ø 2" (Ø 50mm)	-	Nos.		Rate Only		Rate Only		Rate Only
6.2.10	Ø 1 1/2" (Ø 40mm)	-	Nos.		Rate Only		Rate Only		Rate Only
6.2.11	Ø 1 1/4" (Ø 32mm)	2	No.		Rate Only		Rate Only		Rate Only
6.2.12	Ø 1" (Ø 25mm)	-	No.		Rate Only		Rate Only		Rate Only
6.2.13	Ø 3/4" (Ø 20mm)	-	No.		Rate Only		Rate Only		Rate Only
Sub-total Carried to Summary									
7.0	SUPPLY & INSTALLATION OF DUCT WORK (MACHINE MADE) (SECTION 23.31.13)								
7.1	Sheet Metal Duct Work (Air Conditioning) (Supply/Return), Machine made Ducts (Section 23.31.13)	1080	sq.ft		Rate Only		Rate Only		Rate Only
7.2	Sheet Metal Duct Work (Fresh Air) Machine made Ducts (Section 23.31.13)	320	sq.ft		Rate Only		Rate Only		Rate Only
7.3	Quadrant Volume Dampers	-	sq.ft		Rate Only		Rate Only		Rate Only

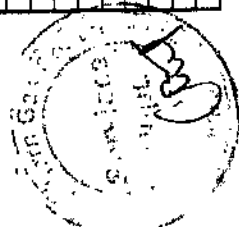

BILL OF QUANTITIES

(1) ITEM NO.	(2) DESCRIPTION	(3) ESTIMATED QUANTITY	(4) UNIT	(5) MATERIAL		(6) INSTALLATION		(7) TOTAL	
				AMOUNT (Rs.)	(3) x (5)	RATE (Rs.)	AMOUNT (Rs.)	RATE (Rs.)	(6) + (7)
13.0 AUTOMATIC CONTROL SYSTEM (SECTION 23 09 20 & DS1890-23 09 20)									
13.1	Controls for Chilled Water Plant	1	Lot						
13.1.1	Field Device: IP Based DDC Controller	2	Nos.						
13.1.2	Communication with Chiller Control Panel	8	Nos.						
13.1.3	Field Device: PT-1000 Pipe temperature sensor with brass wells	2	Nos.						
13.1.4	Field Device: Water Flow Switch (For Chilled Water Application)	1	No.						
13.1.5	Field Device: Outdoor Temperature & Humidity Sensor	1	Lot						
13.2	Controls for AHU	2	Nos.						
13.2.1	Field Device: IP Based DDC Controller	2	Nos.						
13.2.2	Field Device: PT-1000 temperature sensor with brasswells (For Chilled & Hot Water Application)	3	Nos.						
13.2.3	Field Device: Air duct temperature sensors. Prewired and terminal block versions shall be available to mount in and outside the duct. Temperature range shall be -40 to +120°C	1	Nos.						
13.2.4	Field Device: 2-Way Motorized Control Valve. Modulating proportional valve actuator with reversible synchronous motor 0-10 VDC. (For Chilled Water Application)	3	Nos.						
13.2.5	Field Device: Differential Pressure Switch (DPS) with pressure adjustment range of .5 to 4 mbar and switching difference of 0.2 mbar or less	1	Nos.						
13.2.6	Field Device: Relative Humidity Sensor	1	Nos.						
13.2.7	Field Device: CO ₂ Sensor	1	Nos.						
13.2.8	Field Device: Fire Stat	1	No.						
13.2.9	Field Device: Outdoor Temperature & Humidity Sensor	1	Lot						
13.3	Miscellaneous								
13.3.1	Complete Control & Power Cabling for above systems	1	Lot						
13.3.2	Supply of Supports, Hangers, Sleeves, Core Drilling etc.	1	Lot						
13.3.3	As Built Drawings	1	Lot						
13.3.4	Shop Drawings with Complete Control Logics	1	Lot						
13.3.5	Integration of New Chiller with the Existing chillers.	1	Lot						
13.3.6	Integration of New Chiller with the fire Alarm.	1	Lot						
				Sub-total Carried to Summary					
				Sub-total Carried to Summary					
14.0 SUPPLY & INSTALLATION OF VARIABLE FREQUENCY DRIVES (SECTION 23 87 20 & DS1890-23 87 20)									
14.1	Variable Frequency Drive (VFD/P/ 01-03) with RFI Filter & Communication Card (Section 23 87 20 & DS1890-23 87 20)	3	Nos.						
14.2	Variable Frequency Drive (VFD/P/ 06-08) with RFI Filter & Communication Card (Section 23 87 20 & DS1890-23 87 20)	3	Nos.						
14.3	Commissioning & Testing								
				Sub-total Carried to Summary					
15.0 TEST RUN COORDINATION WITH O&M STAFF OF THE PLANT (SECTION 23 05 94)									
15.1	One Month Test Run coordination with O&M Staff	1	Lot						
				Sub-total Carried to Summary					
16.0 OBSERVATION ROOM WORKS									
16.1	Structural Framework	1	Lump Sum						
16.2	Existing concrete pillar preparation: surface cleaning, drilling, anchoring, and connection brackets (Includes fire-rated anchors and sealant)	3	Nos.						
16.3	Aluminum box pillars: 4" x 4" x 16' (101.6 x 101.6 x 3 mm) extruded 6063-T6. Full height (8 ft) (Includes base plates, anchor bolts, and top connection plates)	1	Lump Sum						
16.4	Aluminum perimeter header / ring beam: custom fabricated channels to the pillars and support roof & glazing (Extruded or welded aluminum, sized per structural requirements)	1	Lump Sum						

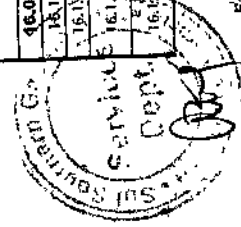

BILL OF QUANTITIES

(1) ITEM NO.	(2) DESCRIPTION	(3) ESTIMATED QUANTITY	(4) UNIT	(5) MATERIAL		(7) INSTALLATION		(10) TOTAL	
				RATE (Rs.)	AMOUNT (Rs.)	RATE (Rs.)	AMOUNT (Rs.)	RATE (Rs.)	AMOUNT (Rs.)
				(5) * (4)	(6) * (4)	(7) * (4)	(8) * (4)	(9) * (4)	(10) * (4)
16.2	Knee Wall (3 ft high)	110	Sq.ft						
16.2.1	Fire-retardant sandwich panels (mineral wool core, 50 mm thick) with aluminum facings (Estimated perimeter area minus door opening and pillar face)	1	Lump Sum						
16.2.2	Aluminum Z-furring or sub-girts for panel attachment.	1	Lump Sum						
16.3	Glazing System	280	Sq.ft						
16.3.1	Double-glazed acoustic units (6.38mm laminated + 12mm air + 6mm tempered), STC ≥ 40 (Total glass area above knee wall (adjusted for door and pillar	1	Lump Sum						
16.3.2	Aluminum glazing profiles (pressure plate, gaskets, and structural silicone) (Thermally broken profiles recommended)	1	Lump Sum						
16.4	Roof System	120	Sq.ft						
16.4.1	Fire-retardant aluminum-GFRP composite roof panels, 40 mm thick, Class A fire rating (10' x 12' roof area. Includes panel joints, sealants, and flashing	1	Lump Sum						
16.4.2	Aluminum roof substructure (C-purlin or tube grid) (Bolted connection to pillars and concrete pillar)	1	Lump Sum						
16.5	Door	1	No.						
16.5.1	Acoustic double-glazed aluminum door, 2.5' x 7', with drop seal, hinges, lock, and frame (Flush-mount against concrete pillar)	1	Lump Sum						
16.6	Fire Protection	1	Lump Sum						
16.6.1	Intumescent coating for aluminum structural members (pillars, headers) (30-minute fire rating)	1	Lump Sum						
16.6.2	Fire-rated acoustic sealant for all joints (floor, pillar, wall, ceiling)	1	Lump Sum						
16.7	Finishes & MEP	120	Sq.ft						
16.7.1	Floor preparation: self-leveling compound + anti-static epoxy coating. (Or raised floor if specified).	1	Lump Sum						
16.7.2	Interior trims, corner beads, and finishing profiles.	1	Lump Sum						
16.7.3	Coordination of MEP penetrations (sleeves, fire-stopping) (Electrical, data, HVAC)	1	Lump Sum						
16.8	Electrical Outlets and Lighting	1	Lump Sum						
16.8.1	Dimmable 2'x2' LED Panel of 4000K (Daylight) color with appropriate control board as indicated in the drawings (LED Panel)	1	Lump Sum						
16.8.2	Electric Power outlets as indicated in the drawings (Power Outlets)	1	Lump Sum						
16.9	Electrical Outlets and Lighting	1	Lump Sum						
16.9.1	Supply, installation and commissioning of 1 Kton Inverter air conditioner of durable and reputable brand in the Control room and mounting the indoor unit at appropriate placing without disturbing the vision of equipment (Split Air Conditioner)	1	Lump Sum						
16.10	Installation & Logistics	1	Lump Sum						
16.10.1	Full installation labor (assembly, welding/bolting, glazing, sealing, finishing).	1	Lump Sum						
16.10.2	Transportation and lifting (if required for basement access).	1	Lump Sum						
				Sub-total Carried to Summary					
17.0	TOOLS AND INSTRUMENTS (SECTION 23 89 10)								
17.1	Instruments	1	Lot						
17.2	Tools	1	Lot						
				Sub-total Carried to Summary					
18.0	MISCELLANEOUS								
18.1	Shop Drawings	1	Lot						
18.2	As Built Drawings	1	Lot						
18.3	Operation & Maintenance Manuals	1	Lot						
18.4	Structural Openings, Core Cuts & Pipe Sleeves	1	No.						
18.5	Supply and Installation of Sediment Separators	1	No.						
18.6	Installation of Owner furnished Sediment Separators	1	No.						
18.7	Centrifugal Condenser Pump only (Only Supply)	1	No.						
18.8	Centrifugal Condenser Motor Only (Only Supply)	1	No.						

Handwritten signature and stamp area.



**SSGC HEAD OFFICE BUILDING, KARACHI
HVAC WORKS**

**BILL OF QUANTITIES
DATED: APRIL 20, 2026**

BILL OF QUANTITIES

(1)	(2)	(3)	(4)	(5)	(6)	(7)	(8)	(9)	(10)
ITEM NO.	DESCRIPTION	ESTIMATED QUANTITY	UNIT	MATERIAL RATE (Rs.) (3) * (5)	INSTALLATION RATE (Rs.) (3) * (7)	TOTAL RATE (Rs.) (5) + (7)	MATERIAL AMOUNT (Rs.) (3) * (5)	INSTALLATION AMOUNT (Rs.) (3) * (7)	TOTAL AMOUNT (Rs.) (5) + (7)
18.9	Supply of Air Handling Unit Cooling Coils	1	Lot		Rate Only				
18.9.1	Supply of Cooling Coil of AHU / SA (3rd Floor)	1	Lot		Rate Only				
18.9.2	Supply of Cooling Coil of AHU / 04 (2nd Floor)	1	Lot		Rate Only				
18.9.3	Supply of Cooling Coil of AHU / 06 (4th Floor)	1	Lot		Rate Only				
18.10	Removal of Existing Equipment / Material Not in Use								
18.10.1	Removal of Sediment Separators	2	No.						
18.10.2	Sheet Metal Duct Work (Air Conditioning) (Supply/Return/Exhaust Air), Machine made Ducts (Section 23 31 13)	1150	sq.ft						
18.10.3	Dismantling of Existing HVAC & Electrical System/material that will not remain in use	1	Lot						
18.10.4	Dismantling of Existing Thermal Storage, Heat Exchanger, Its foundation and associated pipings	1	Lot						
		Sub-total Carried to Summary							



Fahim, Nanji & deSouza (Pvt.) Ltd.
Consulting Engineers

260420-FND-1890-TD-H-XX-BOQ-001_BOQ HVAC Local Works



**SSGCL HEAD OFFICE BUILDING,
KARACHI**

Drawings

HVAC Works



Fahim, Nanji & deSouza (Pvt.) Ltd.
Consulting Engineers



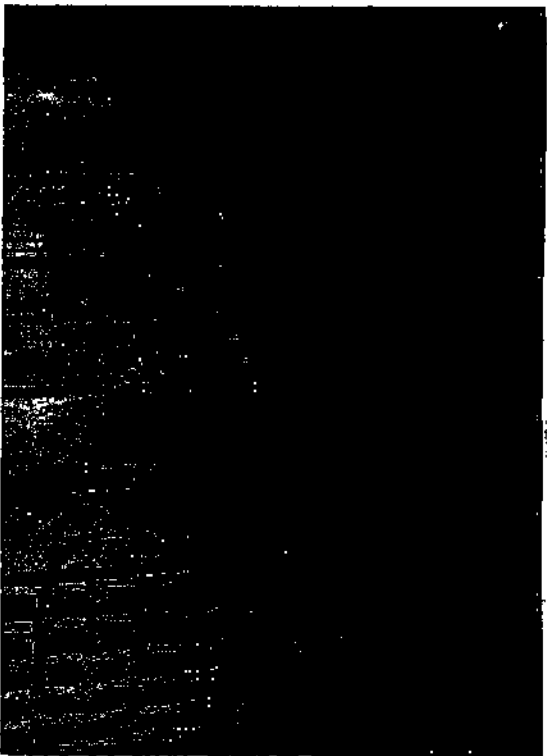

**SSGCL HEAD OFFICE
BUILDING, KARACHI
HVAC WORKS
ISSUED FOR TENDER
APRIL, 2026
(REV-01)**

CLIENT

SUI SOUTHERN GAS COMPANY LIMITED
ST-48 HASSAN SQUARE EYOVER
BLOCK 14 EDL SHAN-BIQHAL, KARACHI, 75300

M/E/C CONSULTANT



FAHIM, NANJI & DESOUZA (Pvt) Ltd
Consulting Engineers
HVAC, Plumbing, Mechanical & Electrical
4th Floor, ILACO House, State Life Building-5, Adb
Karachi-74400 Pakistan
Ph: +9221 3503 7816 - 02
Email: mechanical@fnd.com.pk
Email: erc@fnd.com.pk
Web Site: www.fnd.com.pk





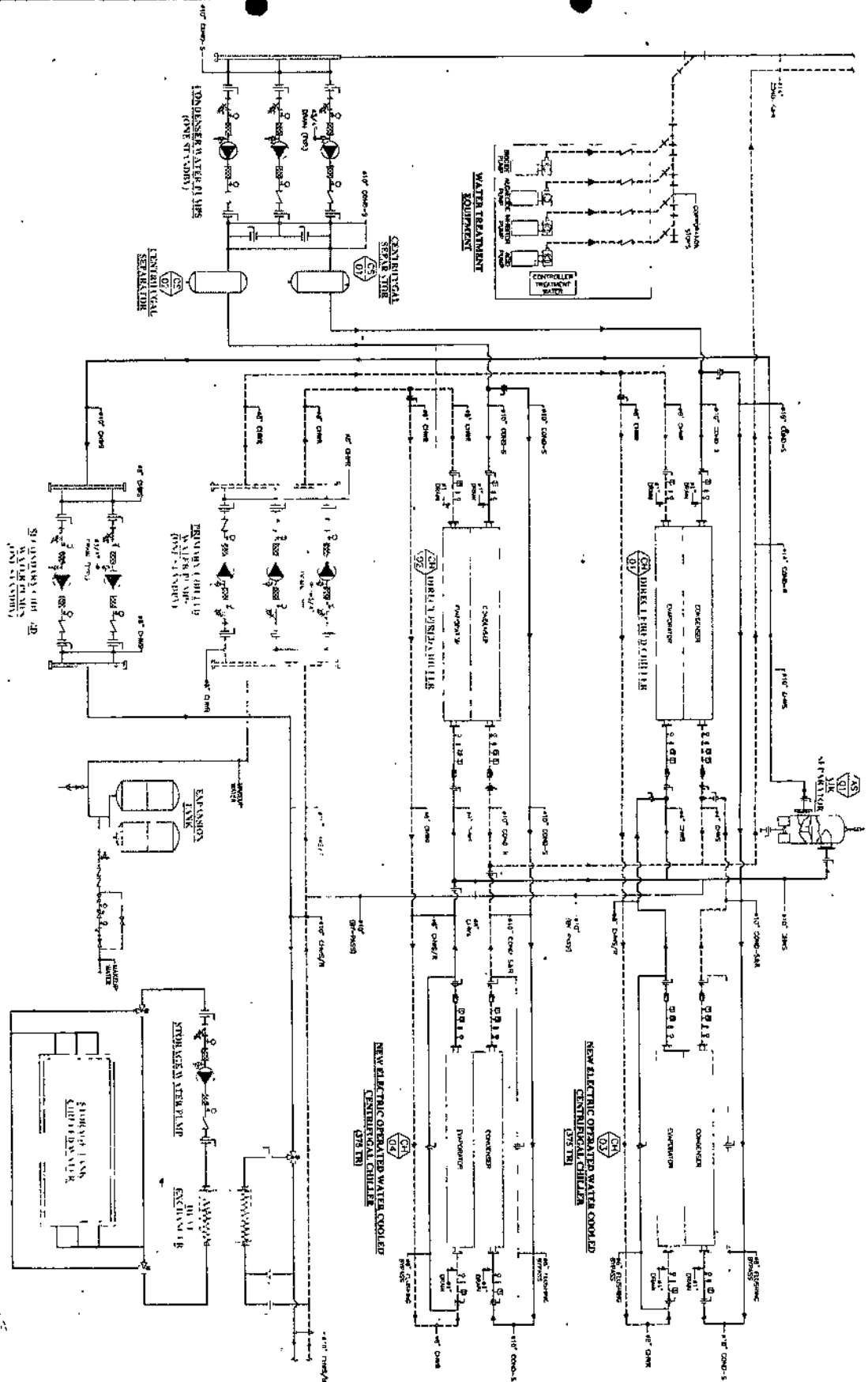

The drawings are the property of Sindh Electric & Water Corporation. No part of these drawings may be reproduced or stored in a retrieval system without the prior written permission of the Corporation.

LEGEND

SYMBOLS	DESCRIPTION
	BALL VALVE
	GATE VALVE
	CHECK VALVE
	FLANGED CONNECTION
	STEAM PIPE
	FLANGE
	TEE
	ELBOW
	PIPE
	TEMPERATURE GAUGE
	PRESSURE GAUGE
	FLOW SWITCH
	TEMPERATURE SENSOR
	EXISTING CHILLED WATER SUPPLY PIPE
	EXISTING CHILLED WATER RETURN PIPE
	EXISTING CONDENSER WATER SUPPLY PIPE
	EXISTING CONDENSER WATER RETURN PIPE
	NEW CHILLED WATER SUPPLY PIPE
	NEW CHILLED WATER RETURN PIPE
	NEW CONDENSER WATER SUPPLY PIPE
	NEW CONDENSER WATER RETURN PIPE
	CHILLED WATER SUPPLY PIPE
	CHILLED WATER RETURN PIPE
	CONDENSER WATER SUPPLY PIPE
	CONDENSER WATER RETURN PIPE

Sindh Electric & Water Corporation
 SSSC
 Sindh Electric & Water Corporation Limited
 Sindh Electric & Water Corporation
 Sindh Electric & Water Corporation

SSCL HEAD OFFICE
 BUILDING, KARACHI
 CONSULTANT: **CAHILL, NAINI & DESOZAI (PVT) LTD**
 11/11/1970
 PND

CHILLED & CONDENSER WATER
 SCHEMATIC DRAWING

11 PND-1504-D









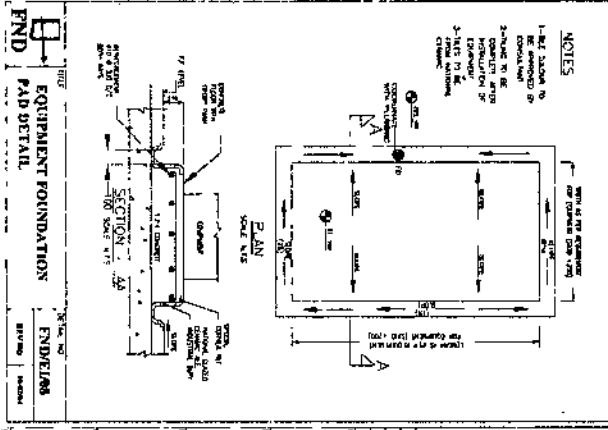
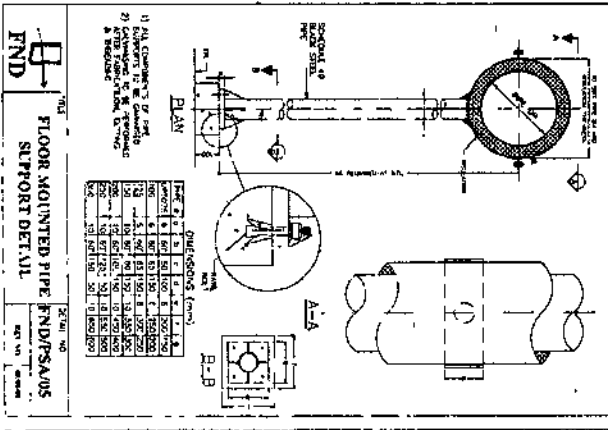
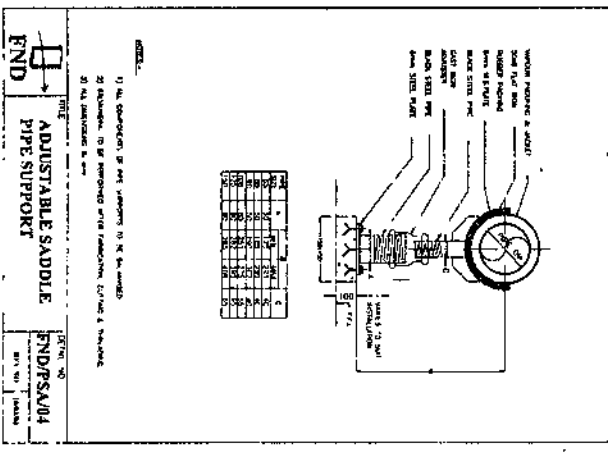
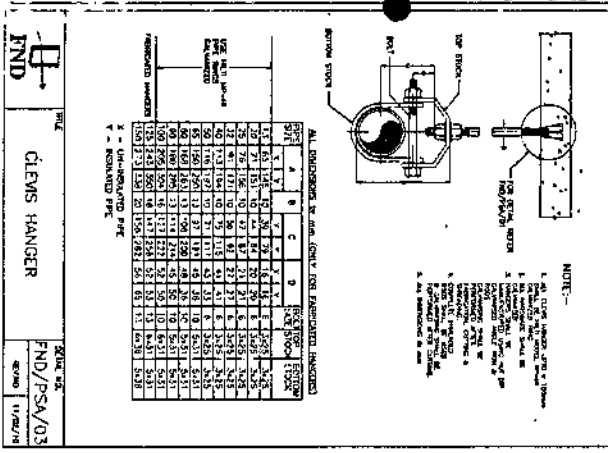
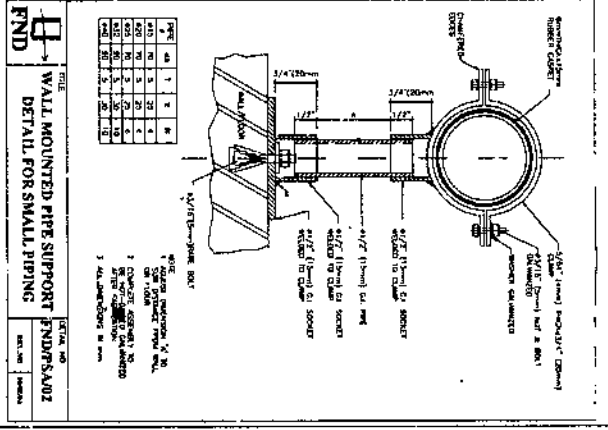
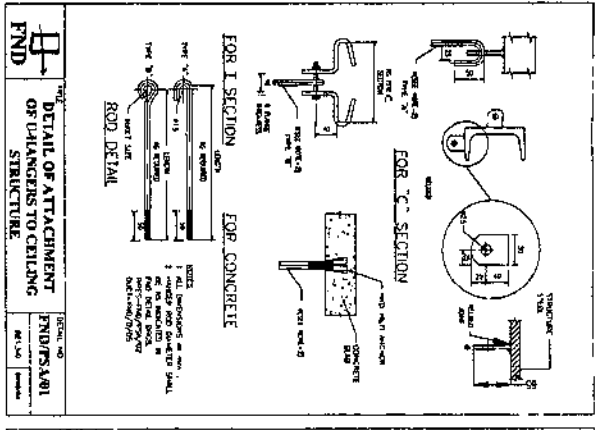
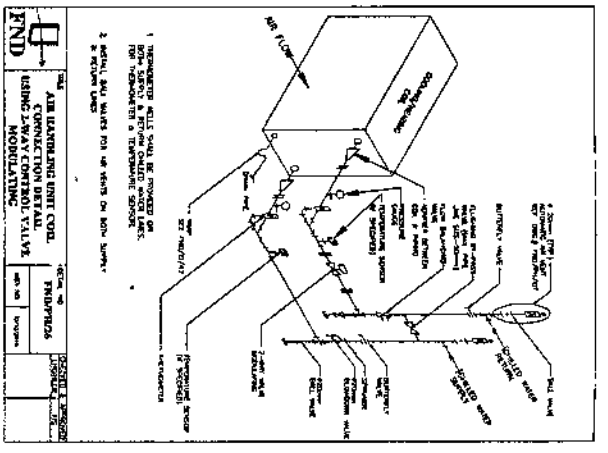
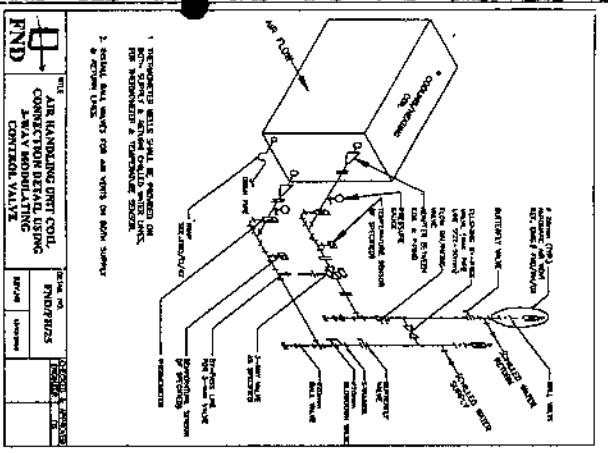

TITLE STANDARD DETAIL (SHEET-03)

SECTION NO. END/PSA/03

DATE 11/20/21

SCALE 1/2" = 1'-0"

REVISIONS

1. ALL DIMENSIONS IN mm. SHALL BE AS SHOWN. IF NOT SHOWN, REFER TO THE DRAWING NOTES.

2. ALL DIMENSIONS IN mm.

3. ALL DIMENSIONS IN mm.

PROJECT FARIM, NANJI & DESOJIA (PVT) Ltd
CONTRACT Farim, Nanji & Desoija (Pvt) Ltd
ADDRESS Farim, Nanji & Desoija (Pvt) Ltd
DATE 11/20/21

DESIGNED BY [Signature]
CHECKED BY [Signature]
DATE 11/20/21

SCALE 1/2" = 1'-0"

REVISIONS

1. ALL DIMENSIONS IN mm. SHALL BE AS SHOWN. IF NOT SHOWN, REFER TO THE DRAWING NOTES.

2. ALL DIMENSIONS IN mm.

3. ALL DIMENSIONS IN mm.

DA FARIM, NANJI & DESOJIA (PVT) LTD
CONSULTING ENGINEERS
KARACHI

1. ALL DIMENSIONS IN mm. SHALL BE AS SHOWN. IF NOT SHOWN, REFER TO THE DRAWING NOTES.

2. ALL DIMENSIONS IN mm.

3. ALL DIMENSIONS IN mm.

4. ALL DIMENSIONS IN mm.

5. ALL DIMENSIONS IN mm.

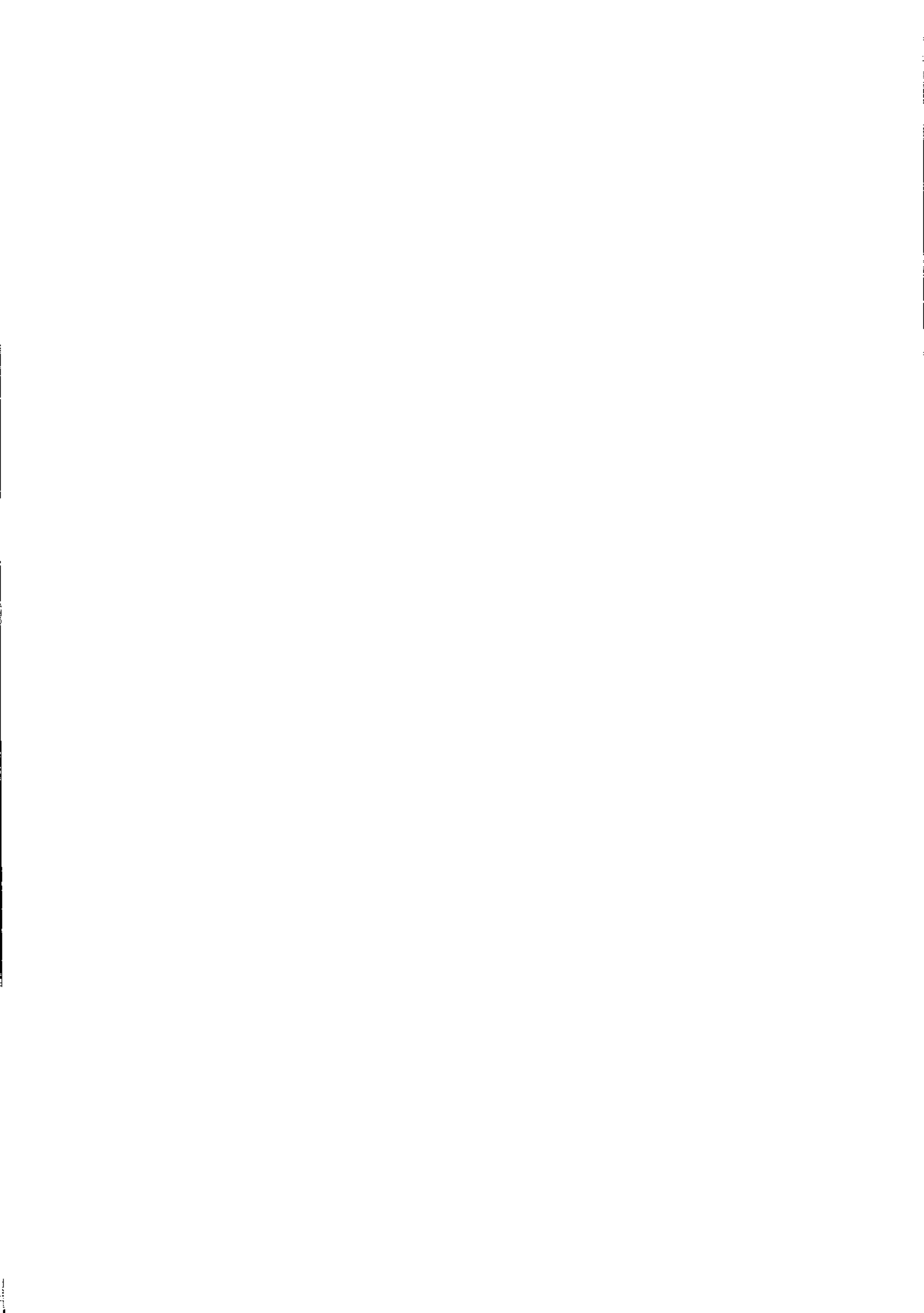

The drawings & the products of these items & should not be used for any other purpose without the written consent of the Engineer. The Engineer is not responsible for any damage or loss of any kind which may be incurred by the use of these drawings without the written consent of the Engineer.

<p>FND</p> <p>CHILLER FOUNDATION PAD DETAIL</p>	<p>NOTES</p> <ol style="list-style-type: none"> 1- THE FOUNDATION TO BE CONSTRUCTED IN ACCORDANCE WITH THE SPECIFICATIONS. 2- ALL DIMENSIONS TO BE IN METERS UNLESS OTHERWISE SPECIFIED. 3- ALL DIMENSIONS TO BE TO FACE UNLESS OTHERWISE SPECIFIED. 4- ALL DIMENSIONS TO BE TO CENTERLINE UNLESS OTHERWISE SPECIFIED. 5- ALL DIMENSIONS TO BE TO THE CENTERLINE OF THE CHILLER UNLESS OTHERWISE SPECIFIED. 6- ALL DIMENSIONS TO BE TO THE CENTERLINE OF THE FOUNDATION UNLESS OTHERWISE SPECIFIED.
<p>FND</p> <p>CHILLER FOUNDATION PAD DETAIL</p>	<p>NOTES</p> <ol style="list-style-type: none"> 1- THE FOUNDATION TO BE CONSTRUCTED IN ACCORDANCE WITH THE SPECIFICATIONS. 2- ALL DIMENSIONS TO BE IN METERS UNLESS OTHERWISE SPECIFIED. 3- ALL DIMENSIONS TO BE TO FACE UNLESS OTHERWISE SPECIFIED. 4- ALL DIMENSIONS TO BE TO CENTERLINE UNLESS OTHERWISE SPECIFIED. 5- ALL DIMENSIONS TO BE TO THE CENTERLINE OF THE CHILLER UNLESS OTHERWISE SPECIFIED. 6- ALL DIMENSIONS TO BE TO THE CENTERLINE OF THE FOUNDATION UNLESS OTHERWISE SPECIFIED.
<p>FND</p> <p>DETAIL FOR AIR HANDLING UNIT</p>	
<p>FND</p> <p>CLOSED EXPANSION TANK</p>	
<p>FND</p> <p>PIPE & CONTROLS WIRING ARRANGEMENT WITH CONTRACTOR'S PASS CIRCUIT</p>	

<p>FND</p> <p>PIPE AND FITTINGS INSTALLATION CLADDING DETAIL</p>	
<p>FND</p> <p>DUCT INSULATION DETAIL</p>	
<p>FND</p> <p>CABLE TRAY/LOOPER INSTALLATION DETAILS</p>	

FND

FND STANDARD DETAIL (SHEET-24)

PROJECT: SSCCL HEAD OFFICE BUILDING, KARACHI

DESIGNER: FARHAN NAWAZ & BEHZOORA (PVT) LTD

DATE: 1-10-2018

SCALE: AS SHOWN

REVISIONS:

NO.	DATE	DESCRIPTION
01	01-10-2018	ISSUED FOR TENDER
02	1-10-2018	ISSUED FOR TENDER
03	01-10-2018	REVISED

FOR: SUI SOUTHERN GAS COMPANY LIMITED

BY: SSCCL

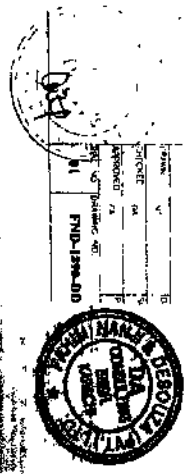

DWG. NO. 01 HVAC CONTROLS LIST OF DRAWING

DWG. NO.	DESCRIPTION
01	HVAC CONTROLS LIST OF DRAWING
02	HVAC CONTROLS LEGENDS & SYMBOLS
03	CONTROL SCHEMATIC FOR CENTRIFUGAL CHILLERS
04	CONTROL SCHEMATIC FOR CHILLED WATER AIR HANDLING UNIT WITH FRESH AIR

DWG. NO. 02 CONTROL SCHEMATIC FOR CENTRIFUGAL CHILLERS

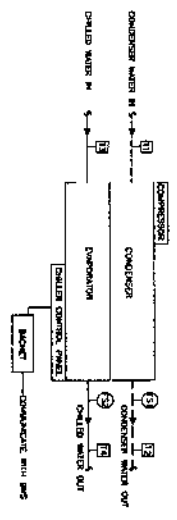

NOTES:
1. OUT SIDE AIR IS Bypassed as a single location from the cooling coil to the return air duct to the fan room.

QUANTITY - 02 UNITS

ITEM NO.	DESCRIPTION OF FIELD	LOCATION	AL TO NO.	CONTROL LOGIC
01	CONDENSER WATER M. 5-10	FAN ROOM	01	ON WHEN CONDENSER WATER PRESSURE IS LOW
02	CHILLED WATER M. 5-10	FAN ROOM	02	ON WHEN CHILLED WATER PRESSURE IS LOW
03	CONDENSER WATER M. 5-10	FAN ROOM	03	ON WHEN CONDENSER WATER PRESSURE IS LOW
04	CHILLED WATER M. 5-10	FAN ROOM	04	ON WHEN CHILLED WATER PRESSURE IS LOW
05	CONDENSER WATER M. 5-10	FAN ROOM	05	ON WHEN CONDENSER WATER PRESSURE IS LOW
06	CHILLED WATER M. 5-10	FAN ROOM	06	ON WHEN CHILLED WATER PRESSURE IS LOW
07	CONDENSER WATER M. 5-10	FAN ROOM	07	ON WHEN CONDENSER WATER PRESSURE IS LOW
08	CHILLED WATER M. 5-10	FAN ROOM	08	ON WHEN CHILLED WATER PRESSURE IS LOW
09	CONDENSER WATER M. 5-10	FAN ROOM	09	ON WHEN CONDENSER WATER PRESSURE IS LOW
10	CHILLED WATER M. 5-10	FAN ROOM	10	ON WHEN CHILLED WATER PRESSURE IS LOW
11	CONDENSER WATER M. 5-10	FAN ROOM	11	ON WHEN CONDENSER WATER PRESSURE IS LOW
12	CHILLED WATER M. 5-10	FAN ROOM	12	ON WHEN CHILLED WATER PRESSURE IS LOW

DWG. NO. 03 HVAC CONTROLS LEGENDS & SYMBOLS

SYMBOL	LEGEND
1	TEMPERATURE SENSOR
2	STARTER OF COMPRESSOR
3	FRESH AIR SWITCH
4	FRESH AIR
5	DIFFERENTIAL PRESSURE SWITCH
6	2-WAY MECHANICAL CONTROL VALVE

DWG. NO. 04 CONTROL SCHEMATIC FOR CHILLED WATER AIR HANDLING UNIT WITH FRESH AIR

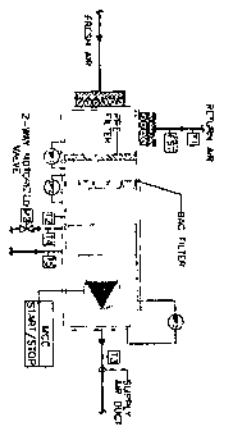

NOTES:
1. THIS UNIT IS CONTROLLED BY THE CHILLED WATER AIR HANDLING UNIT.

QUANTITY - 01 NO. HORIZONTAL AHU

ITEM NO.	DESCRIPTION OF FIELD	LOCATION	AL TO NO.	CONTROL LOGIC
01	TEMPERATURE SENSOR	FAN ROOM	01	ON WHEN TEMPERATURE IS HIGH
02	TEMPERATURE SENSOR	FAN ROOM	02	ON WHEN TEMPERATURE IS HIGH
03	TEMPERATURE SENSOR	FAN ROOM	03	ON WHEN TEMPERATURE IS HIGH
04	TEMPERATURE SENSOR	FAN ROOM	04	ON WHEN TEMPERATURE IS HIGH
05	TEMPERATURE SENSOR	FAN ROOM	05	ON WHEN TEMPERATURE IS HIGH
06	TEMPERATURE SENSOR	FAN ROOM	06	ON WHEN TEMPERATURE IS HIGH
07	TEMPERATURE SENSOR	FAN ROOM	07	ON WHEN TEMPERATURE IS HIGH
08	TEMPERATURE SENSOR	FAN ROOM	08	ON WHEN TEMPERATURE IS HIGH
09	TEMPERATURE SENSOR	FAN ROOM	09	ON WHEN TEMPERATURE IS HIGH
10	TEMPERATURE SENSOR	FAN ROOM	10	ON WHEN TEMPERATURE IS HIGH
11	TEMPERATURE SENSOR	FAN ROOM	11	ON WHEN TEMPERATURE IS HIGH
12	TEMPERATURE SENSOR	FAN ROOM	12	ON WHEN TEMPERATURE IS HIGH

DRAWING NO. 01
 PROJECT: BAS CONTROL SCHEMATIC
 PREPARED BY: [Name]
 CHECKED BY: [Name]
 DATE: [Date]
 FND-1890-DT

SU SOUTHERN GAS COMPANY LIMITED
 SSCCL HEAD OFFICE
 BUILDING, KARACHI

This drawing is the property of Fakhri Nami & Desouza Pvt. Ltd.
 and should not be used for any other project without the written
 consent of the company.



**SSGCL HEAD OFFICE BUILDING,
KARACHI**

**Observation Room Drawings by
SSGCL**

HVAC Works

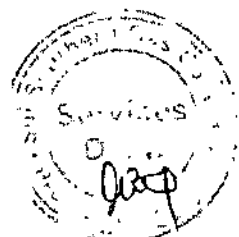

Fahim, Nanji & deSouza (Pvt.) Ltd.
Consulting Engineers





THERMAL STORAGE PUMP

CHEMICAL TANKS

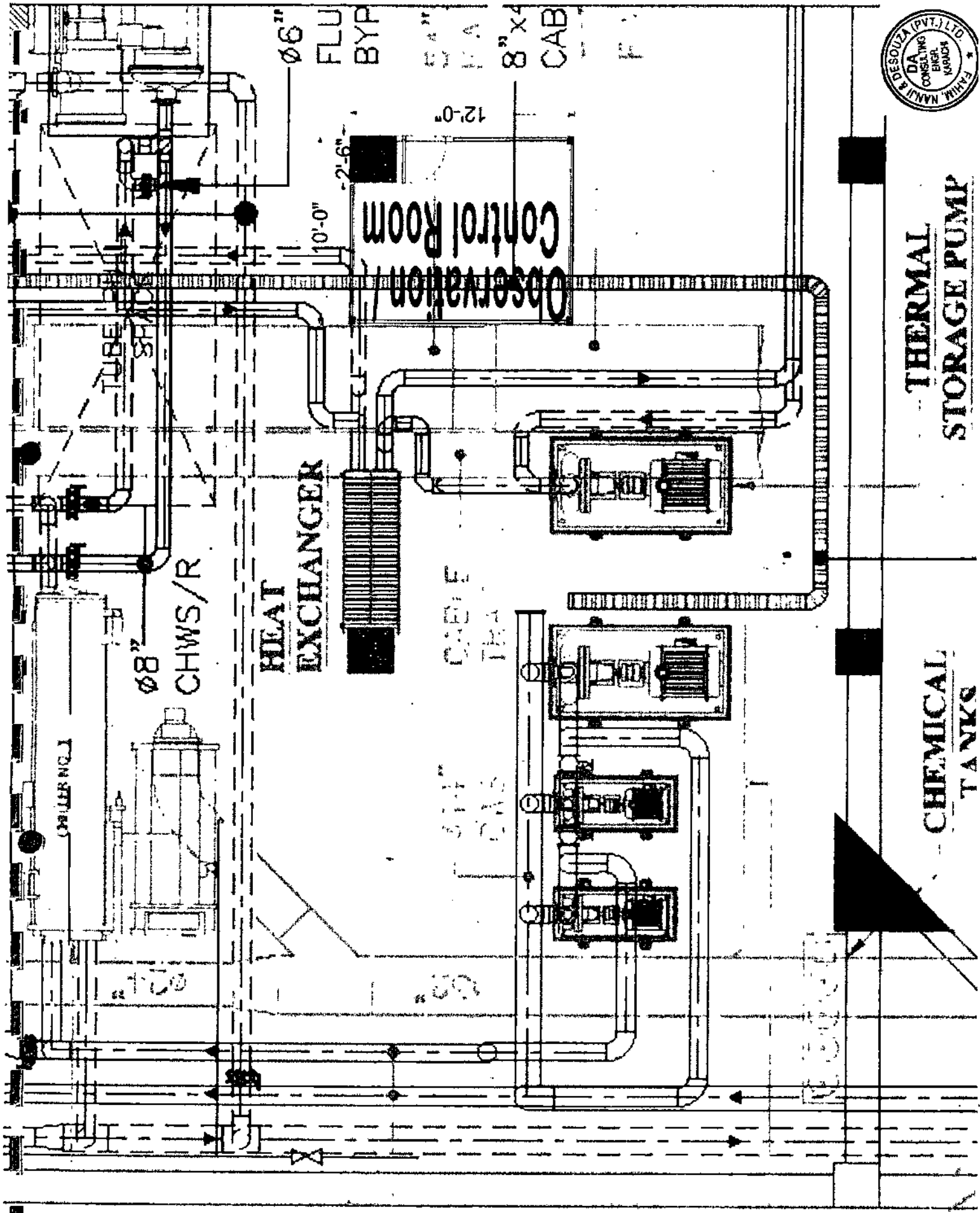

DIFFER

10"

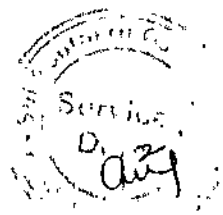

INSER PUMPS

Observation / Control Room

10'-0"

2'-6"

Pillar

12'-0"

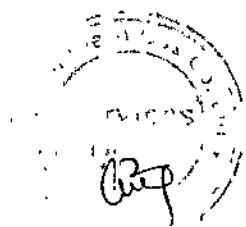

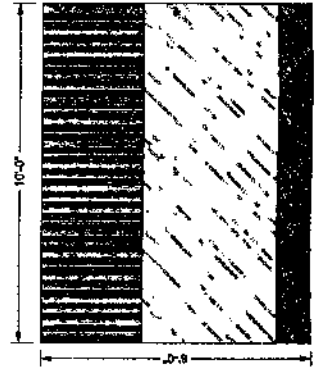
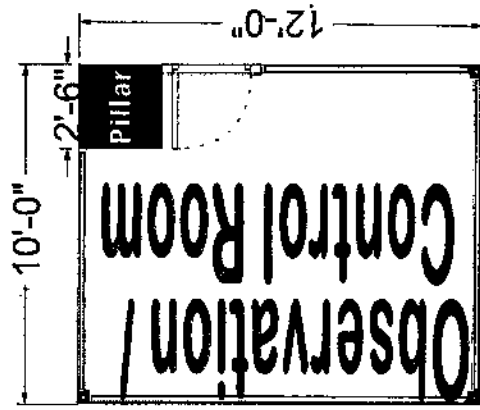
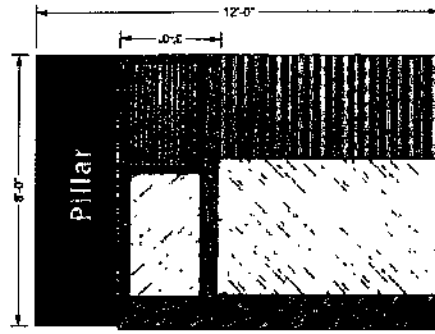

Elevation

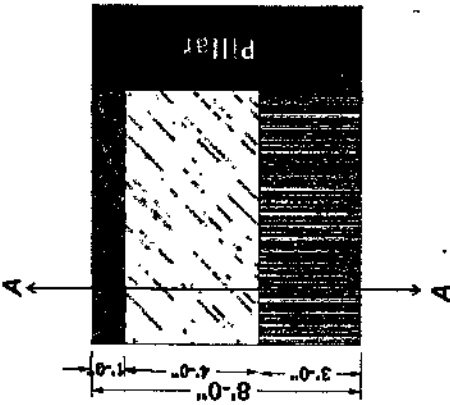

Section A-A

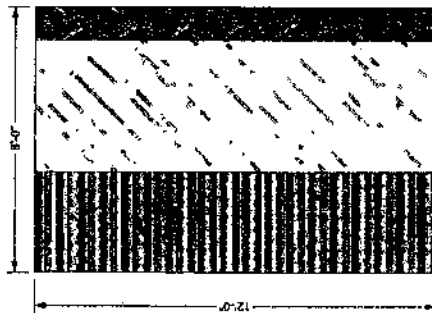

Handwritten signature and circular stamp.

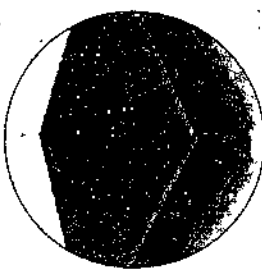
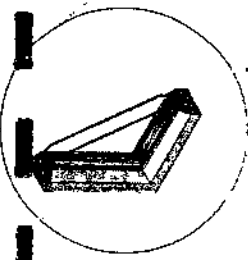



Elevation

Pillar

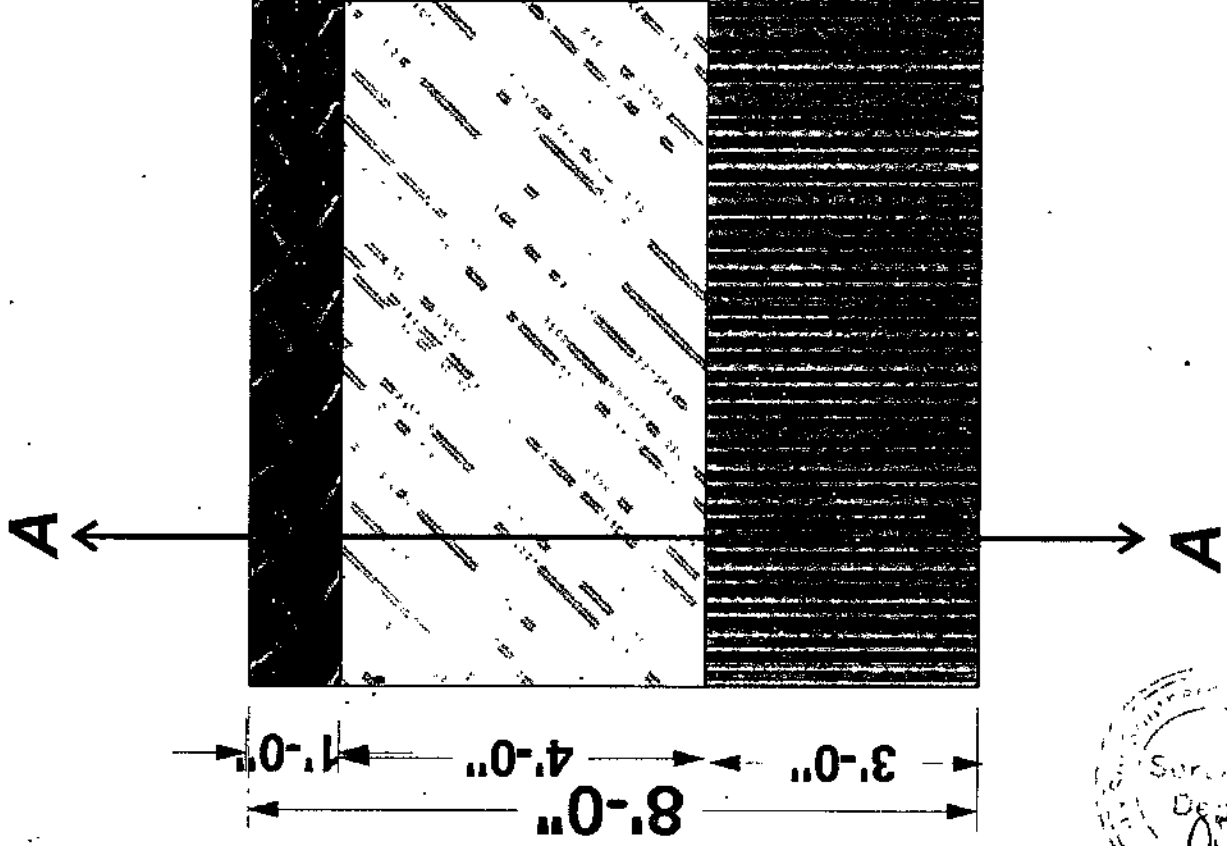

Section
A-A

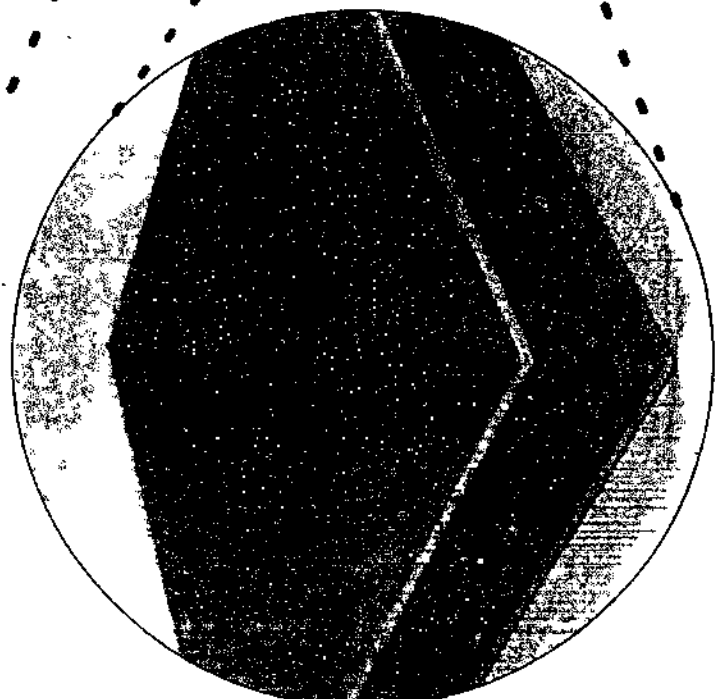
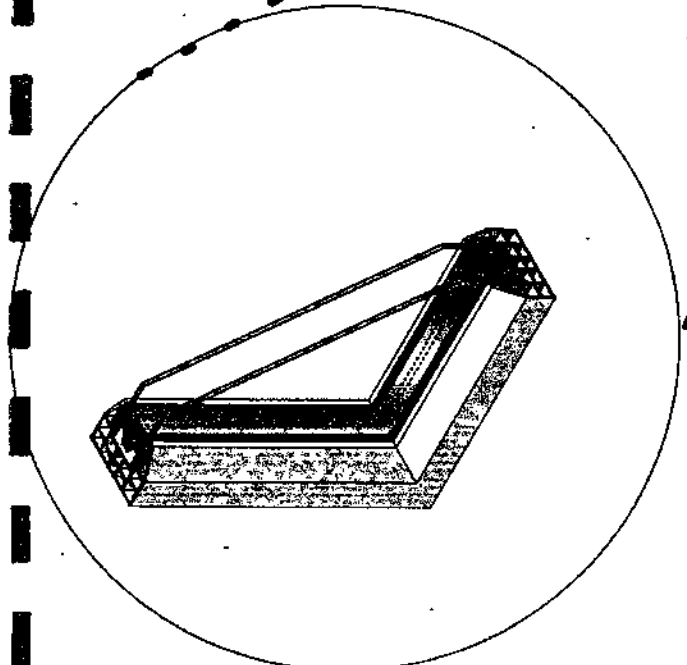

8'-0"



10'-0"

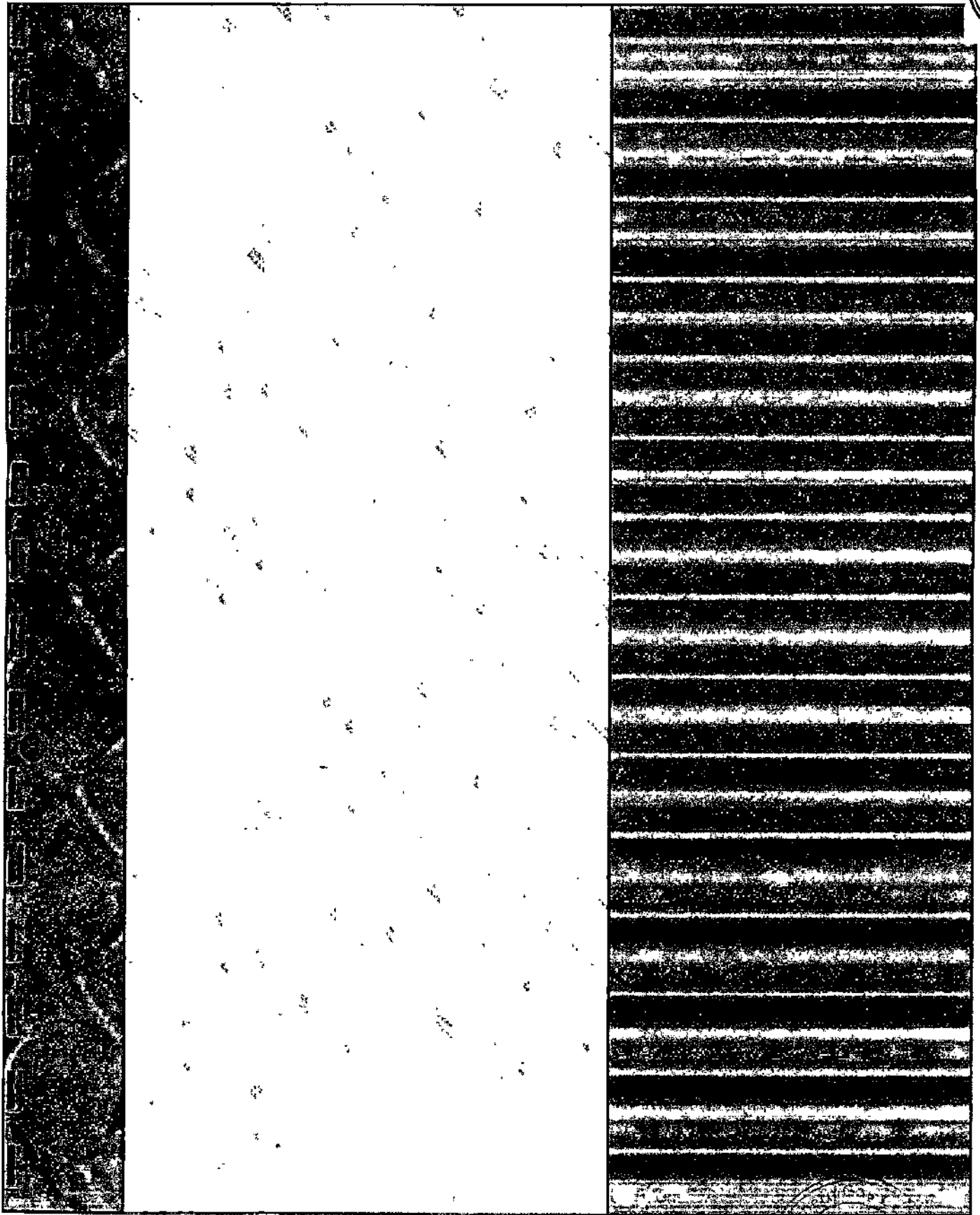

037



12'-0"

any

0-8



8'-0"

Pillar

3'-0"

2'-6"

12'-0"

Checked
Date
Asif

**Eligibility/ Evaluation Criteria Supporting Documents for HVAC Project at
SSGCL Head Office**

FORM I: COMPANY PROFILE*

Company Name: _____

Head Office Address: _____

Telephone No.: _____

Fax No. : _____

Office Address: _____

Telephone No. : _____

Fax No. : _____

Year Incorporated: _____

* All the information provided shall be supported with documentary evidence; otherwise no marks will be awarded.



**Eligibility/ Evaluation Criteria Supporting Documents for HVAC Project at
SSGCL Head Office**

FORM II: FINANCIAL SOUNDNESS*

Page ___ of Form II

Documentary evidence of Working Capital in last 5 years

- Firm's Certified/Audited Annual Account statements or report

* All the information provided shall be supported with documentary evidence; otherwise no marks will be awarded.



**Eligibility/ Evaluation Criteria Supporting Documents for HVAC Project at
SSGCL Head Office**

FORM III: EXPERIENCE RECORD*

Page ___ of Form III

Bidders need to specify the number of years establishing company in Pakistan including Nature of Company either of the following

1. Limited Company/Joint Venture
2. Partnership
3. Proprietorship

All the information provided shall be supported with documentary evidence; otherwise no marks will be awarded.

* Separate form should be submitted against each client

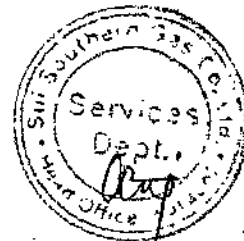

Eligibility/ Evaluation Criteria Supporting Documents for HVAC Project at
SSGCL Head Office

FORM IV: EXPERIENCE RECORD*

Page _____ of Form IV

**LIST OF COMPLETED PROJECTS OF SIMILAR NATURE AND COMPLEXITY
COMPLETED IN LAST 5 YEARS**

Name of Work:	_____
Scope of Work:	_____ _____
Value of Contract:	_____
Name of Client:	_____
Address of Client:	_____ _____ _____
Telephone of Client:	_____
Date of Award of Work:	_____
Start Date:	_____
Scheduled Completion Date:	_____
Actual Completion Date:	_____

* All the information provided shall be supported with documentary evidence; otherwise no marks will be awarded.

* Separate form should be submitted against each client



Eligibility/ Evaluation Criteria Supporting Documents for HVAC Project at
SSGCL Head Office

FORM V: EXPERIENCE RECORD*

Page _____ of Form V

**ELECTRICAL/MECHANICAL/ PIPING INTEGRATION PROJECTS OF SIMILAR
NATURE AND COMPLEXITY IN HAND**

Name of Work: _____

Scope of Work: _____

Value of Contract: _____

Name of Client: _____

Address of Client: _____

Telephone of Client: _____

Date of Award of Work: _____

Start Date: _____

Scheduled Completion Date: _____

Actual Completion Date: _____

* All the information provided shall be supported with documentary evidence; otherwise no marks will be awarded.

* Separate form should be submitted against each client

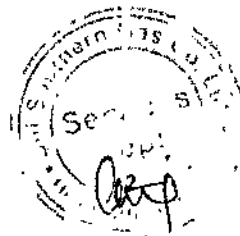

Eligibility/ Evaluation Criteria Supporting Documents for HVAC Project at
SSGCL Head Office

FORM VI: PERSONAL CAPABILITIES*

Page _____ of Form VI

HVAC OEM certified/ authorized local resource for installation, commissioning, operation, & Maintenance services (Any reputable chiller manufactures)

-
- * All the information provided shall be supported with documentary evidence; otherwise no marks will be awarded.
 - * Separate form should be submitted against each client

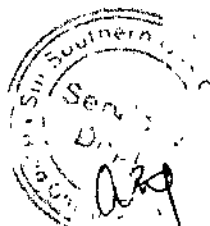

**Eligibility/ Evaluation Criteria Supporting Documents for HVAC Project at
SSGCL Head Office**

FORM VII: PERSONAL CAPABILITIES*

Page _____ of Form VII

ENROLLED ENGINEERS REGISTERED WITH PEC

- 1. CV of Project team lead
- 2. CV of Mechanical Engineer
- 3. CV of Elect/ Electronics

CURRICULUM VITAE

- 1. Name of Expert: *[Insert full name]* _____
- 2. Date of Birth: _____ Citizenship Evidence: _____
- 3. Complete personal contact details: *[Include complete address and telephone number/ email address]* _____
- 4. Education: *[Indicate college/university and other specialized education of expert, giving names of institutions, degrees obtained, and dates of obtainment]* _____
- 5. Membership in Professional Associations: _____
- 6. Other Training: *[Indicate significant training since degrees under "6. Education" were obtained]* _____
- 7. Countries of Work Experience: *[List countries where expert has worked in the last 15 years]* _____
- 8. Languages: *[For each language indicate proficiency]*

Language	Level of Proficiency (mother tongue, excellent, good, fair, poor)		
	Speaking	Reading	Writing

- 9. Employment Record: *[Starting with present position, list in reverse order every employment held by expert since graduation, giving for each employment (see format here below): dates of employment, name of employing organization, positions held.]*

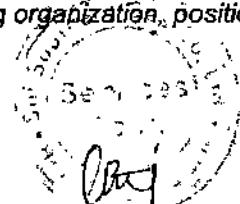



**Eligibility/ Evaluation Criteria Supporting Documents for HVAC Project at
SSGCL Head Office**

FORM VIII: PERSONAL CAPABILITIES*

Page _____ of Form VIII

DIPLOMA ENGINEERS IN EMPLOYMENT OF THE FIRM

1. CV of HVAC Supervisor
3. CV of Elect/ Electronics supervisor

* All the information provided shall be supported with documentary evidence; otherwise no marks will be awarded.

* Separate form should be submitted against each client

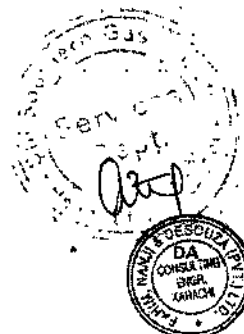

SUI SOUTHERN GAS COMPANY LIMITED

UNDERTAKING OF COMPLIANCE WITH INTEGRATED MANAGEMENT SYSTEM (IMS) MANUAL AND BLACKLISTING MECHANISM

I, _____ [Supplier's Authorized Representative
Full Name], of _____ [Supplier Company Name], with
principal office located _____ at
_____ [Full
Address], do hereby solemnly affirm and declare as follows:

1. That I am the duly authorized representative of _____ [Supplier Company Name], and have the legal authority to make this declaration on behalf of the company.
2. That I confirm having accessed, read, and fully understood the **Integrated Management System (IMS) Manual** provided by Sui Southern Gas Company Limited (SSGC), available at the official website:
<https://www.ssgc.com.pk/web/wp-content/uploads/2025/06/IMS-Manual-1-1.pdf>
3. That _____ [Supplier Company Name] agrees to comply fully with all the policies, procedures, and responsibilities outlined in the IMS Manual, and will ensure that all relevant employees, contractors, and agents are made aware of and comply with the same.
4. That _____ [Supplier Company Name] acknowledges that failure to comply with the IMS Manual may result in corrective action, including but not limited to financial penalties as per SSGC policy and suspension or termination of business with Sui Southern Gas Company Limited (SSGC).
5. That the bidder has also read, understood, and accepted the **Blacklisting Mechanism of Sui Southern Gas Company Limited (SSGC)**, available at:
https://www.ssgc.com.pk/web/wp-content/uploads/2024/09/blacklisting_mechanism_2024.pdf
6. Any type of violation of the tender terms and non-performance will result in the enforcement of the Blacklisting Mechanism, which will be dealt with in accordance with the Blacklisting Rules/Mechanism.
7. This affidavit is made in good faith and for the purpose of affirming our commitment to health, safety, environmental standards, and compliance with the **Integrated Management System (IMS) Manual** and the **Blacklisting Mechanism** of Sui Southern Gas Company Limited (SSGC), as well as all other applicable policies and procedures of SSGC.

Signed at _____ [City] on this _____ day of _____, 20__.

Signature: _____
Name: _____
Designation: _____
Company Name: _____
Contact Details: _____

(Company Stamp / Seal Mandatory)

Witnessed by:

Signature of Witness: _____
Name of Witness: _____
Date: _____

Signature of Witness: _____
Name of Witness: _____
Date: _____

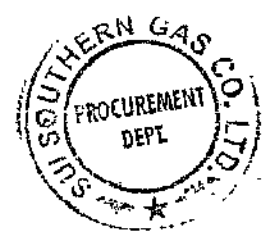

SSTW-05

Ref No _____

Dated _____

M/s _____

SNTN _____

Address _____

NOTICE UNDER RULE 3(1) OF THE SINDH SALES TAX SPECIAL PROCEDURE (WITHHOLDING) RULES, 2011.

Dear Sir,

Kindly note that we are a withholding agent under the Sindh Sales Tax Special Procedure (Withholding) Rules, 2011, and that we shall withhold and deduct the prescribed amounts of Sindh sales tax against your tax invoices in relation to the services provided or rendered by you to us. We hold NTN/FTN

2. We undertake to deposit the withheld/deducted amounts of Sindh sales tax in the Sindh Government's head of account "B-02384" against a SRB-prescribed PSID/Challan (SST-04 or SSTW-04) in the manner prescribed under the aforesaid Sindh Sales Tax Special Procedure (Withholding) Rules, 2011, and we shall provide you a certificate of deduction-cum-deposit in terms of rule 3(9) thereof.

Signature _____

Name _____

CNIC _____

Designation _____

Date _____

Official seal _____

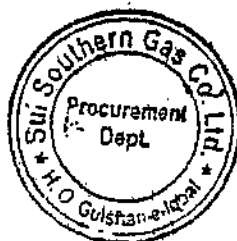

Form of Bid-Securing Declaration

[The Bidder shall fill in this Form in accordance with the instructions indicated.]

Date: [date (as day, month and year)]

Alternative No.: [insert identification No if this is a Bid for an alternative]
No.: [number of Bidding process]

To: [complete name of Procuring Agency]

We, the undersigned, declare that

We understand that, according to your conditions, Bids must be supported by a Bid-Securing Declaration.

We accept that we will be blacklisted and henceforth cross-debarred for participating in respective category of public procurement proceedings for a period of (not more than) six months, if fail to abide with a bid securing declaration, however without indulging in corrupt and fraudulent practices, if we are in breach of our obligation(s) under the Bid-conditions, because we:

(a) have withdrawn our Bid during the period of Bid validity specified in the Letter of Bid; or

(b) having been notified of the acceptance of our Bid by the Procuring Agency during the period of Bid validity, (i) fail or refuse to sign the Contract; or (ii) fail or refuse to furnish the Performance Security (or guarantee), if required, in accordance with the ITB.

We understand this Bid Securing Declaration shall expire if we are not the successful Bidder, upon the earlier of (i) our receipt of your notification to us of the name of the successful Bidder; or (ii) twenty-eight days after the expiration of our Bid.

Name of the Bidder: _____

Name of the person duly authorized to sign the Bid on behalf of the Bidder: _____

Title of the person signing the Bid: _____

Signature of the person named above: _____

Date signed: _____

* In the case of the Bid submitted by joint venture specify the name of the Joint Venture as Bidder

* Person signing the Bid shall have the power of attorney given by the Bidder attached to the Bid

[Note: in case of a Joint Venture, the Bid-Securing Declaration must be in the name of all members to the Joint Venture that submits the Bid.]

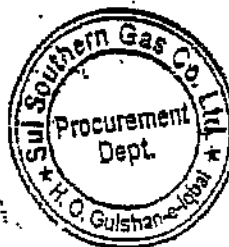

Supplier code: _____

FORM-X

Bank account details form for all Beneficiaries

(Mandatory requirement for Digital Online Banking)

As per FBR Regulations ref # C.No.4 (24) IT-Budget/2021-142150-R dated 23rd Sept'2021 to make the payment online w.e.f. 01-11-2021. All beneficiaries are required to fill in the below details, which is mandatory:

Name of Firm: _____

Address of Firm: _____

CNIC #: _____

NTN #: _____

Bank Name: _____

Bank A/C Title name: _____

Branch code: _____

Bank A/c #: _____ (16 Digits)

Bank IBAN #: _____ (24 Digits)

Information already submitted.

Note: Please be attached copy of Cheque / Account Maintenance Certificate.(Mandatory)

Authorized Sign & Stamp

Date: _____

Note: All payments transactions will be made on above mentioned Account details. This is only a one time information to be provided by the all beneficiaries. Incase if the above detail has already submitted, please tick the box above "Information already submitted" and also ensure Form-X is duly signed & stamped.

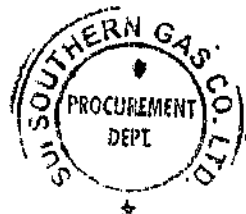

SUI SOUTHERN GAS COMPANY LIMITED

UNDERTAKING OF COMPLIANCE WITH INTEGRATED MANAGEMENT SYSTEM (IMS) MANUAL AND BLACKLISTING MECHANISM

I, _____ [Supplier's Authorized Representative Full Name], of _____ [Supplier Company Name], with principal _____ office _____ located _____ at _____ [Full Address], do hereby solemnly affirm and declare as follows:

1. That I am the duly authorized representative of _____ [Supplier Company Name], and have the legal authority to make this declaration on behalf of the company.
2. That I confirm having accessed, read, and fully understood the **Integrated Management System (IMS) Manual** provided by Sui Southern Gas Company Limited (SSGC), available at the official website:
<https://www.ssgc.com.pk/web/wp-content/uploads/2025/06/IMS-Mannual-1-1.pdf>
3. That _____ [Supplier Company Name] agrees to comply fully with all the policies, procedures, and responsibilities outlined in the IMS Manual, and will ensure that all relevant employees, contractors, and agents are made aware of and comply with the same.
4. That _____ [Supplier Company Name] acknowledges that failure to comply with the IMS Manual may result in corrective action, including but not limited to financial penalties as per SSGC policy and suspension or termination of business with Sui Southern Gas Company Limited (SSGC).
5. That the bidder has also read, understood, and accepted the **Blacklisting Mechanism of Sui Southern Gas Company Limited (SSGC)**, available at:
https://www.ssgc.com.pk/web/wp-content/uploads/2024/09/blacklisting_mechanism_2024.pdf
6. Any type of violation of the tender terms and non-performance will result in the enforcement of the Blacklisting Mechanism, which will be dealt with in accordance with the Blacklisting Rules/Mechanism.
7. This affidavit is made in good faith and for the purpose of affirming our commitment to health, safety, environmental standards, and compliance with the **Integrated Management System (IMS) Manual** and the **Blacklisting Mechanism** of Sui Southern Gas Company Limited (SSGC), as well as all other applicable policies and procedures of SSGC.

Signed at _____ [City] on this _____ day of _____, 20 .

Signature: _____
Name: _____
Designation: _____
Company Name: _____
Contact Details: _____

(Company Stamp / Seal Mandatory)

Witnessed by:

Signature of Witness: _____
Name of Witness: _____
Date: _____

Signature of Witness: _____
Name of Witness: _____
Date: _____





سوی سدرن گیس کمپنی لمیٹڈ
پروکیورمنٹ ٹینڈر منٹ

تمام ٹھیکیداروں کے لئے معیاری ایڈوائزرز
خدمات کی ادائیگی پر سندھ سیلز ٹیکس
(۱ جولائی ۲۰۲۴ سے نافذ العمل)

س منظر

مطلع کیا جائے کہ:
1. فروری 2024 تک، SSGC نے سندھ میں فراہم کی جانے والی خدمات کے لیے وینڈرز کی انوائس ویلیو سے سندھ سیلز ٹیکس کی رقم کا 20% کاٹ لیا ہے اور اسے سندھ ریونیو بورڈ کے پاس جمع کرایا ہے، جبکہ وینڈرز بقیہ 80% خود جمع کراتے ہیں۔

2. مارچ 2024 سے جون 2024 تک، SSGC نے سندھ میں فراہم کی جانے والی خدمات کے لیے وینڈرز کی انوائس ویلیو سے سندھ سیلز ٹیکس کی رقم کا 80% کاٹ لیا ہے اور اسے سندھ ریونیو بورڈ کے پاس جمع کرایا ہے، جبکہ بقیہ 20% وینڈرز خود جمع کراتے ہیں۔

قانون میں ترمیم

سندھ ریونیو بورڈ (SRB) نے ود ہولڈنگ رولز میں ترمیم کی ہے جس کے تحت SSGC کو انوائس ویلیو سے سیلز ٹیکس کی رقم کا 20% کٹوتی کرنا ہوگی۔

سندھ سیلز ٹیکس ود ہولڈنگ کا نظر ثانی شدہ طریقہ کار

مندرجہ بالا ترمیم کے نفاذ کو یقینی بنانے کے لیے، 01 جولائی 2024 سے درج ذیل عمل کو نافذ کیا جا رہا ہے:

1) 80% سیلز ٹیکس صرف 'ماضی' انوائسز پر کٹوتی جاری رہے گی (جہاں وینڈر نے پہلے ہی سرکاری خزانے میں 20% سیلز ٹیکس جمع کرایا ہے اس کا ثبوت فراہم کرتا ہے)۔

2) 20% سیلز ٹیکس موجودہ اور مستقبل کے انوائسز پر کاٹا جائے گا (جبکہ 80% وینڈر براہ راست SRB کے ساتھ جمع کرائے گا)

یہ واضح رہے کہ صرف سندھ ود ہولڈنگ رولز وائٹ میں ترمیم کی گئی ہے دیگر رولز (انکم ٹیکس ود ہولڈنگ بلوچستان سیلز ٹیکس ود ہولڈنگ وغیرہ) میں کوئی تبدیلی نہیں کی گئی ہے۔



**Sui Southern Gas
Company Limited**

Procurement Department

Standard Advisory to all Bidders

SUB: Sindh Sales Tax Withholding On Services Payment

(Effective from 1 July 2024)

Dear Sir,

Background

Please be informed that:

1. Uptil February 2024, SSGC deducted 20% of Sindh Sales Tax amount from Invoice value payable to a Vendor for services rendered in Sindh & deposit the same with Sindh Revenue Board, while remaining 80% is deposited by the Vendor themselves.
2. From March 2024 – June 2024, SSGC deducted 80% of Sindh Sales Tax amount from Invoice value payable to a Vendor for services rendered in Sindh & deposit the same with Sindh Revenue Board, while remaining 20% is deposited by the Vendor themselves

Amendment in Law

Sindh Revenue Board (SRB) has amended Withholding Rules thereby requiring SSGC to deduct 20% of sales tax amount from Invoice Value.

Revised Procedure for Sindh Sales Tax Withholding

In order to ensure implementation of above amendment, following process is being implemented 01. July 2024:

- 1) 80% Sales Tax to continue to be withheld on 'Past' Invoices only (where Vendor has already deposited 20% Sales Tax in Government treasury provides evidence thereof).
- 2) 20% Sales Tax will be deducted on Current and future invoices (while 80% will be deposited by vendor directly with SRB)

It is needless to mention that only Sindh Withholding Rules have been amended while there is no change in other Rules (income tax withholding Balochistan Sales Tax withholding; etc.)

ANNEXURE: I

Declaration of Ultimate Beneficial Owners Information for Public Procurement Contracts.

1. Name
2. Father's Name/Spouse's Name
3. CNIC / NICOP/Passport No.
4. Nationality
5. Residential address
6. Email address
7. Date on which shareholding, control or interest acquired in the business.
8. In case of indirect shareholding, control or interest being exercised through intermediary companies, entities or other legal persons or legal arrangements in the chain of ownership or control, following additional particulars to be provided:

1	2	3	4	5	6	7	8	9	10
Name	Legal form (Company/Limited Liability Partnership /Association of Persons/Single Member Company/Partnership Firm/Trusted/Any other Individual, Body Corporate (to be Specified)	Date of Incorporation / Registration	Name of Registering Authority	Business Address	Country	Email Address	Percentage of shareholding control or interest of BO in the Legal Person or Legal Arrangement	Percentage of shareholding, Control or Interest of Legal Person or Legal Arrangement in the Company	Identity of Natural Person who Ultimately owns or Controls the Legal Person or Arrangement

9. Information about the Board of Directors (details shall be provided regarding number of shares in the capital of the company as set opposite respective names).



Part II

THE GAZETTE OF PAKISTAN, EXTRA, MAY 14, 2022 I

1	2	3	4	5	6	7	8
Name and surname (in block Letter's)	CNIC no (in case of foreigner Passport No)	Father's / Husband's Name in Full	Current Nationality	Any other Nationality (ies)	Occupation	Residential address in full of the registered / principle office address for a subscribers other than natural Person	Numbers of shares taken by cash subscribers (in figures and words)
Total numbers of shares taken (in figures and words)							

10. Any other information incidental to or relevant to beneficial owners).

Name and signature
(Person authorized to issue notice on behalf of the company)

